

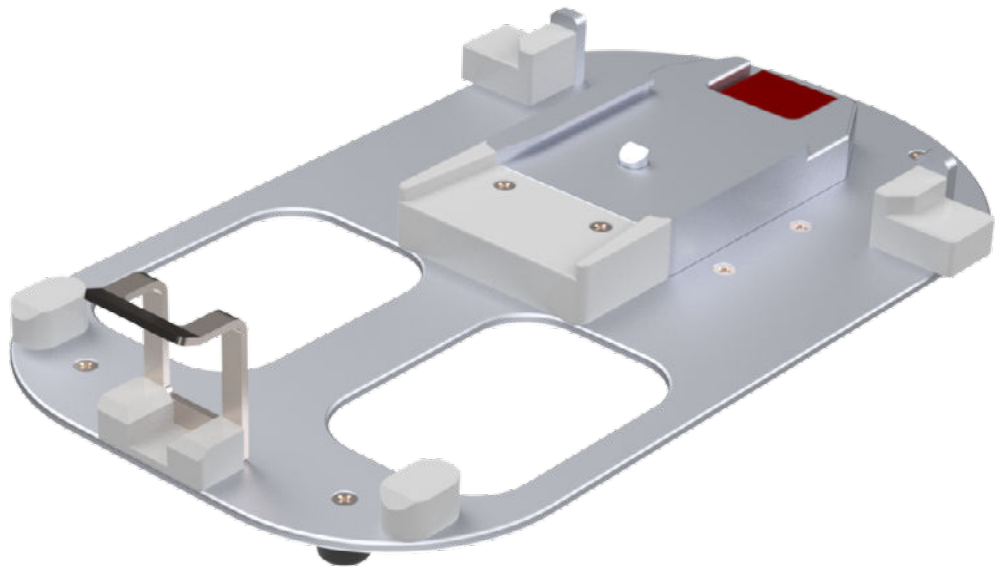

**TECHNIMOUNT**  
EMS™

# **BRACKET PRO SERIE® 112**

## USER GUIDE



# COPYRIGHT

---

Copyright 2022 Technimount E.M.S. Holding Inc. (Technimount), an affiliated company of Technologies CGC Inc. All Rights Reserved. No part of this publication may be reproduced, transmitted, transcribed, stored in a retrieval system, or translated into any language in any form or by any means without the written permission of Technimount or its affiliate companies.

**Trademark Attributions:**

Bracket Pro Serie®, Technimount EMS™ are registered trademarks of Technologies CGC Inc.

Cardiohelp® is a registered trademark of Maquet Cardiohelp Maquet Cardiopulmonary GmbH.

In order to ensure continuous improvements to our products and services, we invite you to communicate your comments to our Customer Service Department at [customerservice@technimount.com](mailto:customerservice@technimount.com).

**NOTE:**

Technimount EMS Holdinc Inc. does not have a commercial relationship with Getinge Cardiohelp Medical Device.

# CONTACT INFORMATION

---

## OFFICE ADDRESS

TECHMOUNT E.M.S. HOLDING INC.  
3770 Jean Marchand Street, Suite 100-C  
Quebec (QC) G2C 1Y6  
Canada

[info@technimount.com](mailto:info@technimount.com)

[www.technimount.com](http://www.technimount.com)

T + 1 581.700.6613

TF + 1 888.639.2758

## NOTE:

For any issues with your Technimount product, its components, or for any technical questions during the installation or maintenance processes, please send an email to [techsupport@technimount.com](mailto:techsupport@technimount.com).

Please have the serial number of your Technimount product available (as shown in the figure below) when calling Technimount Technical Support. Include the serial number in all written communications.

## SERIAL NUMBER LOCATION

THE SERIAL NUMBER IS  
WRITTEN UNDER THE BRACKET  
AS SHOWN IN THIS IMAGE

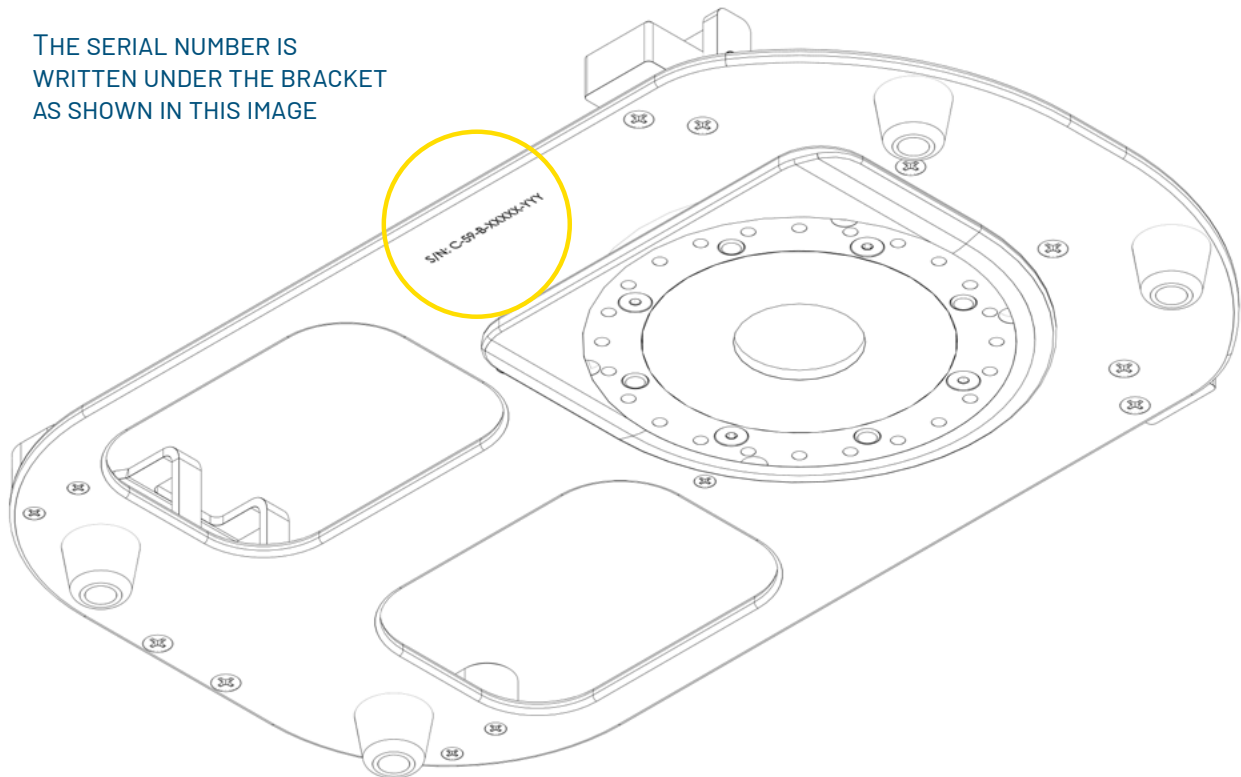

[Return to Table of Contents](#)

# TABLE OF CONTENTS

---

|  |           |
|--|-----------|
| <b>COPYRIGHT .....</b>                               | <b>2</b>  |
| <b>CONTACT INFORMATION.....</b>                      | <b>3</b>  |
| SYMBOLS AND DEFINITIONS .....                        | 6         |
| WARNING/CAUTION/NOTE .....                           | 7         |
| PRODUCT ILLUSTRATION.....                            | 8         |
| <i>BRACKET PRO SERIE 112</i> .....                   | 8         |
| <i>FRONT VIEW</i> .....                              | 8         |
| <i>BACK VIEW</i> .....                               | 9         |
| <b>INTRODUCTION .....</b>                            | <b>10</b> |
| PURPOSE OF THE DOCUMENT .....                        | 10        |
| PRODUCT DESCRIPTION .....                            | 10        |
| INTENDED USE OF THE PRODUCT .....                    | 10        |
| TECHNICAL SPECIFICATIONS.....                        | 11        |
| <b>SUMMARY OF SAFETY PRECAUTIONS .....</b>           | <b>12</b> |
| WARNING/CAUTION/NOTE .....                           | 12        |
| <b>NOTICE .....</b>                                  | <b>14</b> |
| <b>INSTALLATION GUIDE .....</b>                      | <b>15</b> |
| REMOVING THE PACKAGING FOR INSTALLATION.....         | 15        |
| TOOLS REQUIRED FOR INSTALLATION.....                 | 15        |
| LIST OF MATERIAL .....                               | 15        |
| INSTALLATION OF THE CARDIOHELP INTO THE BRACKET..... | 16        |
| <b>INSTALLATION GUIDE .....</b>                      | <b>17</b> |
| REMOVING THE CARDIOHELP FROM THE BRACKET .....       | 17        |
| <b>OPERATION GUIDE .....</b>                         | <b>18</b> |
| <b>MAINTENANCE GUIDE.....</b>                        | <b>20</b> |
| CLEANING .....                                       | 20        |
| <i>CLEANING PROCESS</i> .....                        | 20        |
| <i>REMOVAL OF IODINE COMPOUNDS</i> .....             | 21        |
| PREVENTIVE MAINTENANCE .....                         | 21        |
| INSPECTION PROCESS AND SCHEDULE.....                 | 22        |
| <i>MAINTENANCE PROGRAM</i> .....                     | 22        |
| INSPECTION AND MAINTENANCE RECORD.....               | 23        |
| TRAINING RECORD.....                                 | 24        |
| REPLACEMENT PARTS.....                               | 25        |
| <b>WARRANTY .....</b>                                | <b>26</b> |
| WARRANTY POLICY.....                                 | 26        |
| LIMITED RESPONSIBILITY AND WARRANTY.....             | 26        |
| INTERNATIONAL WARRANTY CLAUSE .....                  | 26        |
| <b>RETURN POLICY .....</b>                           | <b>27</b> |
| RETURN POLICY.....                                   | 27        |
| <i>PRIOR TO 30 DAYS</i> .....                        | 27        |
| <i>PRIOR 45 DAYS</i> .....                           | 27        |

# TABLE OF CONTENTS



---

|                                      |    |
|--------------------------------------|----|
| <i>PRIOR 60 DAYS</i> .....           | 27 |
| RETURN AUTHORIZATION .....           | 27 |
| DAMAGED MERCHANDISE.....             | 28 |
| CLAIM PROCESS .....                  | 28 |
| <i>REQUIRED INFORMATION</i> .....    | 28 |
| <i>FINDINGS AND CONCLUSION</i> ..... | 28 |
| QUESTIONS ABOUT OUR POLICY .....     | 28 |

# INTRODUCTION

---

## SYMBOLS AND DEFINITIONS



| <u>SYMBOL</u>   | <u>DESCRIPTION</u>   |
|---|--|
|  | Warning and Caution, special attention is required. Consult accompanying documents |
|  | Safe working load symbol and Load balance symbol                                   |

# INTRODUCTION

---

## WARNING/CAUTION/NOTE

The word warning, caution, or note carry special meaning and should be carefully reviewed.

| <u>SYMBOL</u>   | <u>DESCRIPTION</u>   |
|---|--|
|  | <p><b>WARNING</b></p> <p>Alerts the reader about a situation which, if not avoided, could result in death or serious injury. It may also describe potential serious adverse reactions and safety hazards.</p>  |
|  | <p><b>CAUTION</b></p> <p>Alerts the reader of a potentially hazardous situation, which, if not avoided, may result in minor or moderate injury to the user or patient or damage to the equipment or other property. This includes special care necessary for the safe and effective use of the device to avoid damage that may occur as a result of use or misuse.</p> |
| <b>NOTE</b>   | <p>Provides special information about the product.</p>   |

# INTRODUCTION

---

## PRODUCT ILLUSTRATION

[BRACKET PRO SERIE 112](#)

[Front View](#)

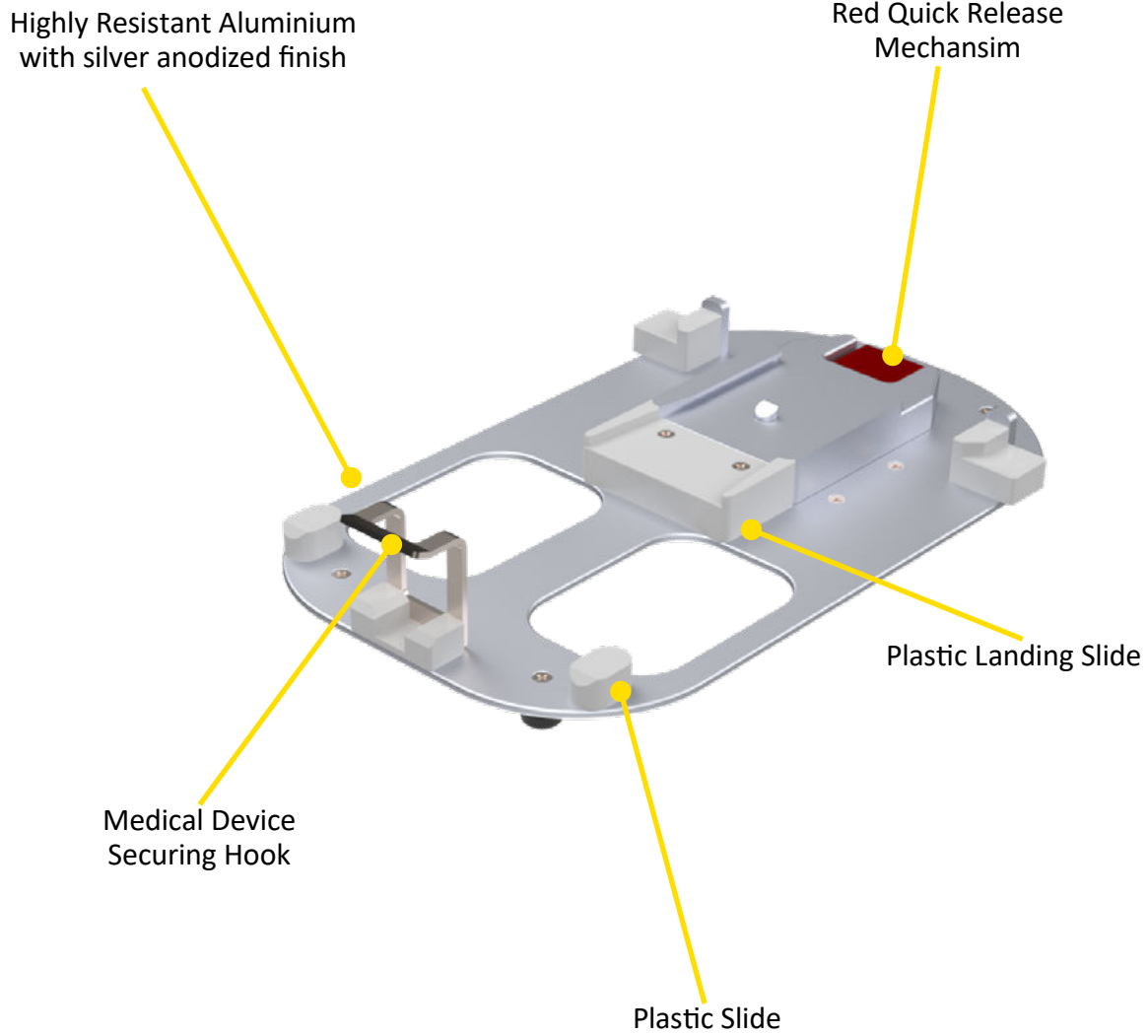

# INTRODUCTION

---

## PRODUCT ILLUSTRATION (CONTINUED)

[BRACKET PRO SERIE 112](#)

[Back View](#)

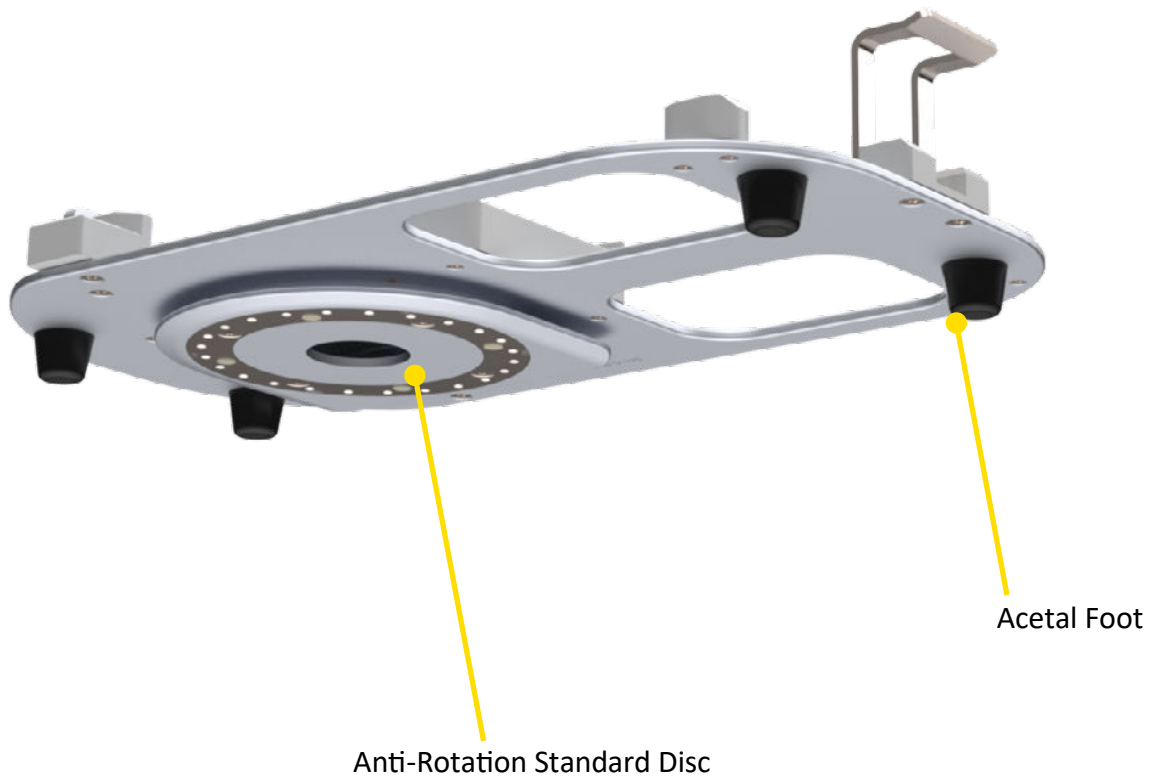

# INTRODUCTION

---

## PURPOSE OF THE DOCUMENT

This user guide is designed to assist you with the installation, operation, and maintenance of the Bracket Pro Serie 112 for the Getinge Cardiohelp System device.

## PRODUCT DESCRIPTION

The Bracket Pro Serie 112 is a mounting system for the Cardiohelp System. It can be used in different applications such as on a surface, floor, cot/stretcher. It is designed to securely support and transport the Getinge Cardiohelp ECMO device in pre-hospital environments and it can fit into any ground ambulance configurations. When used in emergency vehicles with a cot/ stretcher, the Bracket Pro Serie 112 can be positioned on Technimount's Standard Base and on the Xtension Pro™ Assistant - CCT. These solutions provide a higher flexibility for different EMS/CCT protocols and applications. This mounting system is compatible with all of Technimount's products.

## INTENDED USE OF THE PRODUCT

The Bracket Pro Serie 112 is a mounting solution to securely transport the Cardiohelp System™ from Getinge during inter-hospital transfers. It is designed to be installed on the equipment as described in this user guide. The Bracket Pro Serie 112 is for crews who have received the appropriate training necessary to operate the equipment in the field according to its intended use as outlined in this user guide. Please read this user guide thoroughly before using this equipment. To ensure the safe operation of this equipment, it is highly recommended to train staff prior to use.

# INTRODUCTION

---

## TECHNICAL SPECIFICATIONS

|  |   |
|--|---|
| <b>Product Name</b>                            | Bracket Pro Serie® 112  |
| <b>Product Description</b>                     | Mounting System for the Getinge Cardiohelp System from ECMO device for emergency and critical care transport  |
| <b>Compatibility of Medical Device</b>         | Getinge® Cardiohelp System™   |
| <b>Environment of Usage</b>                    | EMS/CCT (Ground) – Hospital/Clinic  |
| <b>Product Section Material</b>                | <ul style="list-style-type: none"><li>• Main Assembly: Aluminum 6061-T6 and Acetal</li><li>• Anti-Rotation Standard Disc: Aluminum 6061-T6</li></ul>  |
| <b>Product Finish</b>                          | <ul style="list-style-type: none"><li>• Main Assembly: Silver anodized finish</li><li>• Anti-Rotation Standard Disc: Silver anodized finish</li></ul>   |
| <b>Environmental Regulations</b>               | RoHS 3 compliant  |
| <b>Temperature of Usage</b>                    | -31° F to 113° F (- 35° C to 45° C)   |
| <b>Certification</b>                           | Tested in compliance with: <ul style="list-style-type: none"><li>• SAE J3043</li><li>• AMD-028</li></ul>  |
| <b>Installation</b>                            | Device retained on main assembly with Red Quick Release Mechanism   |
| <b>Attachment Options</b>                      | Anti-Rotation Standard Disc   |
| <b>Transportation System Compatibility</b>     | Compatible with Technimount's: <ul style="list-style-type: none"><li>• Standard Base</li><li>• Extended Base</li></ul>  |
| <b>Features</b>                                | <ul style="list-style-type: none"><li>• Access to all medical device monitors, connectors and accessories</li><li>• Red Quick Release Mechanism for easy installation and removal of medical device</li></ul> |
| <b>Physical Overall Dimensions (L x D x H)</b> | 16.52 in x 9.67 in x 3.48 in (41.96 cm x 24.56 cm x 8.84 cm)  |
| <b>Weight</b>                                  | 4.74 lb (2.15 kg)   |
| <b>Safe Working Load</b>                       | 32 lb (14.5 kg)   |
| <b>Part Number</b>                             | 2410-10-MQCH  |
| <b>Other Models and Configuration Options</b>  | Contact Technimount EMS for more information or for other options at <a href="mailto:customerservice@technimount.com">customerservice@technimount.com</a>   |

Note: Product and medical equipment manufacturers names are Trademarks™ or Registered Trademarks® of their respective holders. Technimount does not have a commercial relationship with these medical equipment manufacturers.

[Return to Table of Contents](#)

# SUMMARY OF SAFETY PRECAUTIONS

---

## WARNING/CAUTION/NOTE

Carefully read and strictly follow all Warnings and Cautions listed in this user guide. Servicing and maintenance should only be done by qualified personnel.

---

### WARNING

---

- ✓ Read and follow the medical device user guide and recommendations for proper usage of the medical device with Technimount product. Failure to comply could result in improper medical device performance and injury to the patient.
- ✓ Always hold the bracket with both hands when you manipulate it.
- ✓ Operate the bracket only as described in this user guide.
- ✓ Do not modify the bracket, or any components of Technimount systems. Modifying the product can cause unpredictable operation resulting in injury to the patient or operator.
- ✓ It is the responsibility of the operator of the bracket or any of its options, to ensure equipment being used with the Technimount products meets the installation specifications. Injury may result if non-compatible products are used with Technimount products.
- ✓ Do not attempt to operate, install or remove the equipment while mobile. Ensure that installation and removal of equipment is done while flight or ground emergency service is immobilized.
- ✓ Verify that the bracket is inserted correctly into a mounting system and locked. If equipment is improperly installed and locked, it can cause the equipment to fall and cause injury to the patient or operator and/or damage to the medical equipment.
- ✓ Never use the bracket if not properly installed and locked on a base, a cot/stretchers, or on a wall mount or floor mount. If not installed properly, the medical device could fall during transport and may cause injury to the patient or operator and/or damage to the product.
- ✓ Do not allow untrained staff to assist in the operation of the mounting system. Untrained technicians/staff can cause injury to the patient or themselves.
- ✓ Do not place additional equipment or items onto the bracket or mounts other than approved Technimount or components, as this could damage the product and may result in injury to the patient or operator.
- ✓ Operators must be able to safely lift the total weight of the bracket system and medical device.
- ✓ Do not attach restraints to the bracket frame. It may result in damage to the System and/or result in injury to the patient or operator.
- ✓ Always reposition the equipment with care, avoid any improper pushing or violent manipulation, as it may result in unbalanced equipment and may cause injury to the patient or operator and/or damage to the product.
- ✓ Improper maintenance can cause injury to patient or operator or damage to the product. Maintain the bracket and Mounting Systems as described in this user guide. Use only Technimount approved parts and maintenance procedures. Using unapproved parts and procedures could cause unpredictable operation and/or injury and will void the product warranty.
- ✓ Failure to properly clean or dispose of corrosive products will increase the risk of premature damage and may cause injury to the patient or operator.
- ✓ Any installation on a surface, wall or on the structure of the vehicle has to be validated or inspected in order to ensure it maintains the integrity of the vehicle.

# SUMMARY OF SAFETY PRECAUTIONS

---

## WARNING/CAUTION/NOTE (CONTINUED)

---

### CAUTION

---

- ✓ Only certified technical personnel familiar with the bracket installation and use should manipulate it. Always refer to Technimount's user guides for all instructions for installing and using any Technimount Mounting System.
- ✓ Inspect regularly all components on the equipment for any issue and loose screws, bolts and nuts.
- ✓ Never install the mount into or on other similar mounting systems or brackets without written confirmation by Technimount System as these different systems may be from other brands or models and may not be compatible with Technimount systems.

### NOTE

- ✓ Some cleaning products are corrosive in nature and may cause damage to the product if used improperly. If such products are used to clean Technimount equipment, the equipment must be rinsed with clean water and thoroughly dried following the cleaning. Failure to properly rinse and dry the Mounting Systems will leave a corrosive residue on the surface, possibly causing premature corrosion of critical components.
- ✓ When ordering, it is important to identify on which mounting system you need to mount the bracket on as there are different systems for different applications (ground and flight).
- ✓ A maintenance program should be established for all Technimount equipment. Preventive maintenance may need to be performed more frequently, based on the level of use of the product. Close attention should be given to safety features (i.e.: screws, quick release mechanisms, and attachment points).
- ✓ Failure to use authorized parts, and lubricants, could cause damage to the equipment and will void the warranty of the product.
- ✓ This user guide should be considered a permanent part of the bracket, and should remain with the product even if the equipment is subsequently sold.
- ✓ Technimount continually seeks advancements in product design and quality. Therefore, while this user guide contains the most current product information available at the time of printing, there may contain minor differences between your mounting system and this user guide.

If you have any questions, or for more information, please contact Technimount Customer Service [customerservice@technimount.com](mailto:customerservice@technimount.com).

# NOTICE

---

The Bracket Pro Serie® 112 is designed to comply with the essential requirements and other relevant provisions of the SAE J3043. For more information, please contact Technimount Customer Service ([customerservice@technimount.com](mailto:customerservice@technimount.com)).

## TECHNIMOUNT E.M.S. HOLDING INC.

C/O: Regulatory Affairs

3770, Jean Marchand Street, Suite 100-C

Quebec (QC) G2C 1Y6

Canada

T + 1 581.700.6613

TF + 1 888.639.2758

[technimount.com](http://technimount.com)

[legal@technimount.com](mailto:legal@technimount.com)

---



## WARNING

---

The end user and administrator are responsible to validate regulations and standards for safety in their region, in order to comply with applicable safety regulations. Technimount is not responsible to inform the end user and/or administrator of applicable legislation for safety in their area.

# INSTALLATION GUIDE

---

## REMOVING THE PACKAGING FOR INSTALLATION

1. Unpack boxes and check all items are included for installation.
2. Ensure that all shipping and packaging materials have been properly removed from the product(s) prior to installation.
3. Identify all of the product components and hardware prior to starting the installation.
4. The bracket must work properly before it is put into service.
5. Refer to the identification of components at the beginning of this user guide if needed.

## TOOLS REQUIRED FOR INSTALLATION

Below are the basic tools required for installation. Other tools may also be required. If you have any questions regarding the installation, or need assistance, please contact our Technical Support team at [techsupport@technimount.com](mailto:techsupport@technimount.com).

- ✓ No tools required

### NOTE

- ✓ Electrical tools are not recommended, as there is a potential risk of damage to the threads.
- ✓ During the installation process, Technimount recommends the use of medium strength thread-locking adhesive (blue Loctite) to prevent the screws from loosening during normal use. Put a few drops of medium strength thread-locking adhesive (blue Loctite) on each screw before installation.

## LIST OF MATERIAL

- ✓ Bracket Pro Serie 112

# INSTALLATION GUIDE

## INSTALLATION OF THE CARDIOHELP INTO THE BRACKET

1. Identify all parts.

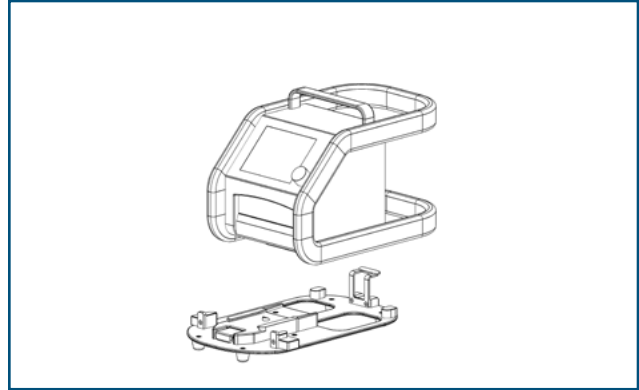

2. To install the Cardiohelp, align and slide the device towards the Red Quick Release mechanism.
3. The device is properly installed once the sound of a click is heard.

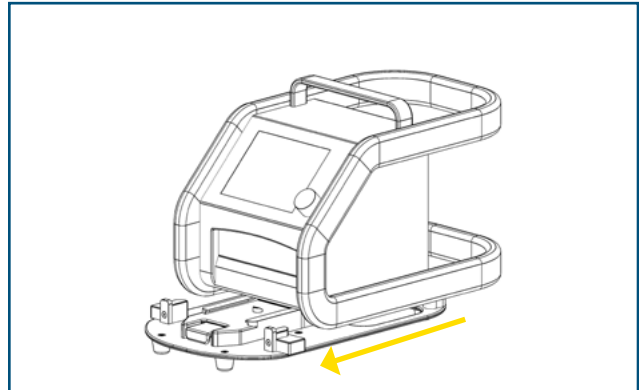

4. Ensure that the medical device is properly installed by slightly pushing backwards.
5. The ECMO/Cardiohelp is ready for use.

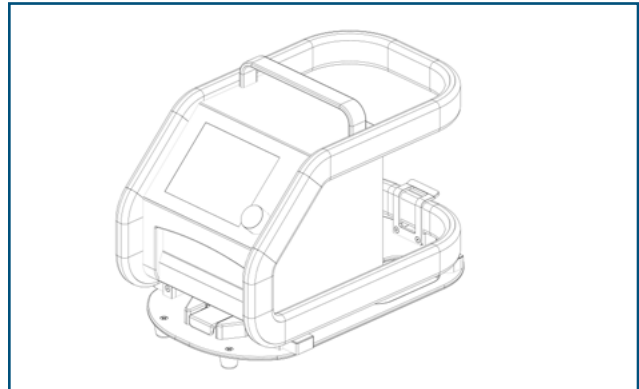

# INSTALLATION GUIDE

---

## REMOVING THE CARDIOHELP FROM THE BRACKET

1. To release the Medical Device from the Bracket Pro Serie 112, press and hold the Red Quick Release Mechanism located at the front of the bracket.

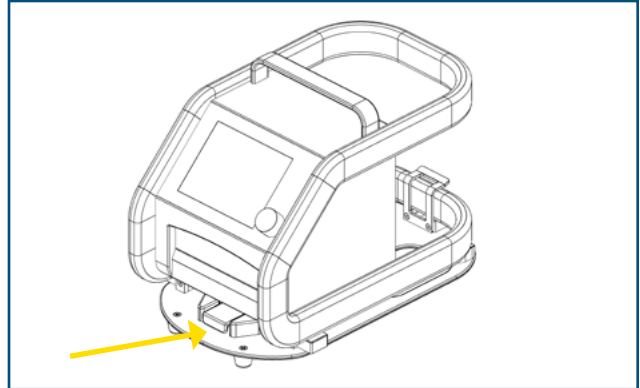

2. Slide the medical device backwards and pull upwards.

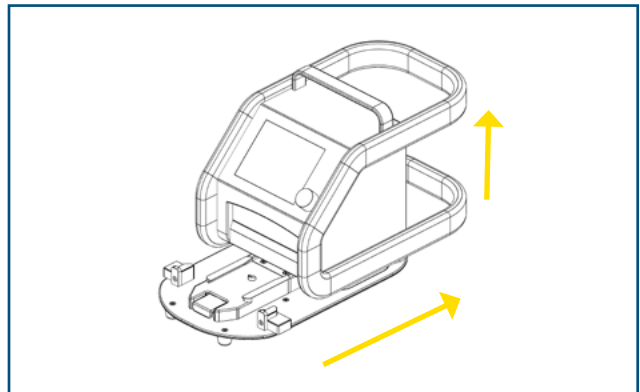

# OPERATION GUIDE

## INSTALLATION OF THE BRACKET INTO THE STANDARD SURFACE BASE

1. The Bracket Pro Serie 112 features an Anti-Rotation Standard Disc compatible with the Standard Surface Base.

### NOTE

This bracket enables only one direction installation.

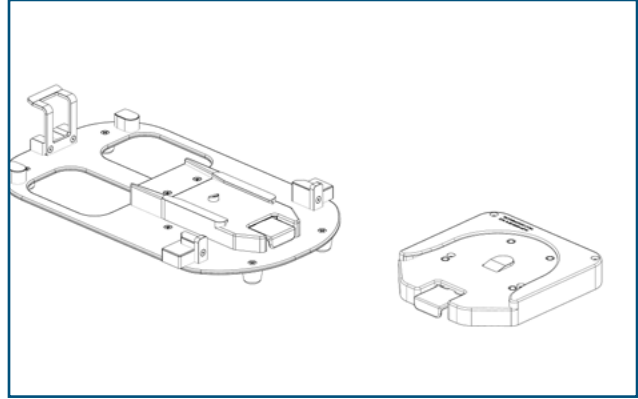

2. To insert the bracket into the Standard Surface Base, slide the base horizontally from the front of the base towards the back.



### CAUTION

Ensure the bracket is locked securely in the Standard Surface Base before manipulating the device or transporting the stretcher.

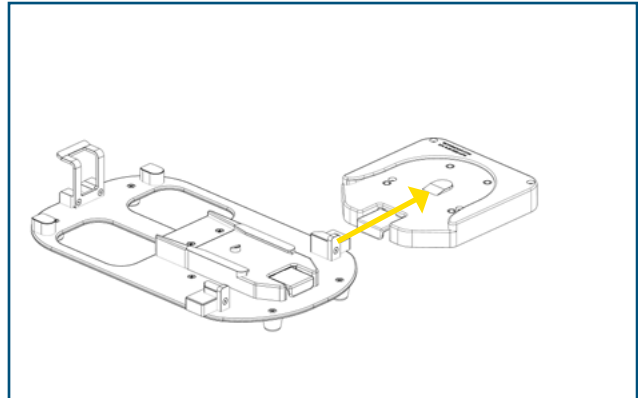

3. The bracket is ready for transport.

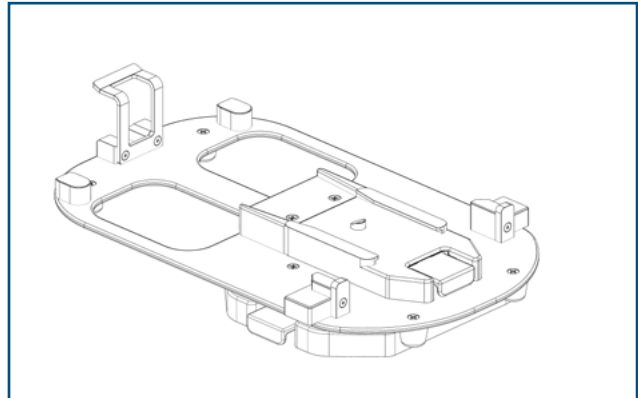

# OPERATION GUIDE

## REMOVING CARDIOHELP FROM THE STANDARD SURFACE BASE

1. To remove the Bracket Pro Serie 112 press and hold the Red Quick Release Mechanism of the Standard Surface Base.

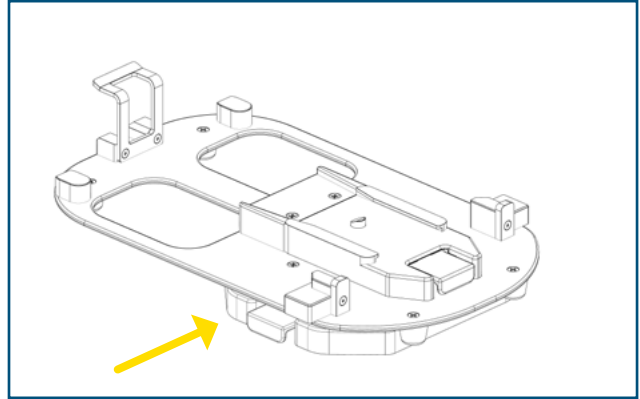

2. Slide the bracket horizontally to remove from base.

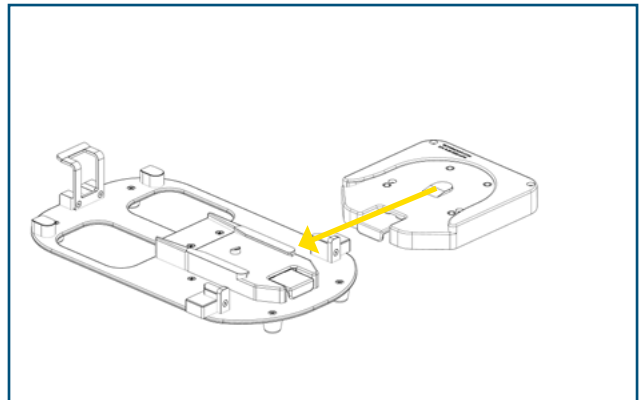

# MAINTENANCE GUIDE

---

## CLEANING

### CLEANING PROCESS

---

#### WARNING

**ENSURE TO REMOVE THE MEDICAL DEVICE FROM THE BRACKET IF THOROUGH CLEANING IS NEEDED.**

Follow your EMS service's protocol or medical device manufacturer's user guide for the recommended cleaning procedure of your medical devices. Cleaning procedure below does NOT provide recommendations for cleaning of the medical device. The following cleaning guidelines consider the Technimount mounting assemblies and components.

It is the responsibility of each hospital to use the cleaning solution of their choice. All hospitals have policies and procedures describing how they should clean and disinfect their medical equipment. In diluted concentrations, these cleaning agents have no negative effect on our products.

The bracket can be cleaned by using a pressure washer. The bracket may show some signs of oxidation or discoloration from continuous washing, however, degradation of the product's performance or functionality will not be affected due to power washing if cleaning instructions are properly followed.

The material used to manufacture the bracket is high-grade aluminum, it is very durable and resistant to corrosion, however high levels of sodium or a high concentration of sodium or acid may prematurely corrode the product. Always rinse with soft soap and water if exposed.

- ✓ Use of a power washer can accelerate removal of contaminants collected during the use of the product.
- ✓ Rinse with clean water.
- ✓ Towel dry all components, and leave to air dry
- ✓ Avoid over saturation and ensure that the product does not stay wet longer than the cleaner manufacturer's guidelines for proper disinfecting.

---

#### WARNING

- ✓ When cleaning, always use appropriate personal protection equipment (PPE) based on established protocols (e.g., gloves, eye wear, etc.).

---

#### CAUTION

- ✓ Do not steam clean or use ultrasonic cleaners on the system or any of its components.
- ✓ Do not immerse the metal parts/components in water.
- ✓ Maximum water temperature should not exceed 180°F/82°C.
- ✓ Maximum water pressure should not exceed 500 psi/34,5 BAR. If a pressure washer is being used to clean the unit, the pressure nozzle must be kept a minimum of 24 inches (61 cm) from the unit.

# MAINTENANCE GUIDE

---

## CLEANING (CONTINUED)

### CLEANING SOLUTIONS

Phenolic type or quaternary type disinfectants can be used (excluding Virex® TB). Iodophor type disinfectants, Peracetic Acid, Chlorine, and especially Hydrogen Peroxide are not recommended for use because staining and corrosion may result.

Suggested cleaners for the bracket:

- ✓ Quaternary Cleaners (active ingredient - ammonium chloride)
- ✓ Water and soft soap
- ✓ A mild 10% bleach solution, a solution containing alcohol or a quaternary ammonium chloride solution. In diluted concentrations, these cleaning agents have no negative effect on our products.

---

### WARNING

- ✓ Some cleaning products are corrosive in nature and may cause damage to the product if used improperly.
- ✓ If the products described are used to clean the equipment, the bracket and components must be rinsed with clean water and thoroughly dried following cleaning. Failure to properly rinse and dry the system will leave a corrosive residue on the surface of the product, possibly causing premature corrosion of critical components.

### REMOVAL OF IODINE COMPOUNDS

If rust appears on any surface of the product, we recommend sanding the affected surface to remove the rust and then using the cleaning method presented in this guide once the rust is removed. To clean the stained area, use a solution of 0.13 oz/3.70ml of Sodium Thiosulfate in 1 pint / .5 litre of warm water to clean the stained area. Clean as soon as possible after staining occurs. If stains are not immediately removed, allow solution to soak or stand on the surface. Thoroughly rinse surfaces with clean water and allow to air dry before returning unit to service.

---

### WARNING

- ✓ Failure to properly clean contaminated parts or components will increase the risk of exposure to blood borne pathogens and may cause injury to the patient or the operator.

## PREVENTIVE MAINTENANCE

A preventive and regular maintenance program should be established for all Technimount equipment. Preventive maintenance may be required more frequently based on the usage level of the product. The bracket requires regular preventative maintenance. Establish and follow a preventive maintenance schedule and keep records of preventive maintenance activities (see maintenance form in this user guide).

---

### CAUTION

- ✓ Close attention should be given to safety features including, but not limited to locking mechanisms and discs.
- ✓ Improper maintenance can cause injury or damage to the product. Maintain the product as described in this user guide.

---

[Return to Table of Contents](#)

# MAINTENANCE GUIDE

## INSPECTION PROCESS AND SCHEDULE

### MAINTENANCE PROGRAM

The following inspection routine and schedule is intended as a general guide for preventive maintenance of the bracket. Factors such as weather, environment, geographical location, and individual usage will necessitate different maintenance. If you are unsure as to how to perform these maintenance inspections or at what interval to perform these inspections, please contact your Technical Support Team at [techsupport@technimount.com](mailto:techsupport@technimount.com). Check each routine and replace damaged or worn out parts if necessary.

Follow timetable below for maintenance (either in months (M) or hours (H)), in accordance with your Service's current maintenance practices and protocols.

| <u>ITEM</u> | <u>ROUTINE</u>  | <u>1 M</u><br><u>OR</u><br><u>2 H</u> | <u>3 M</u><br><u>OR</u><br><u>6 H</u> | <u>6 M</u><br><u>OR</u><br><u>12 H</u> | <u>12 M</u><br><u>OR</u><br><u>24 H</u> |
|-------------|---|---------------------------------------|---------------------------------------|--|---|
| Bracket     | <ul style="list-style-type: none"> <li>✓ Inspect the bracket                             <ul style="list-style-type: none"> <li>▪ Inspect the screws</li> <li>▪ Ensure the bracket is working properly and there are no particles, obstacles, or debris</li> </ul> </li> <li>✓ Verify that the Bottom Anti-Rotation Standard Disc is clean and works properly</li> <li>✓ Verify that the Red Quick Release Mechanism works properly</li> <li>✓ Do a visual inspection of the bracket to ensure there is no damage of chemical attack</li> </ul> | X                                     |                                       |  |   |





# MAINTENANCE GUIDE

---

## REPLACEMENT PARTS

The parts and accessories listed are all currently available for purchase. Some of the parts identified on the assembly drawing parts in this user guide may not be individually available for purchase. Please call Technimount Customer Service: + 1 888.639.2758 or at [customerservice@technimount.com](mailto:customerservice@technimount.com) for availability and pricing.

| <u>DESCRIPTION</u>  | <u>PART NUMBER</u> |
|---|--------------------|
| Bracket Pro Serie 112                                       | 2410-10-MQCH       |
| Replacement Foot 7/8" For Bracket Pro Serie, includes screw | 923-00-78-INS      |

# WARRANTY

---

## WARRANTY POLICY

This statement constitutes TECHNIMOUNT's entire warranty policy with regards to the TECHNIMOUNT Products. TECHNIMOUNT MAKES NO OTHER WARRANTY OR REPRESENTATION NEITHER EXPRESSED NOR IMPLIED, EXCEPT AS SET FORTH HEREIN. THERE IS NO WARRANTY OF MERCHANTABILITY AND THERE ARE NO WARRANTIES OF FITNESS FOR ANY PARTICULAR PURPOSE. IN NO EVENT SHALL TECHNIMOUNT BE LIABLE HEREUNDER FOR INCIDENTAL OR CONSEQUENTIAL DAMAGES ARISING FROM OR IN ANY MANNER RELATED TO SALES OR USE OF ANY SUCH EQUIPMENT.

TECHNIMOUNT E.M.S. Holding Inc. (TECHNIMOUNT) guarantees to the original "Purchaser" of the "Hardware" with which this "Limited Warranty" is included that the Hardware will be free from "Defects" in workmanship and materials under normal use for a "Warranty Period", one (1) year from the date that the Hardware was first purchased by the Purchaser. During the Warranty Period, the Hardware will be repaired or replaced according to the "Limited Warranty" without charge to the Purchaser for either parts or labor. The parts or products may be repaired or replaced with either new or refurbished parts. For this Limited Warranty "refurbished" means parts and products, which have been returned to factory specifications. If the Hardware is repaired or replaced within the Warranty Period, the greater of the remaining warranty period will apply or three (3) months from the date of repair/replacement. If the Hardware is repaired or replaced after the Warranty Period has expired, the Warranty Period for the repair or replacement will expire three (3) months after the date of repair or replacement.

## LIMITED RESPONSIBILITY AND WARRANTY

The Limited Warranty does not apply to normal wear that should result from normal use. It does not apply when the Hardware or any component has been, disassembled, or repaired by someone not authorized by TECHNIMOUNT or if the seal has been broken. It does not cover repair or replacement of any Hardware or part thereof damaged by neglect, misuse, moisture, liquids, exposure to heat, accidents, abuse, and non-compliance with the instructions for installation and use provided with the Hardware. The Limited Warranty does not cover physical damage to the surface of the Hardware and the decision to repair, replace or refuse the coverage is final and at the sole discretion of TECHNIMOUNT, without any compensation or obligation from TECHNIMOUNT.

The hardware, or product defined as a mounting or bracket system for clipping and attaching medical equipment is specifically designed to fill these requirement. Any other use will void the warranty and TECHNIMOUNT will not be held liable on any claim if the product has been modified or adapted for use.

Technimount products are intended to retain a medical device in place in the case of a single crash impact. A Technimount product must NOT be used again if it was involved in a crash. The product MUST be replaced. If the Purchaser uses a Technimount product following a crash, it is at the Purchaser's own risk and Technimount will not be held liable.

## INTERNATIONAL WARRANTY CLAUSE

This warranty reflects Canadian domestic policy. Warranty outside Canada may vary by country. Please contact Customer Service at [customerservice@technimount.com](mailto:customerservice@technimount.com) for more information.

# RETURN POLICY

---

## RETURN POLICY

Mounting systems and bracket systems for portable medical devices may be returned up to 60 days of receipt if:

- The product is not what was originally ordered
- The product does not meet specifications with TECHNIMOUNT's technical sheets
- The product is not compatible with the equipment on which it was to be installed

For any manufacturing defect, refer to the conditions within the Warranty Policy.

### PRIOR TO 30 DAYS

- Product must be undamaged and in its original packaging
- The product return request must be provided in writing and must be approved by TECHNIMOUNT prior to returning the product
- Returns will not be approved on a modified or damaged item
- Charges may apply if damaged or missing item
- Customer is responsible for a 10% restocking fee

### PRIOR 45 DAYS

- Product must be unused, undamaged and in its original packaging
- The product return request must be provided in writing and it must be approved by TECHNIMOUNT prior to returning the product
- Returns will not be approved on modified or damaged item
- Charges may apply if damaged or missing items
- Customer is responsible for a 25% restocking fee

### PRIOR 60 DAYS

- Product must be unused, undamaged and in its original packaging
- The product return request must be provided in writing and it must be approved by TECHNIMOUNT prior to returning the product
- Returns will not be approved on a modified or damaged item
- Charges may apply if damaged or missing items
- Customer is responsible for a 30% restocking fee

## RETURN AUTHORIZATION

TECHNIMOUNT's customer service is responsible for approving returns and will provide a Return Merchandise Authorization (RMA) number to be printed on any returned merchandise. TECHNIMOUNT reserves the right to charge shipping and restocking fees on returned items. SPECIAL, MODIFIED, OR DISCONTINUED ITEMS ARE NOT SUBJECT TO RETURN.

# RETURN POLICY

---

## DAMAGED MERCHANDISE

ICC Regulations require that claims for damaged merchandise must be made with the carrier within fifteen (15) days of receiving merchandise. DO NOT ACCEPT DAMAGED SHIPMENTS UNLESS SUCH DAMAGE IS NOTED ON THE DELIVERY RECEIPT AT THE TIME OF RECEIPT. Upon prompt notification, TECHNIMOUNT will file a freight claim with the appropriate carrier for damages incurred. Claims will be limited in amount to the actual replacement cost. In the event that this information is not received by TECHNIMOUNT within the fifteen (15) day period following the delivery of the merchandise, or the damage was not noted on the delivery receipt at the time of receipt, the customer will be responsible for payment of the original invoice in full.

Note: Claims for any short or broken shipment must be made within thirty (30) days of invoice.

## CLAIM PROCESS

Please follow the claim procedure below to return a defective product:

Download the form at <https://www.technimount.com/wp-content/uploads/2021/12/Technimount-RMA-EMS-FOR-03-03.pdf>

### REQUIRED INFORMATION

- Serial number
- Invoice number
- Identification of the issue
- Upload the pictures of the issue
- Submit the form

A confirmation of the receipt of the claim will be sent to you within 2 business days. If you have not received a confirmation e-mail by then, please contact [techsupport@technimount.com](mailto:techsupport@technimount.com).

If the RMA request is approved, TECHNIMOUNT will provide you with an RMA number for your claim. We will also include instructions for the replacement of your product. No product return will be accepted without the RMA number labeled on the outside of the box being returned.

### FINDINGS AND CONCLUSION

- If following an investigation, we find that our product is defective, TECHNIMOUNT will take corrective actions and close the claim.
- If following an investigation, we find that our product is NOT defective (misuse or abuse of the product) the product will not be covered by the warranty. Details of our findings and conclusions will be provided to you.

## QUESTIONS ABOUT OUR POLICY

If you have any questions regarding our return policy, please contact Customer Service at [customerservice@technimount.com](mailto:customerservice@technimount.com).





# SAFETY AND FLEXIBILITY WHERE IT MATTERS MOST

TECHNIMOUNT E.M.S. HOLDING INC.  
3770 Jean-Marchand Street, Suite 100-C  
Quebec (QC) G2C 1Y6  
Canada  
T + 1 581.700.6613  
TF + 1 888.639.2758  
[technimount.com](http://technimount.com)  
[info@technimount.com](mailto:info@technimount.com)

© 2022 Technimount E.M.S. Holding Inc. - All Rights Reserved  
Printed in Canada



UG-BP112-202211-01