



# POWER X1

Powered Ambulance Cot



**FERNO**<sup>®</sup>

May 2025 | 234-3684-08



## Ferno Customer Relations

Ferno-Washington, Inc., 70 Weil Way  
Wilmington, Ohio 45177-9371, U.S.A.

Information [www.ferno.com](http://www.ferno.com)  
Authorized Service and Support [ferno.com/service-and-support](http://ferno.com/service-and-support)

U.S., Canada	1.877.733.0911
International	Country Code +1.937.382.1451
Fax	1.888.388.1349

### INSTRUCTIONS FOR USE



Read this Manual and Retain for Future Reference. To request additional free manuals, contact Ferno.



### Medical Device



Ferno-Washington, Inc.  
70 Weil Way  
Wilmington, OH 45177-9371, U.S.A.  
1.937.382.1451



FERNO S.r.l.  
Via B. Zallone n.26  
40066 Pieve di Cento (BO), Italy  
+39 (051) 6860028



Ferno (UK) Ltd.  
Ferno House, Stubs Beck Lane, Cleckheaton,  
West Yorkshire, BD19 4TZ, UK  
+44 (0) 1274 851 999



## Disclaimer

This manual contains general instructions for the use, operation and care of this product. Instructions are not all-inclusive. Safe and proper use of this product is solely at the discretion of the user. Safety information is included as a service to the user. All other safety measures taken by the user should be within and under consideration of applicable regulations and local protocol. Training on the proper use of this product must be provided before using this product in an actual situation.

Retain this manual for future reference. Include it with the product in the event of transfer to new users. Additional free copies are available upon request from Customer Relations.

## Proprietary Notice

The information disclosed in this manual is the property of Ferno. Ferno reserves all intellectual property rights, proprietary design rights, manufacturing rights, reproduction use rights, and sales use rights thereto, and to any article disclosed therein except to the extent those rights are expressly granted to others or where not applicable to vendor proprietary parts.

## Limited Warranty Statement

Ferno products are covered by a limited warranty, printed on all Ferno invoices. Complete terms and conditions, and limitations of liability, are available from Ferno.

## Adverse Event Notice

In the event of an adverse event or serious incident related to the use of this device, the end user/operator must report the incident to Ferno at 1-877-733-0911, or via email at [tscoordinator@ferno.com](mailto:tscoordinator@ferno.com). If the incident occurred outside the U.S., report it to Ferno's Authorized Representative for that area.

## Disposal

Prior to disposal, clean and disinfect the product according to the Maintenance section of this manual. Recycle or dispose of the product following local protocols and regulations. Do not dispose of the product in municipal waste.

Remove and recycle batteries and electronic components according to local protocols and regulations. Contact your local government for recycling and disposal information. Do not dispose of batteries in municipal waste.



## Unique Device Identification (UDI)

**FERNO** Product Name/Model UDI

Date of Manufacture		(01) Global Trade Item Number
Serial Number		(11) Date of Manufacture
		(21) Serial Number

Ferno-Washington Inc. | Wilmington, Ohio 45177 USA | +1.937.382.1451

**FERNO** Product Name/Model UDI

Date of Manufacture		(01) Global Trade Item Number
Lot Number		(11) Date of Manufacture
		(10) Lot Number

Ferno | Wilmington, Ohio 45177 USA | +1.937.382.1451

# 1 - SAFETY INFORMATION

## 1.1 Warning

Warning safety alerts indicate a potentially hazardous situation that, if not avoided, could result in injury or death.



### WARNING

**Professional use by trained operators only. Maintain control of cot and controls. Direct helpers where to grasp to avoid pinch points. Consider terrain and use a lowered position to minimize potential to tip.**

**Exceeding the load capacity can cause injury and damage. Inspect the cot if the load capacity has been exceeded.**

**Use the cot only for its intended purpose. Improper use, operation, or maintenance can cause injury. Use, operate, and maintain only as instructed.**

**Failure to use the safety hook (provided) can cause injury. Install and use the safety hook as described in the safety hook manual. Operators must visually confirm the safety bar on the cot is captured by the safety hook during every loading and unloading sequence.**

**Improper parts, modifications or items not designed for the cot can cause injury. Use only Ferno-approved parts and service. Attach only approved items to the cot. Do not modify the cot.**

**Improper charging can cause injury and damage. Charge the battery only with an approved adapter and Ferno Battery Charger or compatible 36VDC Integrated Charging System (ICS).**

**Modifying the battery can cause injury and damage. Use the battery only as designed by Ferno.**

**Unsecured equipment can cause injury. Remove equipment from the equipment hook before transport inside a motor vehicle and secure in an appropriate device.**

**An unattended or unrestrained patient can be injured. Always stay with the patient and use patient restraints.**

**Rolling sideways or pushing by the backrest can cause the cot to tip. Roll only toward the control or operator end and grasp the main frame when rolling.**

**Sheets or other objects can interfere or become entangled in mechanisms and cause injury or malfunction. Tuck sheets between the mattress and the patient surface. Keep restraints and other articles above the mattress.**

**Improper bariatric transport can cause injury to the patient, operators and helpers. Follow local protocols and the instructions in this manual. Keep the cot folded when exceeding the standard load capacity. Use as many additional operators and helpers as needed to safely transport the patient.**

## 1.2 Notice

Notices emphasize important, but not hazard-related information. Failure to follow Notices could result in product or property damage.

### NOTICE

## 1.3 Compliance

When properly installed and used with appropriate Ferno products, the cot meets or exceeds the following specifications and standards.

Note: Standards are updated periodically. Current standards are available from these organizations.



















### STANDARDS MET\*











- **AMD:** Ambulance Manufacturer's Division (AMD) of the National Truck Equipment Association Standard 004 (Oct. 2014), Litter Retention System Static Test.
- **CAAS:** Commission on Accreditation of Ambulance Services Global Vehicle Standard (GVS) v1.0
- **IP56:** Ingress Protection rating. Tested in compliance with dust and water infiltration standards.
- **KKK-A-1822 (F):** Federal Ambulance Specification KKK-A-1822 revision F (2007), Change Notice 11 as applicable.
- **NFPA:** National Fire Protection Association standard NFPA® 1917 (2016 edition).
- **SAE J3027:2016:** Society of Automotive Engineers Recommended Practice, Ambulance Litter Integrity, Retention, and Patient Restraint
- **IEC 60601-1-2:** Temperature and vibration testing
- **ISTA 1B:** International Safe Transit Association shipping/packaging test compliance
- **Alberta:** Alberta Health and Wellness Ambulance Vehicle Standard Code January 2010; Section 17.5 Cot Retention System Test
- **BCAS:** British Columbia Ambulance Service (BCAS) Ambulance Performance Test Criteria E2 Stretcher Retention
- **Ontario:** Ontario Land Ambulance Standard, Version 5.0, September 28, 2012; Section 20.1 Main Cot Retention
- **AS/NZS 4535:1999.** Meets the requirements of the Ambulance Restraint Systems test.
- **IP56:** Ingress Protection rating. Tested in compliance with dust and water infiltration standards.
- **CE:** POWER X1 when used with Ferno® PRO F1 Fastening System Meets European Norms.
- **RoHS-2:** Meets the requirements of RoHS-2 (EU Directive 2011/65/EU) on the restriction of the use of certain hazardous substances
- **EN 1789 and EN 1865:** Vehicle, fastening system, and crash-test standards.

\* **Note:** SAE-Compliant version only at standard load capacity. Cot must be configured for use with the Ferno® PRO F1 Fastening System.

## 1.4 Symbol Glossary

Ferno uses, as applicable, the following safety and regulatory symbols.

Symbol	Definition
	General warning of potential injury
	Pinch point; keep hands clear
	Do not push cot by the backrest
	Do not lubricate
	Do not pressure wash (Battery)
	Remove items from equipment hook before transport
	Consider instructions for use (ISO 7000)
	Read Users' manual (ISO 7000)
	Refer to instructions for use (ANSI Z535/ISO 3864)
	Two trained operators required
	Lubricate
	Pressure-wash permitted (cot only)
	Lock
	Unlock
	Standard Load Capacity (Safe Working Load in pounds, kilograms, stone)
	Bariatric Load Capacity (Safe Working Load in pounds, kilograms, stone)
	Extend legs
	Retract legs
	Program button

Symbol	Definition
	Follow training protocol
	Disinfecting
	Cleaning
	Restraint attachment point
	Lift here (non-powered lifting)
	Directional wheel lock
	Temperature limit (low/high)
	Check button (battery)
	Service required (battery)
	European Directive 2012/19/EU on Waste Electrical and Electronic Equipment. Do not dispose of product in municipal waste. See "Disposal" on page 2.
IP##	Ingress Protection Rating

## 2 - OPERATOR TRAINING

### 2.1 Operator Training

Operators must: read and understand this manual, have the physical ability to assist the patient, be trained on proper cot operation, be trained on emergency-medical service and patient-handling procedures, and practice with the cot before using it with a patient. Keep training records.

The cot is designed to minimize the need for lifting. Use the powered hydraulic system whenever possible. A load exceeding 700 lb/318 kg load capacity, or non-powered operation, may require the operators to lift a portion of the load. Use additional trained help as needed.

### 2.2 Daily Operator Duties

Unload the cot from the ambulance and inspect it for readiness, rotate the cot in a circle to verify it rolls easily, and check the function of the manual back-up handle. Conduct the Daily Electrical Inspection (page 29). Load the cot into the ambulance and confirm it is secure in the fastening system. Confirm the main battery is charged by the Integrated Charging System (if equipped).

### 2.3 Using Additional Help

Operation requires a minimum of two trained operators. Use help when working with heavy loads (patient plus equipment), or when operating the cot manually. Trained operators stand at the ends of the cot, maintain control of the cot, operate the controls, and direct helpers on where to stand and how to grasp the cot.

Refer to the chart for suggested placement for operators and helpers.

 **WARNING**

**Professional use by trained operators only. Maintain control of cot and controls. Direct helpers where to grasp to avoid pinch points. Consider terrain and use a lowered position to minimize potential to tip.**



**Exceeding the load capacity can cause injury and damage. Inspect the cot if the load capacity has been exceeded.**

**NOTICE**

If the ambulance is parked on an uneven surface, the operators (and any helpers) may need to extend or retract the legs from the user-set loading height to allow the cot to roll into the ambulance.

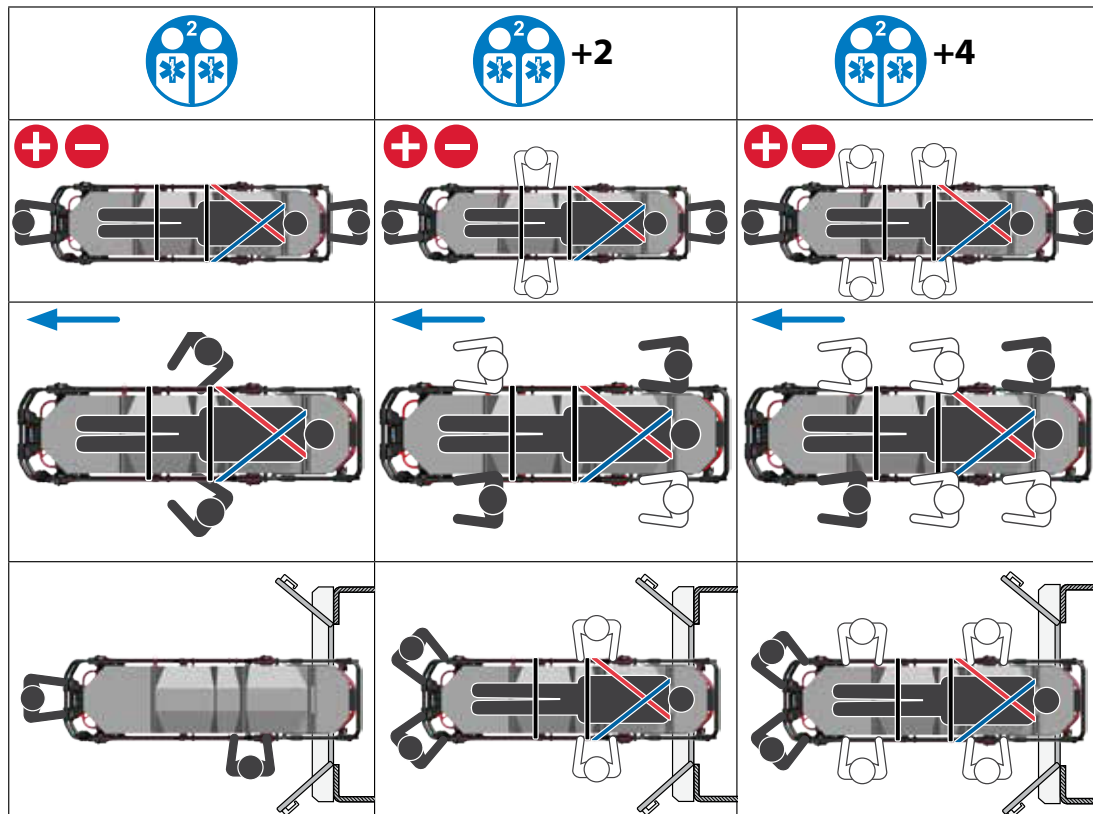

## 3 - ABOUT THE COT

### 3.1 Description

The Ferno® POWER X1™ Cot is an emergency patient-handling device designed to transport a patient in a ground-based ambulance.

The cot is for professional use by a minimum of two trained operators and is designed for use with Ferno fastening systems (not included).

The hydraulic power-lift system helps reduce the risk of back injury to medical service personnel by raising and lowering the cot, reducing the amount of lifting and bending for the operators. A manual back-up system is available for non-powered operation.

**Included with purchase:** users' manual, 36VDC Li-ion ENDURACHarge Battery, AC-input Ferno charger, safety hook for use with antler-and-rail (Ferno Model 175) fastening system, any optional equipment selected at time of purchase, and a set of patient restraints.

#### FEATURES

- Hydraulic actuator with RapidLift high-speed retract
- Easy-access battery port
- Manual back-up for non-powered operation
- 2 sets of height-control buttons **+** **-**
- Patient surface height range 412 mm-1120 mm (16.25"-44")
- Programmable loading height up to 902 mm (35.5")
- 5-position ERGOFrame at loading end
- Sure Grip lift bars and ERGOFrame grasping surfaces
- Anodized handling surfaces keep hands and clothes clean
- Battery status lights integrated into ENDURACHarge battery
- Adjustable pneumatic backrest
- Backrest-mounted equipment hook
- Lead handle
- 6-inch swivel transport wheels
- Wheel locks (control end)
- Set of SAE-compliant patient restraints
- Loading-end scuff guards
- Bolster mattress

#### CONFIGURATIONS

- **SAE Version.** Compatible with Ferno® PRO F1™ fastening system and legacy non-SAE antler and rail (Model 175)
- **Non-SAE Version.** Compatible only with legacy antler and rail (Model 175) fastening system.
- **Sidearm.** Choice of fold-down or SX Surface Xtender.
- **Shock Frame.** Choice of 2-position standard, or 3-position with knee-gatch feature.
- **Directional wheel locks (loading end).** Choice of with or without.
- **Accessories.** Your cot may be shipped with accessories per your order, such as a spare battery. These items are also available separately. See "Accessories" on page 34.



#### WARNING

**Use the cot only for its intended purpose. Improper use, operation, or maintenance can cause injury. Use, operate, and maintain only as instructed.**

#### NOTICE

All cots are compatible with legacy antler-and-rail fastening systems, but these fastening systems do not meet SAE standards. For SAE compliance, a cot compatible with the Ferno PRO F1 fastening system is required.

### 3.2 General Specifications

Product specifications are shown in the tables below. General specifications are rounded. Metric conversions are calculated before rounding the Imperial measurement. Ferno reserves the right to change specifications without notice. For more information, contact Ferno (page 2).

Loading Position is the distance from ground to bottom of loading wheel. Bed Position is the distance from ground to patient surface at the seat panel. Weight is without mattress, patient restraints and optional features. All Ferno® mattresses are fully-sealed.

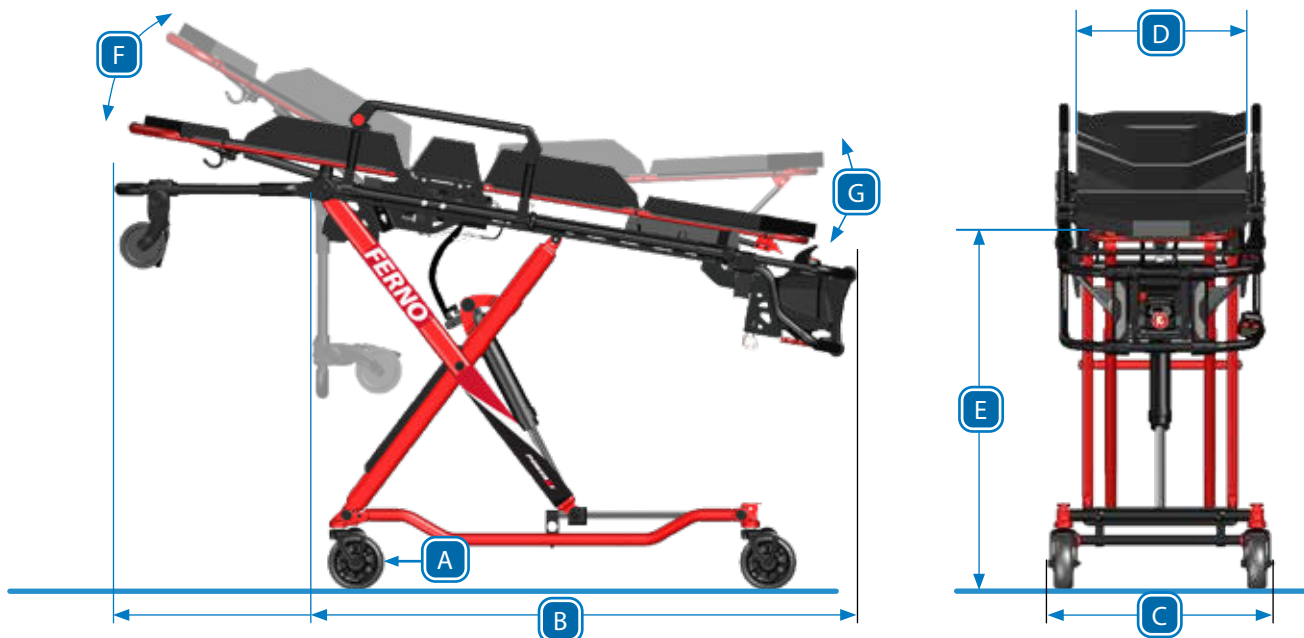

Dimensions	Metric	Imperial
A) Wheels	152 x 43 mm	6" x 1.7"
B) Length (Minimum-Maximum)	1483 mm – 2030 mm	58.5" – 80"
C) Width (Overall)	607 mm	24"
D) Width (Patient Surface)	435 mm	17"
E) Height (Minimum-Maximum)	412 mm – 1120 mm	16.25" – 44"
F) Backrest Adjustment	0°–77°	
G) Shock Frame Adjustment	+13° Standard; 30° (Knee-Gatch Option)	
Loading Height (User-Programmable)	902 mm Maximum	35.5" Maximum
Load Capacity (Unassisted)	318 kg/50 st	700 lb
Bariatric Load Capacity (Fully Retracted)	500 kg/78.6 st	1,100 lb
Cot Weight	65 kg	143 lb

Power System	
Charger Operating Range	-34°C to 60°C / -29°F to 140°F
Charger Output	39.6VDC, 2A
Battery Operating Range	0°C to 55°C / 32°F to 131°F
Battery Output	39.6VDC, 2.5Ah (Amp Hours)
Maximum Duty Cycle	<60 sec ON; >300 sec OFF
Charging Time (1 transport, charge maintained by ICS®)	As little as 15 minutes
Charging Time (depleted)	Up to 1 hour, 45 minutes
Input	12VDC
Input (with optional adapter)	~100-240VAC, 50~60 Hz, 92W

Soft Goods		
Mattress	3.27 kg / 7.2 lb	1854 x 457 x 127 mm / 73" x 18" x 5"

Construction	
Frame, Legs, Bed Surface	Aluminum
Wheels	Sealed, stainless steel bearings; nonconductive wheels
Mattress (bolster)	Heat-sealed vinyl exterior Polyurethane foam pad interior

## 4 - INITIAL SETUP

### 4.1 Ambulance Information

The patient compartment should have a level floor large enough for the fully-lowered cot, and a compatible Ferno fastening system installed (not included).

**U.S.A. Compliance:** Refer to KKK-A-1822 revision F, section 3.9.6 regarding the permissible height and length of the ambulance bumper. Ferno cots are designed to be compatible with ambulances that meet these KKK specifications.

- Bumper step depth must be 5"-10" (127 - 254 mm). If the bumper step depth is more than 7" (178 mm) it must have the ability to fold.
- Bumper step height must be equidistant between the ground and ambulance deck (floor),  $\pm 2"$  (51 mm).
- Bumper step height must not exceed 22" (559 mm).

### 4.2 Safety Hook Requirements

A safety hook is provided for use with antler-and-rail (Ferno Model 175) fastening systems. If you have a Ferno PRO F1 fastening system, refer to the PRO F1 installation manual to install the safety hook provided with this fastening system.

A safety hook secures the cot inside the ambulance during the loading and unloading process while the operators extend or retract the legs. A correctly-positioned safety hook allows the cot to be loaded into the ambulance and unloaded from the ambulance without interference, but will catch the cot-mounted safety bar during every loading and unloading sequence.

A safety hook must be installed and used with the cot. Remove any previously-installed safety hook and determine if the mounting holes may be re-used. Drill new holes if needed for proper hook placement as instructed in this manual.

Several safety hook versions are available to accommodate variations in ambulance design "Parts and Service" on page 32.

- Installation requires the skills of a mechanic familiar with ambulance construction.
- Consult the ambulance manufacturer regarding the location of wiring, oxygen or fuel lines, any other elements under the ambulance floor, and about the ambulance warranty.
- Remove any other safety hook before installing the safety hook. New mounting holes may be required for proper positioning.
- Do not modify the Ferno cot or safety hook. Modify the ambulance if needed. Before modifying the ambulance, contact the ambulance manufacturer for assistance.
- The safety hook must be installed level on the ambulance floor. After following the placement directions, if the door sill interferes, modify the ambulance, not the hook, as follows:
  - Insert a metal shim (not provided) under a portion of the safety hook to make the safety hook sit level on the floor.
  - Modify the door sill to allow the safety hook to sit level. Contact the ambulance manufacturer for confirmation that any adaptation will not interfere with door function.

### WARNING

**Failure to use the safety hook (provided) can cause injury. Install and use the safety hook as described in the safety hook manual. Operators must visually confirm the safety bar on the cot is captured by the safety hook during every loading and unloading sequence.**

**Improper parts, modifications or items not designed for the cot can cause injury. Use only Ferno-approved parts and service. Attach only approved items to the cot. Do not modify the cot.**

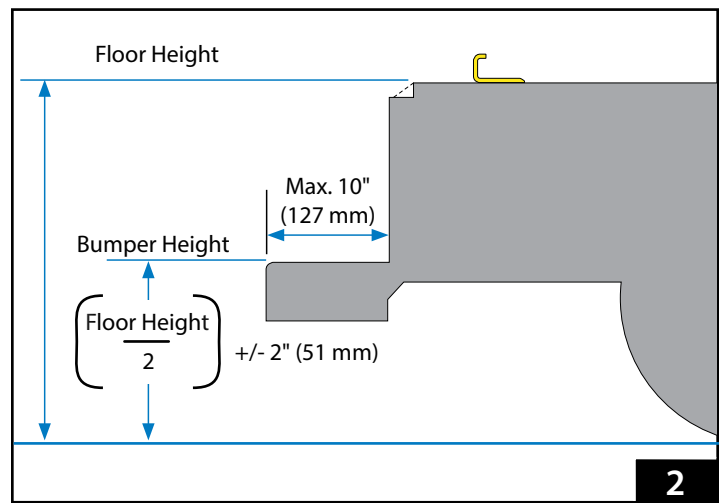

### 4.3 Positioning the Safety Hook

Install the safety hook to meet both requirements:

1. **Front-To-Back:** Position the safety hook face a minimum of 3.75" (95 mm) from the door sill edge. The face is the inner surface where the safety bar catches the hook (Figures 3-4).
2. **Side-To-Side:** The hook must engage the center of the cot safety bar during every loading and unloading sequence. Load and unload the cot in various positions and angles (including centered, all the way to the left and right) and note the location of the loading wheels and safety bar(s).

### 4.4 Installing the Safety Hook

Use installation hardware of at least SAE Grade 5 with UNC-2 threading or equivalent (not supplied). Screws must be long enough to pass through the safety hook, patient compartment floor, both washers and still have at least two full threads extending past the nut.

1. Mark mounting points that meet both front-to-back and side-to-side requirements. For excess doorway width, modify the ambulance by placing a guide, shield, bumper, etc. to guide the cot toward the hook. Do not modify the cot or safety hook.
2. Confirm the mounting positioning is correct.
3. Drill mounting holes at the proper marked locations.
4. Orient the safety hook with the hook toward the front of the ambulance (Figure 4).
5. Attach the safety hook to the floor with an appropriate socket-head screw (Figure 4, left) or flat-head screw (Figure 4 right) screws, flat and lock washers, and jam nuts of the appropriate length and type.
6. Test the hook before placing the ambulance with hook in service. Load the cot into, and unload it from, the ambulance. Verify that there is no interference with extending or retracting the legs.

#### NOTICE

If the hook is installed too far inside the ambulance, you will not be able to properly extend or retract the cot legs. After installation, confirm there is sufficient clearance for the cot legs to fold and unfold.

Install the safety hook only with hardware of at least SAE Grade 5 with UNC-2 threading (or equivalent). Hardware is not supplied.

Two door-sill styles are in use: a straight/square style, and a sloped style. Begin the front-to-back measurement where the flat floor (ambulance deck) meets the door sill. Follow the instructions in this manual.

#### Parts Required (Not Supplied)

1/4"-20 Socket or flat-head screw	2
Flat washer	2
Lock washer	2
1/4"-20 Nut	2
Drill and bits for your particular installation	As needed

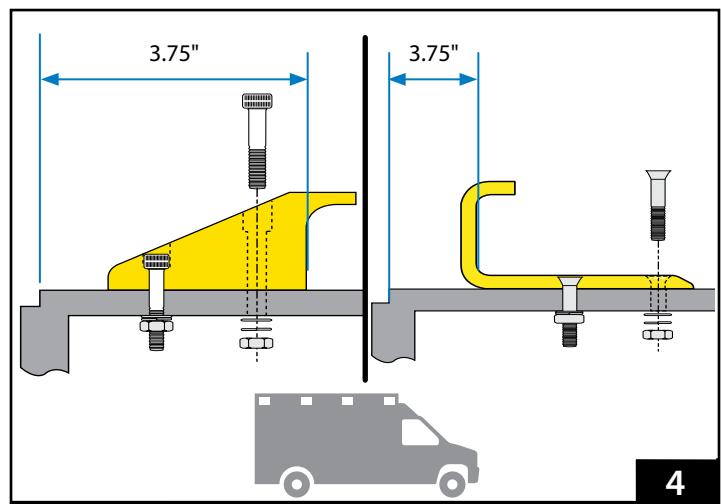
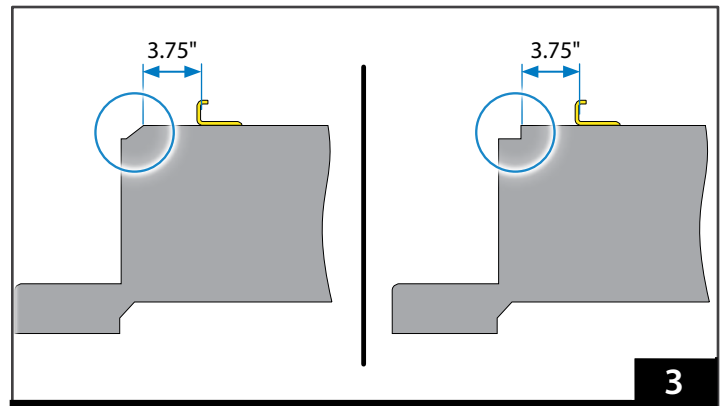

## 4.5 Charge the Battery

Immediately charge the battery upon receipt until it has a full charge. To comply with shipping regulations, the battery must be shipped with less than a 30% charge. Use only the provided battery charger or an ICS-powered fastening system.

The charger is compatible with standard household electricity and is supplied with an input cable for your country. For complete information, refer to the supplied charger and battery manuals.

### NOTICE

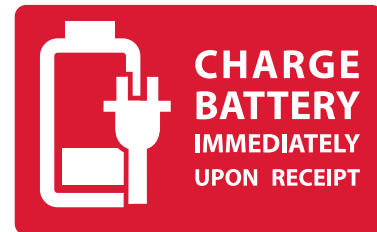

Loose items and debris on the patient compartment floor can interfere with the operation of the cot with the fastening system. Keep the patient compartment floor clear.

Charge the battery immediately upon receipt. Shipping regulations require the battery to be shipped with a 30% charge. Failure to charge the battery in a timely manner can damage the battery.



## 4.6 Set the Loading Height

The user can set the cot so it stops automatically at the proper loading height for the assigned ambulance. To set or change the loading height:

1. On a level surface, raise or lower the cot until the loading wheels roll directly onto the ambulance floor (Figure 5). Verify that the loading wheels are resting on the ambulance floor, the safety bar is caught by the safety hook, and that the loading-end legs have not lifted off the ground.
2. Press and hold both program buttons  for 6 seconds. Release the buttons when the wrench icon () illuminates (solid) to confirm the new setting. If the icon flashes quickly, release the buttons and try again.
3. Retract and extend the legs to verify the cot stops at the new loading height. Test loading and unloading the cot with the ambulance.

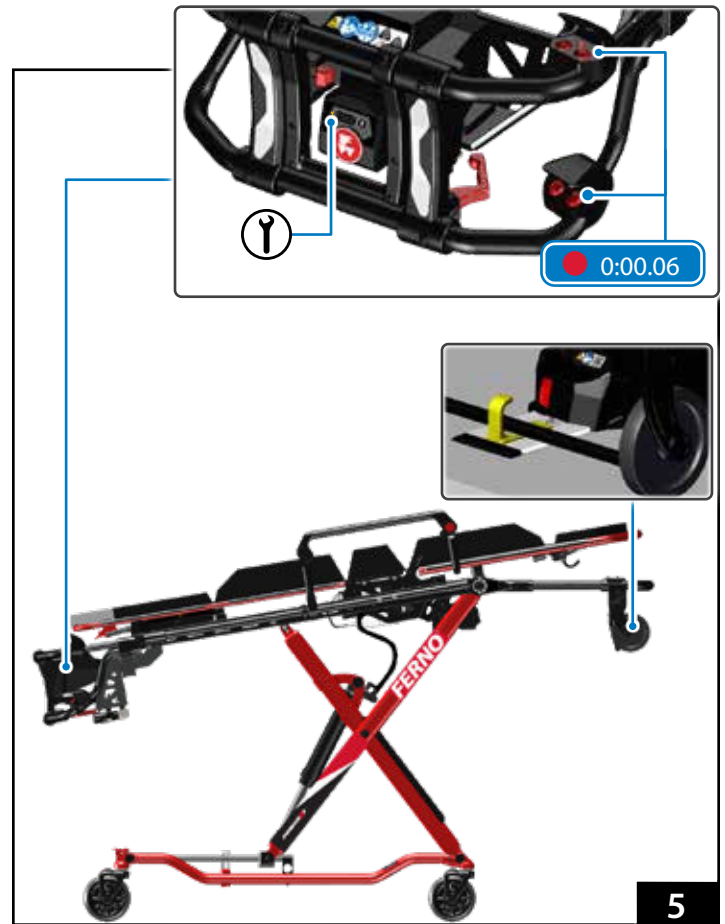

## 4.7 Mattress, Restraints, Accessories

Before placing the cot in service, assign appropriate personnel to install the mattress (page 17), patient restraints, and any accessories shipped with the cot. Keep restraint and accessory users' manuals with this manual for future reference. For additional, free manuals, contact Ferno. See "Ferno Customer Relations" on page 2.

A set of patient restraints is provided. Attach all patient restraints with the buckles at the same side for operator convenience and efficiency.

### SHOULDER AND PELVIC RESTRAINTS

Shoulder and pelvic strap brackets attach to posts on the cot backrest (KK), (Figure 6) and main frame (LL), (Figure 7). Match the restraint strap color to the label at each attachment post (blue, red or black).

1. Pass each shoulder strap male buckle/tang through a slot in the mattress and backrest (MM), and attach the bracket to a matching-color post (KK) on the backrest crosstube (Figure 6).
2. Attach the opposite end of each restraint to color-coded posts on the cot main frame (LL), (Figure 7).
3. Orient the bracket with the bend facing the center of the cot, and with the webbing up. Slide the bracket over the post and pull the bracket upward to seat the post in the small end of the bracket (Figure 7). If you have difficulty attaching the brackets to the posts, stand on the opposite side of the cot from the post. Pull upward and toward yourself to attach the bracket to the post.
4. Verify the brackets are seated on the posts and the strap is not twisted.
5. Keep restraints buckled when not in use.

### TWO-PIECE LEG RESTRAINT

1. Unbuckle the restraint and separate the straps.
2. Wrap the loop end of a strap around the designated attachment point on the cot shock frame or seat panel.
3. Thread the male buckle/tang or female buckle/receiver through the loop and pull the webbing through the loop until the loop is snug around the attachment point (Figure 8).
4. Repeat Steps 2 and 3 to attach the other strap to the selected attachment point on the opposite side of the cot.

### REMOVING RESTRAINTS

1. Unbuckle the buckles.
2. To detach shoulder and pelvic straps, press the brackets down toward the cot main frame to unseat the post from the bracket, then remove the bracket from the post.
3. To remove the leg restraint, unbuckle the restraint. Feed the buckle (or tang) through the loop, and remove the loop from the cot.

### WARNING

**An unattended or unrestrained patient can be injured. Always stay with the patient and use patient restraints.**

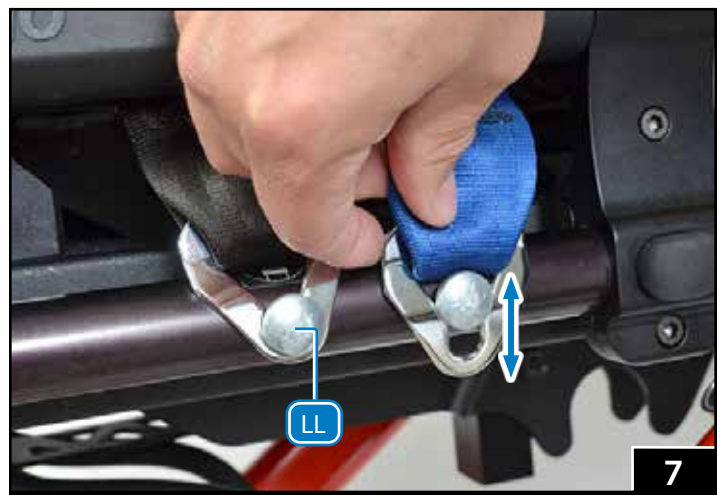
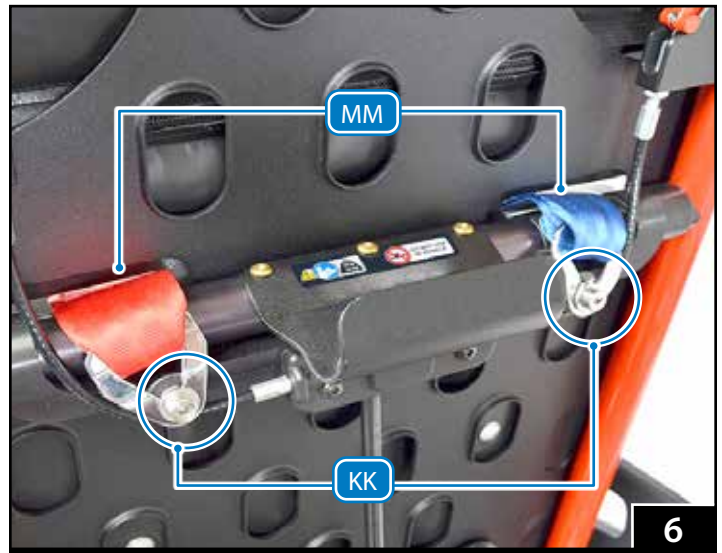

## 5 - OPERATIONS

### 5.1 Height-Control Buttons

The cot does not have an ON/OFF switch. The cot is ready for use whenever a charged battery is attached, and enters Sleep Mode when not in use to preserve the battery.

Height-control buttons (A) are located on the upper and lower lift bars (Figure 9). Button function is identical for each set.

- + EXTEND:** Extends the legs.
- RETRACT:** Retracts the legs.
- PROGRAM:** Use the program button to set an automatic stop at the loading height for a designated ambulance. See page 10.

### 5.2 Lead Handle

Use the lead handle (B) to pull the cot when it is on a level surface (Figure 10). Stow the lead handle on top of the battery enclosure or between the upper and lower lift bars.

Ferno recommends operators keep both hands on the cot main frame, lift bars and/or ERGOFrame at all times when a patient is on the cot. Follow local protocols for patient-handling and transport.

### 5.3 Lift Bars

The upper and lower lift bars (C) allow the control-end operator to use proper ergonomic lifting techniques to lift the cot (Figure 10).

Allow the powered hydraulic system to extend and retract the cot. If the load (patient plus equipment) exceeds the load capacity, the operators and any helpers may need to provide lift-assistance.

### 5.4 Manual Back-Up Handle

The manual back-up handle (D) disengages the cot's power system and allows operators to raise or lower the cot manually (Figure 10). To use manual back-up, see page 24. Use additional trained helpers as needed (page 5).

#### NOTICE

Pressing the extend or retract buttons while the cot is locked in a fastening system can damage the cot and fastening system. Do not press buttons while the cot is locked in the fastening system.

The button lockout feature is available only with Ferno fastening systems with powered Integrated Charging System (optional).



9

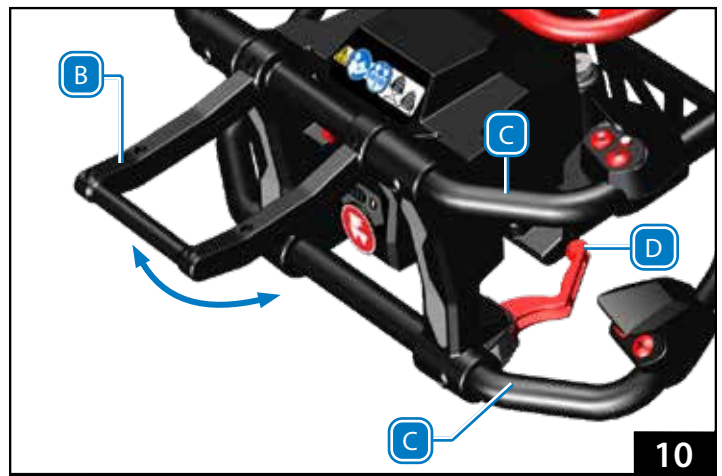

10

## 5.5 Battery



The Ferno ENDURACHarge 36VDC Li-ion battery (E), (Figure 11 and Figure 12) is a rechargeable 36-Volt Direct Current lithium-ion battery.

To eject the battery, slide the red release lever to the left (Figure 11), (F).

To install the battery, align the battery with the port and push it in until it locks. You do not need to use the battery release lever.

When secured in Ferno fastening system with a powered ICS, the cot powered hydraulic system is disabled. See the battery users' manual (publication 234-3689) for additional information.

Battery Features (Figure 12):

-  Battery Check Button (G): Press to illuminate between 1-4 indicator lights (H) that represent the approximate battery charge. Indicator lights also illuminate during charging to show the battery is being charged.
-  Wrench icon (I): Indicates faults, damage or other messages. If illuminated during normal use, swap for a different battery and inspect the battery. If the problem persists, inspect the cot.
- Sleep Mode: After a period of inactivity, the cot enters Sleep Mode to conserve battery power. Press any button (+, -, ●) to wake the cot from Sleep Mode.
- Storing the Battery: Charge the battery before storage. Store only a fully-charged battery (page 31).

### NOTICE

Charge the battery immediately upon receipt. Shipping regulations require the battery to be shipped with a 30% charge. Failure to charge the battery in a timely manner can damage the battery.

To charge a battery inside an vehicle, mount the charger to a sturdy surface or use a Ferno ICS®.

Charge Ferno batteries only with a compatible Ferno charger.

### WARNING

**Improper charging can cause injury and damage. Charge the battery only with an approved adapter and Ferno charger or compatible 36VDC Integrated Charging System (ICS).**

**Modifying the battery can cause injury and damage. Use the battery only as designed by Ferno.**

**Improper parts, modifications or items not designed for the cot can cause injury. Use only Ferno-approved parts and service. Attach only approved items to the cot. Do not modify the cot.**

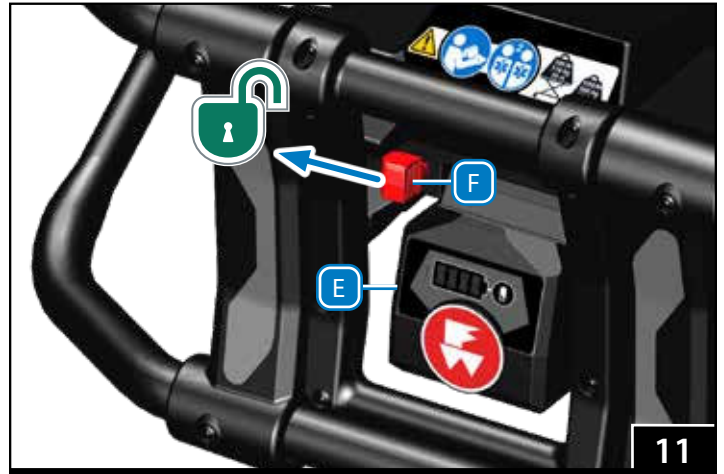

11

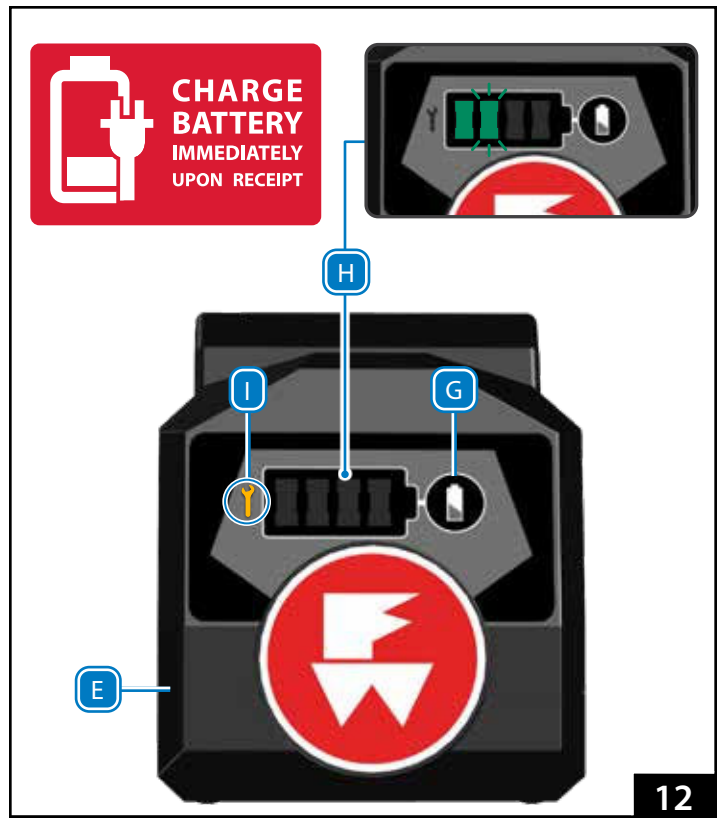

12

## 5.6 Shock Frame

The standard shock frame (J) adjusts between flat and raised (feet elevated 13°) positions (Figure 13).

The optional shock frame with knee-gatch feature (K), (Figure 15) adjusts between the flat and raised positions like the standard shock frame, and also can be adjusted to the knee-gatch position (knees elevated 30°).

Follow local medical protocols when deciding which position to use. Always work from the control end of the cot. Raising and lowering from the side can expose your hands to pinch points.

Use an underhand grip (palms up) to support the shock frame before and while raising or lowering.

### Raised Position:

- To raise: Working from the control end of the cot, use both hands to lift the shock frame until it locks automatically in the raised position (Figure 13), (J). Confirm the lock has engaged.
- To lower: Working from the control end of the cot, support the weight of the shock frame with both hands and lift slightly. With your thumbs, press both shock frame control levers (Figure 14), (L) to disengage the lock, then lower the shock frame.

### Knee-Gatch Position:

- To raise: Working from the control end of the cot, grasp the lifting strap with one hand and the foot end of the shock frame with your other hand. Lift the middle of the shock frame with the lifting strap (M) while sliding the foot end of the shock frame toward the loading end of the cot until the frame locks in the knee-gatch position (Figure 15). Confirm the lock has engaged.
- To lower: Working from the control-end of the cot, use the lifting strap (M) to lift the shock frame slightly. With your thumb, press the shock frame control lever (L) to disengage the lock (Figure 15), then lower the shock frame.

### NOTICE

A shock frame that is not locked into the support on both sides can disengage and damage the cot. Confirm that both side locks engage when placing the shock frame in a raised position.

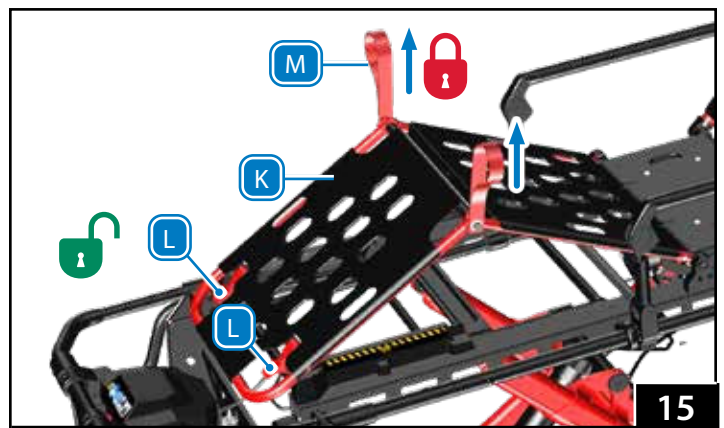
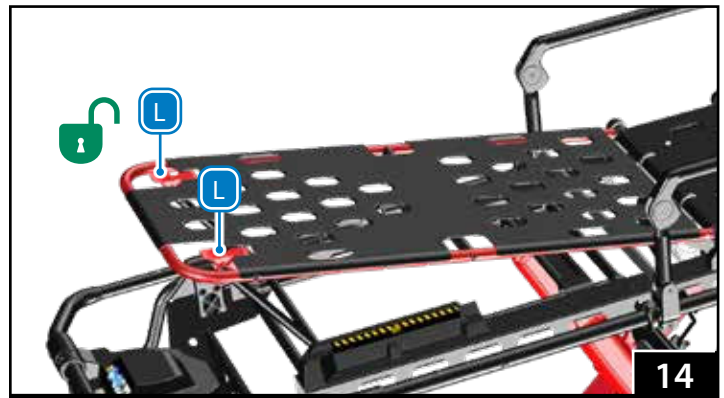
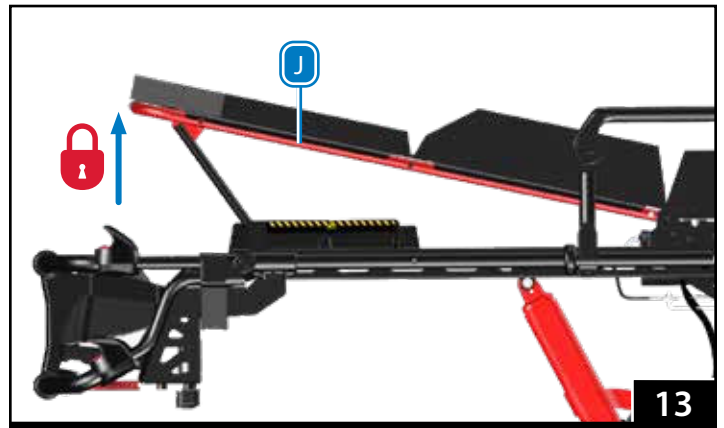

## 5.7 Backrest

The backrest (N) adjusts 0°-77° to elevate the patient's torso for comfort or medical necessity.

The gas spring is under pressure to ease raising and lowering. With a heavy patient, support the backrest while making adjustments. With a light patient, control the upward movement of the backrest so it does not move too quickly.

1. Loosen or unbuckle the restraints.
2. Working from the loading end of the cot, grasp the backrest frame (N) with both hands. Support the weight of the patient and any equipment on the backrest.
3. Squeeze either red control handle toward the backrest frame to unlock the backrest (Figure 16), then raise or lower the backrest to the desired position.
4. Release the control handle to lock the backrest.
5. Fasten and adjust the restraints.

### ⚠ WARNING

Rolling sideways or pushing by the backrest can cause the cot to tip. Roll only toward the control or operator end and grasp the main frame when rolling.

Unsecured equipment can cause injury. Remove equipment from the equipment hook before transport inside a motor vehicle and secure in an appropriate device.



## 5.8 Equipment Hook

The equipment hook (O) can hold equipment, bags, etc. weighing up to 50 lb (22 kg) with a maximum 1.21" (31.7 mm) diameter carry handle (Figure 17).

The equipment hook does not secure items during transport in an ambulance. Remove items from the equipment hook before transport.

Only use equipment that fits properly into the equipment hook.

1. Raise the backrest to access the equipment hook.
2. Set the carry handle of the equipment in the hook. Verify the equipment is stable in the hook.
3. Remove equipment from the hook prior to transport inside a motor vehicle. For transport of equipment inside a motor vehicle, secure only to a crash-stable equipment holder designed for this purpose.
4. Remove equipment from the hook before lowering the backrest.

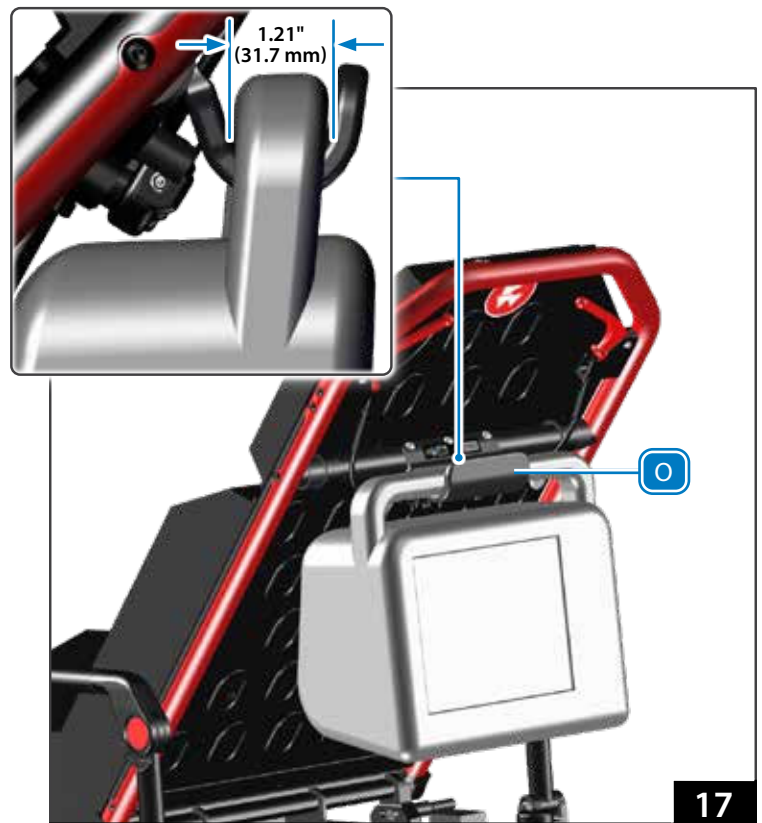

**NOTICE**

Do not use fold-down sidearms or the SX Surface Xtender to lift the cot. Grasp and lift only using the cot main frame.

**5.9 Sidearms****FOLD-DOWN SIDEARMS**

Fold-down sidearms (P) provide patient security and comfort. To lower, press the release button and lower the sidearm (Figure 18). To raise, lift the sidearm up until it locks into position.

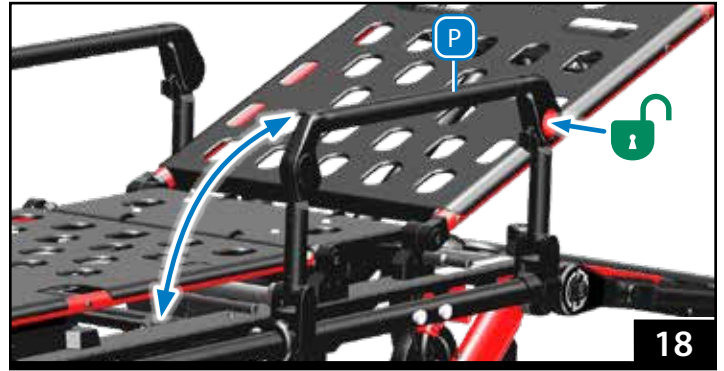
**SX SURFACE XTENDERS**

SX surface extenders provide added patient security and comfort, increase the overall width of the patient surface for large patients, and provide a location to place a patient's arm to start an IV. Each side locks individually. There are five locking positions and an unlocked, 'down' position (Figure 19).

A safety feature prevents the lock mechanism from being overloaded. If the release handle is operated while weight is on the SX, the lock will not release. Lift the SX upward to assume the weight and release the lock before lowering.

To raise, rotate the SX up to the desired position. There is no need to use the lock release.

To lower, lift the SX slightly to take the weight off the locking mechanism, then squeeze the red lock release (Figure 19) and lower the SX to the desired position.

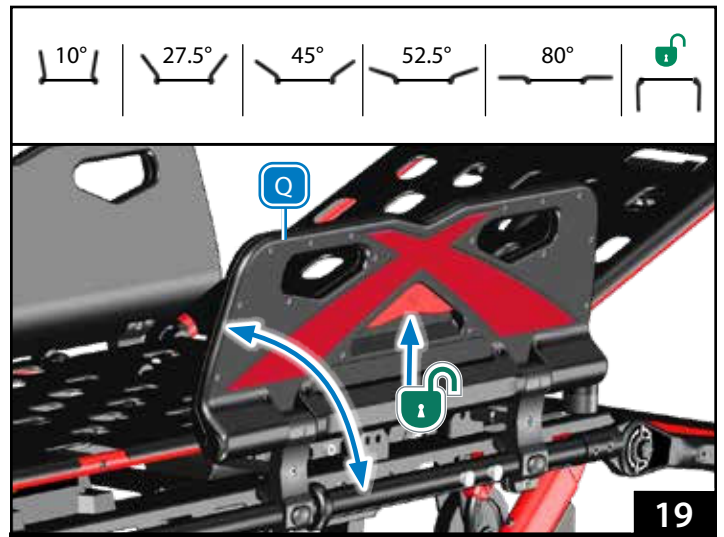
**5.10 ERGOFrame**

The ERGOFrame (R) adjusts to five positions, helps operators maintain proper ergonomic positions during lifting, and shortens the cot when space is limited (Figure 20).

Squeeze the release handle (S) to unlock, then raise or lower the frame to a new position. Let go of the release handle to allow the frame to lock. Confirm the frame has locked at the desired position. Extend the frame before fully-retracting the cot.

- **Locked Positions (4):** The frame locks in four positions (all except the folded position). These positions provide good ergonomic lifting angles for lifting or steering the cot.
- **Level/Extended Position:** Use this locked position to load the cot into, or unload it from, an ambulance.
- **Folded Position:** Use the unlocked position to shorten the cot for better maneuvering where space is limited.

**NOTICE**

Do not fully retract the cot with the ERGOFrame in a lowered position. Stop at a comfortable position, extend the ERGOFrame, then continue retracting the cot.

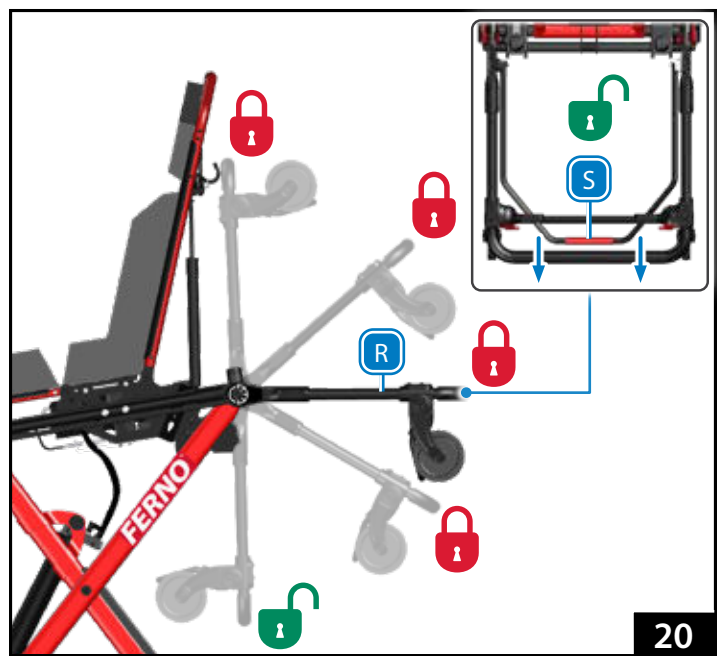

## 5.11 Safety Bar Release Levers

The safety bar (T), (Figure 21), catches the safety hook mounted in the rear of the ambulance to secure the cot inside the ambulance while the operators extend or retract the legs. Always confirm the hook catches the safety bar during every loading and unloading process.

Use the safety-bar release levers (U) to disengage the bar from the safety hook at the appropriate time.

## 5.12 Mattress

The mattress (V) is designed to provide patient security and comfort. The five hooks (X) on the mattress bottom attach to the patient surface (Figure 22). The head section slots (W) to allow the restraints to be routed over the patient's shoulders.

- **To Attach:** Raise the backrest and/or shock frame as needed. Feed each hook through a hole in the bed surface. (Figure 15).
- **To Remove:** Slide one hand under the mattress and apply upward pressure as you remove each hook from the surface with your other hand.

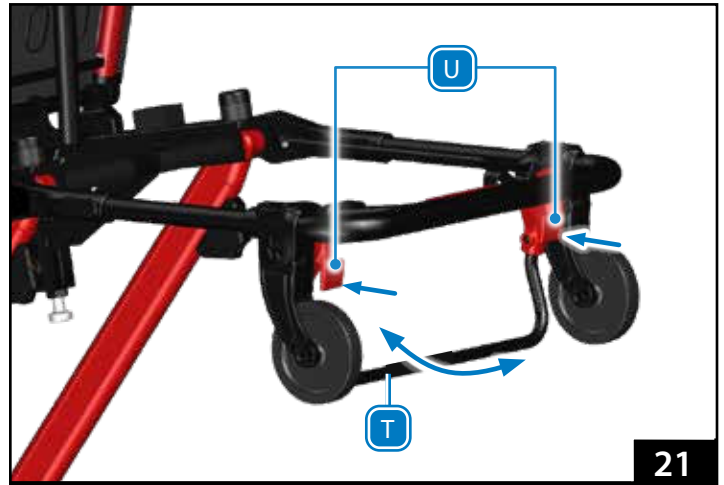

21

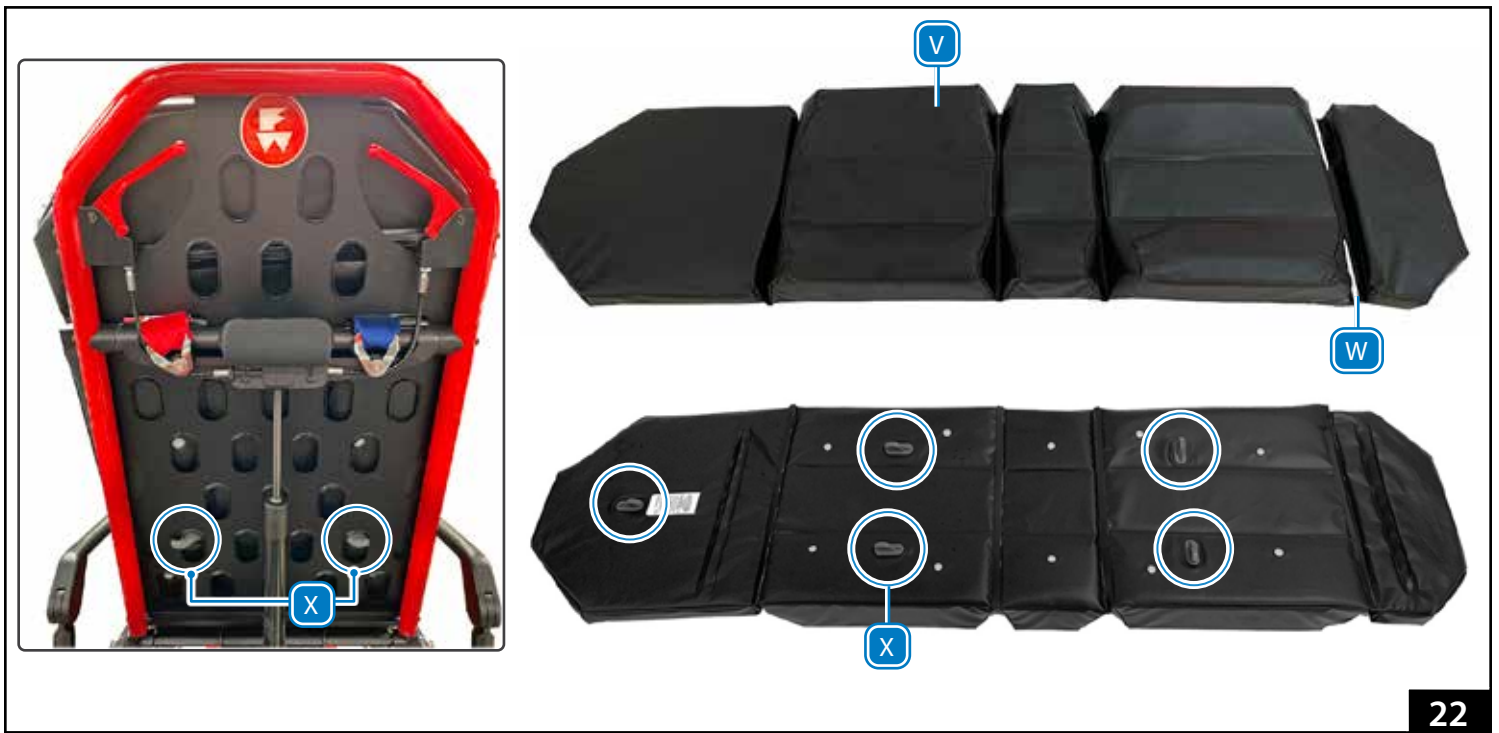

22

### 5.13 Undercarriage X-Frame

The RAPIDLIFT hydraulic system reduces extension/retraction time while extending and retracting the legs, and has a 700 lb (318 kg) load capacity. TIP RESIST integrated design provides advanced stability during rolling.

Center fastening-system posts (Y), (Figure 23) allow the cot to be secured in an SAE-compliant Ferno® PRO F1™ fastening system.

The side fastening post (Z), (Figure 24) secures the cot in a legacy antler-and-rail (non-SAE) fastening system. Control-end wheel locks are standard; loading-end directional wheel locks are optional.

### 5.14 Integrated Charging System

The Integrated Charging System (ICS®) uses power from the ambulance electrical system to automatically charge the battery while the cot is secured in a compatible fastening system.

When the cot is locked in an ICS-enabled fastening system, ICS charges the cot main battery and disables powered operation. Confirm the ICS is receiving power from the ambulance ignition, inverter, and/or outlet switch. If the battery has a very low charge, the ICS may not be able to charge the battery. Connect the battery directly to the charger separate from the ambulance and ICS.

#### NOTICE

Pressing **+** or **-** while the cot is locked in a fastening system can damage the cot and fastening system. Do not press buttons while the cot is in the fastening system. The button lockout feature is only with Ferno fastening systems with powered Integrated Charging System (optional).

Wheel locks are not a substitute for operator control. The operators must remain with the cot and keep control of it at all times. Do not leave the patient unattended. Wheel locks are not brakes. Do not use wheel locks to slow a moving cot.

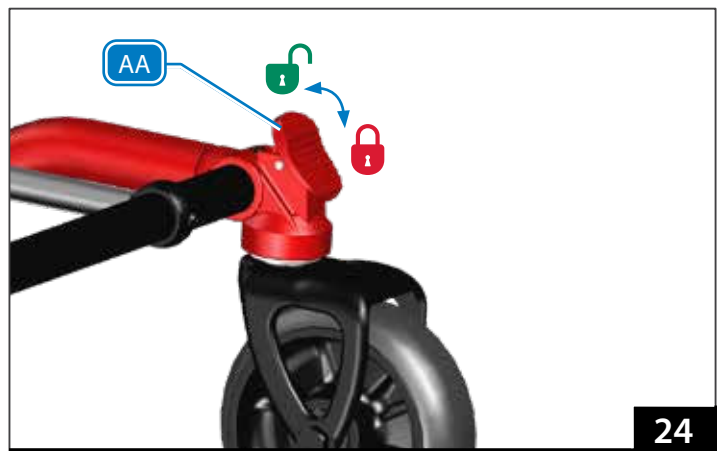

### 5.15 Wheel Locks

Control-end wheel locks (AA) help keep the cot from rolling during patient transfer and certain medical procedures. Wheel locks are on the control-end transport wheels only (Figure 24). To engage the lock, press the lever down. To unlock, press the top of the lever.

### 5.16 Directional Wheel Locks

The optional directional wheel locks (BB), (Figure 25) allow operators to lock the direction of both loading-end transport wheels in line with the length of the cot. The lock may be engaged from either side of the cot.

To lock, press down the top of the lock lever on either side of the cot. The wheels will lock automatically when they are correctly aligned using normal cot movement. To unlock, press the opposite end of the lever to allow 360° swiveling.

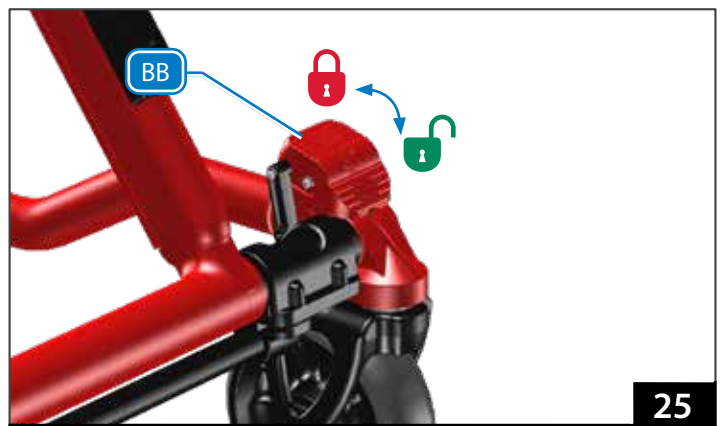

## 6 - USING THE COT

### 6.1 General Guidelines for Use

Medical advice is beyond the parameters of this manual. It is the operators' responsibility to ensure safe practices for the patient and themselves.

A minimum of two trained operators is required.

Operators must:

- Follow standard emergency patient-handling procedures when operating the cot.
- Work together and maintain control of the cot at all times. Communicate with one another and use coordinated movements to operate the cot.
- Select and use appropriate, compatible patient restraints to secure the patient on the cot. A list of compatible Ferno patient restraint systems is in the table on this page.
- Use additional trained helpers as needed (page 5).
- Stay with the patient at all times.
- Refer to the fastening system users' manual for instructions on using the fastening system.
- **Sleep Mode:** After a period of inactivity, the cot will enter Sleep Mode to conserve battery power. Press any button to wake the cot from Sleep Mode.
- Keep the cot folded when the load exceeds the standard load capacity. See "Bariatric Transport" on page 25.

### WARNING

**Use the cot only for its intended purpose. Improper use, operation, or maintenance can cause injury. Use, operate, and maintain only as instructed.**

**An unattended or unrestrained patient can be injured. Always stay with the patient and use patient restraints.**

**Rolling sideways or pushing by the backrest can cause the cot to tip. Roll only toward the control or operator end and grasp the main frame when rolling.**

**Sheets or other objects can interfere or become entangled in the cot mechanisms and cause injury or malfunction. Tuck sheets between the mattress and the patient surface. Keep restraints and other articles above the mattress.**



### Load Capacity

Inspect the cot if the load capacity has been exceeded. See page 29.

### Ferno Patient Restraint Systems (Not Supplied)

Ferno Products	Metric Patient Weight	Imperial Patient Weight
Kangoofix Neonate Transfer Aide	1.6-5 kg	3.5-11 lb
Model 676 MEDKids™ Baby Board	0.91-6.4 kg	2-15 lb
Neomate Infant Transfer Aide	2.3-6.4 kg	5-14 lb
Model 678 PediMate®	4.5-18.1 kg	10-40 lb
Model 677 MEDKids™ Pediatric Sleeve	5.4-27 kg	12-60 lb
PediMate+	4.5-45.4 kg	10-100 lb
X-Restraint system	Up to Rated Load Capacity	

## 6.2 Powered Extending/Retracting

Extending or retracting the legs with a patient on the cot requires a minimum of two trained operators who are communicating, working together, and maintaining control of the cot at all times.

Be aware that the cot automatically stops at the minimum height, user-set loading height, and at the maximum height.

Do not fully retract the legs when the ERGOFrame (R) is in a lowered position. Make the position change in two steps if needed, and allow the Loading-end Operator to adjust the ERGOFrame between steps.

1. Loading-end Operator: Adjust the ERGOFrame (R) if needed before the position change.
2. Both Operators/Trained Helpers: Keep both hands on the cot main frame. Maintain control of the cot so it does not shift when extending or retracting the legs. During the position change, move with the cot and maintain your grasp on the main frame.
3. Control-end Operator: Press any button to wake the cot from Sleep Mode, then press **+** or **-** (A) to extend or retract the legs until the cot reaches the desired height (Figure 26).

### PROVIDING LIFT ASSISTANCE

The cot load capacity is 700 lb/318 kg. Loads exceeding this limit may require lift-assistance. If the cot will not extend the legs, use additional trained helpers as needed (page 5). Operators and helpers maintain control of the cot with both hands on the main frame.

Press **+** and allow the cot to lift the load. Provide only as much lift assistance as is needed to adjust the cot height. Working together, extend the cot to the desired height.

### ⚠ WARNING

**Professional use by trained operators only. Maintain control of cot and controls. Direct helpers where to grasp to avoid pinch points. Consider terrain and use a lowered position to minimize potential to tip.**

### NOTICE

Do not fully retract the cot with the ERGOFrame in a lowered position. The mechanism can bind and jar the patient or damage the mechanism. Instead, stop at a comfortable position, extend the ERGOFrame, then continue retracting the legs.



26

## 6.3 Transferring the Patient

If the load (patient plus equipment) exceeds the load capacity, the cot legs may not extend when a button is pressed, and/or the cot may settle downward several inches. See “Providing Lift Assistance” on page 20.

1. Move the cot next to the patient and adjust it to the patient's level. If a patient is already on the cot, maneuver the cot near the destination surface.
2. Adjust cot height (A), (Figure 27), and engage wheel locks.
3. Lower or fold the sidearms.
4. Unfasten the patient restraints. Arrange the straps so they will not interfere with transferring the patient.
5. Transfer the patient onto or off from the cot using approved emergency medical procedures and local protocols.
6. Adjust the backrest, shock frame, sidearms or SX Surface Xtenders as needed.
7. Fasten and adjust the patient restraints.
8. Before moving the cot or changing its position, confirm sheets and other articles will not interfere with operation.
9. Unlock the wheel locks.
10. Raise or lower the cot to the desired height.

## 6.4 Rolling the Cot

Full 360° Movement: The cot allows full maneuverability at any height, even when fully retracted.

- Rolling the cot with a patient on it requires a minimum of two trained operators who are communicating, working together, and maintaining control of the cot at all times.
- Use additional trained helpers as needed to safely control the weight of the patient and cot (page 5).
- Before rolling, fasten and adjust the patient restraints. Press **+** or **-** to adjust the cot height (Figure 27).
- Do not roll the cot sideways or push the cot using the backrest. Roll only with both hands grasping the main frame.
- Roll on smooth, unobstructed surfaces whenever possible.
- Following local protocols, operators position themselves at the ends or sides of the cot and roll while grasping the main frame with both hands.
- If rolling the cot on a smooth, flat surface, the control-end operator may unfold and use the lead handle.
- If permitted by local protocols, one operator may roll the cot when it is not carrying a patient.
- Grasp only the cot main frame, not the lead handle, when rolling on rough surfaces or uneven terrain.

### ⚠ WARNING

**Sheets or other objects can interfere or become entangled in mechanisms and cause injury or malfunction. Tuck sheets between the mattress and the patient surface. Keep restraints and other articles above the mattress.**

**Use the cot only for its intended purpose. Improper use, operation, or maintenance can cause injury. Use, operate, and maintain only as instructed.**

**An unattended or unrestrained patient can be injured. Always stay with the patient and use patient restraints.**

**Rolling sideways or pushing by the backrest can cause the cot to tip. Roll only toward the control or operator end and grasp the main frame when rolling.**

**Professional use by trained operators only. Maintain control of cot and controls. Direct helpers where to grasp to avoid pinch points. Consider terrain and use a lowered position to minimize potential to tip.**



## 6.5 Loading the Cot

Loading the cot into an ambulance with a patient on it requires a minimum of two trained operators who are communicating, working together, and maintaining control of the cot at all times. Use additional trained helpers as needed (page 5).

1. Operators raise the ambulance folding bumper, if present.
2. Extend the ERGOFrame and roll the cot near the patient compartment door.
3. Control-End Operator: Press **+** to raise the cot to the user-set loading height. The loading wheels should be level with the ambulance floor. If not, press **+** or **-** to adjust.
4. Both Operators: Roll the cot into the patient compartment until the loading wheels are on the floor and the safety bar (T) passes the safety hook (CC). Align the cot with, and keep it parallel to, the ambulance side walls during loading.
5. Loading-End Operator: Confirm the safety bar has been captured by the safety hook (Figure 28).
6. Both Operators: Lift and hold the control end of the cot level with the ambulance floor.
7. Control-End Operator: Press and hold **-** to completely retract the cot legs (Figure 29).
8. Both Operators: Push the cot into the ambulance, keeping it parallel with the ambulance side walls and secure it in the fastening system.
9. Either Operator: Confirm the cot is secure in the fastening system. If the fastening system is equipped with ICS, confirm the ICS has disabled power and is charging the battery by checking the indicator lights on the battery.

Do not press **+** **-** buttons while the cot is inside the ambulance.

### **WARNING**

**Failure to use the safety hook (provided) can cause injury. Install and use the safety hook as described in the safety hook manual. Operators must visually confirm the safety bar on the cot is captured by the safety hook during every loading and unloading sequence.**

### **NOTICE**

If the ambulance is parked on an uneven surface, the operators may need to extend the legs higher than normal to allow the cot to roll into the ambulance.

Pressing **+** or **-** while the cot is locked in a fastening system can damage the cot and fastening system. Do not press buttons while the cot is locked in the fastening system.

The button lockout feature is only with Ferno fastening systems with powered Integrated Charging System (optional).

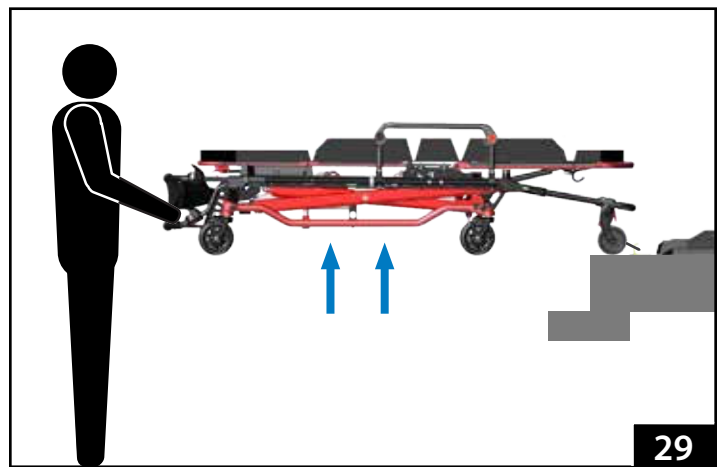
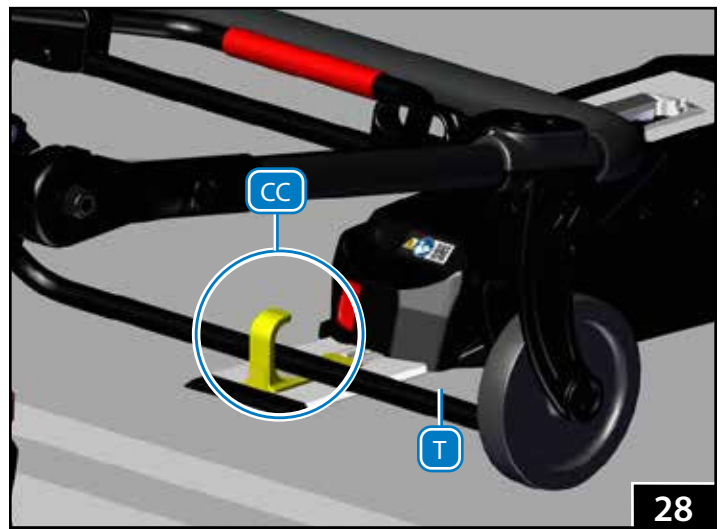

## 6.6 Unloading the Cot

Unloading the cot from an ambulance with a patient on it requires a minimum of two trained operators who are communicating, working together, and maintaining control of the cot at all times.

1. Both Operators: Raise the ambulance folding bumper if present, and release the cot from the fastening system.
  - For PRO F1, push the cot toward the front of the ambulance, then push the red release button (DD) on the fastening system.
  - For an antler-and-rail system, push the rail release handle to unlock the mechanism.
2. Control-end Operator: Grasp the lift bars and/or main frame with both hands. As you roll the cot out of the ambulance, keep the cot level with the ambulance floor and parallel with the ambulance side walls.
3. Both Operators: Guide the cot toward the safety hook (CC) and confirm the safety hook captures the safety bar (T), (Figure 30).
4. Loading-end Operator: Press and hold **+** to extend the legs.
5. Both Operators/Trained Helpers: Set the cot on the ground.
6. Loading-end Operator: Lift the safety-bar release lever to disengage the cot from the safety hook.
7. Both Operators: Roll the cot completely out of the ambulance. As the cot is rolled away from the safety hook, the Loading-End Operator may let go of the safety-bar release lever.
8. Control-End Operator: Adjust the cot height before rolling.

### WARNING

**Failure to use the safety hook (provided) can cause injury. Install and use the safety hook as described in the safety hook manual. Operators must visually confirm the safety bar on the cot is captured by the safety hook during every loading and unloading sequence.**

### NOTICE

If the ambulance is parked on an uneven surface, the operators may need to extend the legs higher than normal to allow the cot to roll into the ambulance.

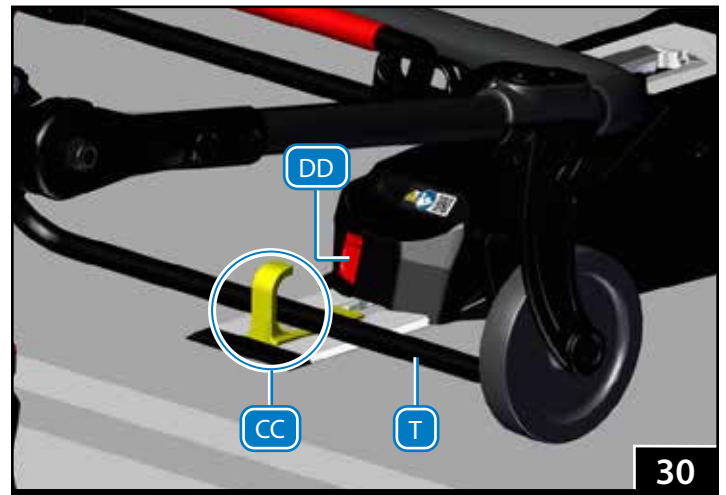

## 6.7 One Operator, Empty Cot

If local protocols permit, an empty cot (no patient) may be operated by one trained operator (Figure 31). Always use two operators when a patient is on the cot.

To adjust cot height, press **+** or **-**.

For loading and unloading, follow the procedures as for two operators. Guide the cot toward the fastening system so the safety hook will catch the center of the safety bar during loading and unloading.

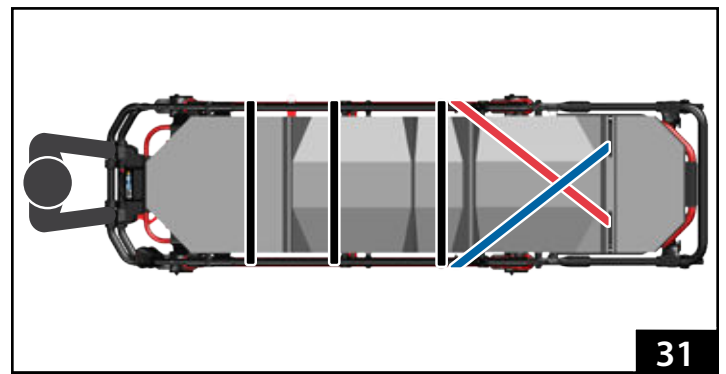

## 6.8 Manual Back-Up

When the battery charge is low or depleted, swap for a charged battery. If a charged battery is not available, use the manual back-up system to operate the cot. Use additional trained helpers as needed (page 5).

**Note:** The manual back-up handle (EE) will not function unless the weight has been lifted off the leg locking mechanism. This is a safety feature to help prevent accidental retracting of the legs.

Do not fully retract the legs when the ERGOFrame is in a lowered position. Make the position change in two steps if needed, and allow the Loading-end Operator to adjust the ERGOFrame between steps.

### EXTENDING OR RETRACTING

1. Both Operators/Trained Helpers: Stand at opposite ends of the cot and grasp the main frame with an underhand grip (palms up). The Loading-End Operator adjusts the ERGOFrame (R) as needed.
2. Both Operators/Trained Helpers: Lift the cot slightly to lift the weight off the leg locking mechanism.
3. Control-End Operator: Pull the manual back-up handle (EE), (Figure 32) only long enough to make the position change.
4. Both Operators/Trained Helpers: Together, raise or lower the cot to the desired height, then hold the cot at that position.
5. Control-End Operator: Release the manual back-up handle to lock the cot at the desired height.
6. Both Operators/Trained Helpers: Slowly lower your hands to confirm the cot has stabilized at the new position.

If the ERGOFrame mechanism binds against the floor or ground and causes the cot not to sit level, do not unlock the ERGOFrame. Together, raise the cot and make the position change in two steps, allowing the Loading-end Operator to adjust the ERGOFrame between steps.

### LOADING/UNLOADING

Follow the loading and unloading instructions in this manual, with the following differences:

1. Both Operators/Trained Helpers: Roll the cot to the safety hook and confirm the safety bar engages the hook (Figure 33 inset).
2. Both Operators/Trained Helpers: Lift the cot slightly to lift the weight off the leg locking mechanism. Hold the cot at this position until the legs fully extend or retract.
3. Loading-End Operator: Grasp the undercarriage lower frame at the "Lift Here" indicator (FF), (Figure 33).
4. Control-End Operator: Pull the manual back-up handle (EE) only long enough to make the position change.
5. Loading-End Operator: Extend or retract the undercarriage.
6. Control-End Operator: Release the manual back-up handle to lock the cot at the desired height.
7. Complete the loading or unloading procedure as described in this manual.

### NOTICE

Do not fully retract the legs with the ERGOFrame in a lowered position. The mechanism can bind and jar the patient or damage the mechanism. Instead, stop at a comfortable position, extend the ERGOFrame, then continue retracting the legs.

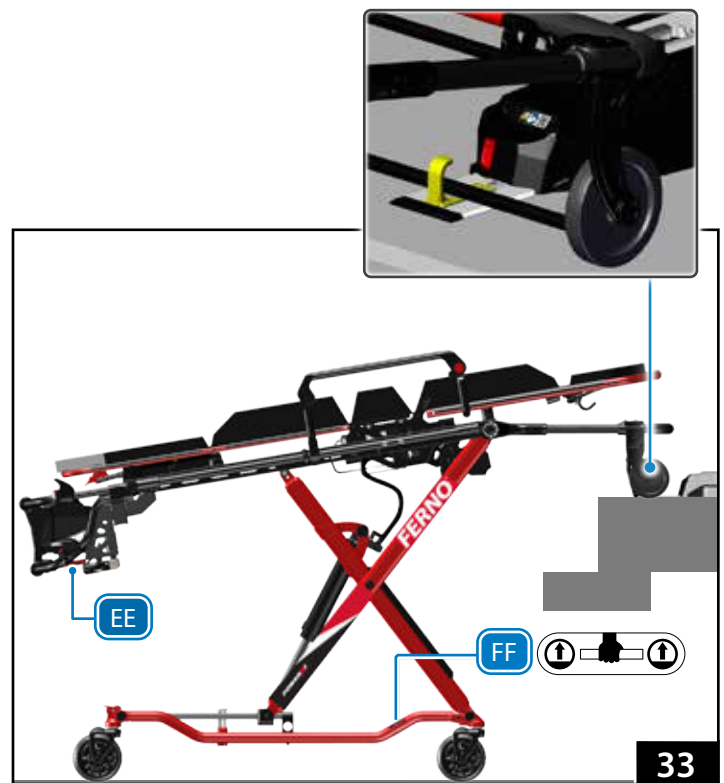

## 7 - BARIATRIC TRANSPORT

### 7.1 Bariatric Transport Definition

Ferno defines Bariatric Transport as using the cot when the standard load capacity has been exceeded.

When the load (patient plus attached equipment) exceeds the Standard Load Capacity, follow bariatric transport procedures. Inspect the cot if the standard load capacity has been exceeded (page 29).

Consider the following optional equipment (not required):

- Additional and/or longer patient restraints, or restraint extenders.
- The Ferno® LBS Jr. bariatric board provides a wider bed surface and patient restraint extenders to more easily transport an extremely large patient.
- Manta™ Rescue Aid is a large vinyl sheet with multiple handholds to aid in moving a large patient.
- Bariatric towing ring kit allow ramp and winch systems to be used.

### 7.2 Bariatric Transport Guidelines

When undertaking a bariatric transport:

- Follow your local protocols for bariatric transport.
- Use as many additional operators and trained helpers as needed to safely transport the patient (page 5).
- Follow the instructions in this manual.
- Keep the cot in the folded position when the load exceeds the standard load capacity (Figure 34).
- Use additional patient restraints, longer patient restraints, or restraint extenders approved by Ferno to properly restrain the patient.

### 7.3 Bariatric Transport: Transferring the Patient

Adapt the standard patient-transfer instructions as follows:

- Attach accessories (restraint extenders, additional and/or longer patient restraints, LBS Jr., etc.) before transferring the patient onto the cot.
- Fold the cot before transferring the patient onto the cot.
- Secure the patient on the folded cot (Figure 35).

#### WARNING

**Improper bariatric transport can cause injury to the patient, operators and helpers. Follow local protocols and the instructions in this manual. Keep the cot folded when exceeding the standard load capacity. Use as many additional operators and helpers as needed to safely transport the patient.**

#### NOTICE

Follow bariatric transport procedures when working with loads in excess of the standard load capacity. Exceeding the standard load capacity can damage the cot. Inspect the cot and patient restraints for damage if the standard load capacity has been exceeded.

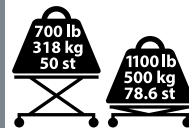

#### Load Capacity

Inspect the cot if the load capacity has been exceeded. See page 29.



34

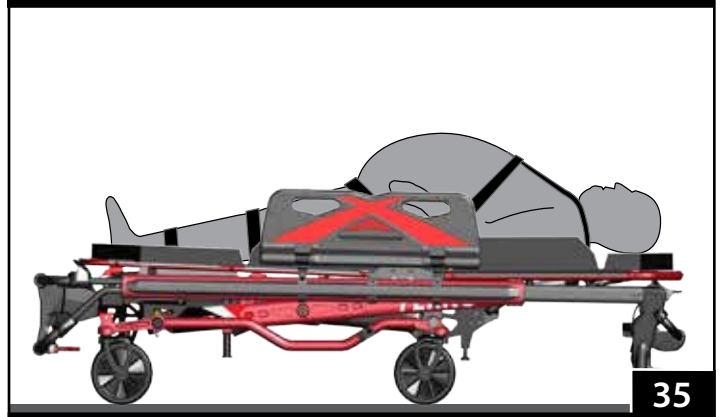

35

## 7.4 Bariatric Transport: Rolling

Roll the cot in the folded position when the load exceeds the standard load capacity.

If the patient's size and medical condition permit, raise the backrest and ERGOFrame (R). Push and steer the cot using the ERGOframe (Figure 36). Do not use the backrest to push or steer the cot.

Do not place the cot in a raised position. Rolling the cot in a raised position when the standard load capacity is exceeded can lead to injury to the patient, operators and/or trained helpers, and cot damage and/or failure.

The operators and trained helpers must lift and carry the cot over obstacles. Follow your local protocols and use additional help.



## 7.5 Bariatric Transport: Loading

To load the cot into an ambulance when the standard load capacity is being exceeded:

1. Roll the cot as close as possible to the ambulance, keeping the cot in the fully-retracted position.
2. Do not activate any controls.
3. Place one operator inside the ambulance to watch and verbally direct the operators and trained helpers to guide the cot into the fastening system (Figure 37).
4. Use additional trained helpers as needed to safely pick up the cot and place it in the ambulance.
5. Secure the cot in the fastening system.

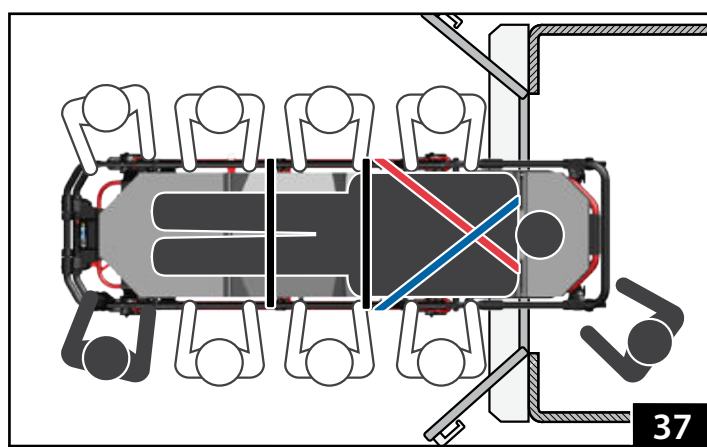

## 7.6 Bariatric Transport: Unloading

To unload the cot from an ambulance when the standard load capacity is being exceeded:

1. Do not activate any controls. Leave the cot in the fully retracted position during unloading.
2. Station one operator or helper inside the ambulance to release the cot from the safety hook when needed (Figure 37).
3. Operator: Release the cot from the fastening system.
4. Operators and Trained Helpers: Roll the cot slowly out of the ambulance, allowing the operators and trained helpers to grasp the main frame (or LBS Jr. frame). Fully support the cot throughout the move. Do not allow only the loading wheels to support the weight of the cot on the ambulance floor.
5. Inside Operator: When the safety hook catches the cot, use the release lever to release the cot.
6. Operators and Trained Helpers: Together, lift the cot out of the ambulance and set it on the ground.
7. Operators and Trained Helpers: Roll the cot on the ground as described in "Bariatric Transport: Rolling", above.

## 8 - MAINTENANCE

### 8.1 Maintenance Schedule

The cot requires regular maintenance. Set up and follow a maintenance schedule. Refer to the table for minimum intervals for maintenance. Keep maintenance records. For a sample record sheet, see “Maintenance Record” on page 35. When using maintenance products, follow the manufacturers’ directions and read the manufacturers’ material safety data sheets.

### 8.2 Service Life

Factors affecting product service life include frequency of use, local environment (temperature, humidity, etc.); maintenance (adherence to the inspection and maintenance schedule); and other factors. Follow the disinfecting, cleaning, and inspection procedures in this manual to ensure long life for the product.

### 8.3 Bloodborne Disease Notice

To reduce the risk of exposure to blood or other potentially infectious materials when using the product, follow the disinfecting and cleaning instructions in this manual.

### 8.4 Lubrication-Free

The cot is constructed with lubrication-free materials. Do not lubricate. Applying lubricant can cause damage.

Do not lubricate the upper or lower sliding actuator bearings. Clean with soap and water only. Rinse well to remove any soap residue.

### 8.5 Tracker™ (Optional)

The Tracker attaches to the cot frame and leg and counts cot cycles. A cycle is recorded each time the cot moves from the retracted position to an extended position and back. The total number of cycles is displayed on an LCD readout.

The Tracker is designed to maintain a count of the total number of cot cycles and is not designed to be reset to zero. Use the Tracker as an aid to schedule and record cot maintenance.

Part wear is partially affected by the region, temperature, and manner in which the cot is used. Conduct regular inspections. Record the number of cycles when replacing parts to develop a parts-replacement history for your service.

### 8.6 Battery Care

The battery is water-resistant and is suitable for outdoor use. Do not submerge the battery in water. Remove the battery from the cot before pressure-washing the cot. Refer to the battery users’ manual for disinfecting and cleaning instructions. Recycle the battery when it can no longer maintain a charge. Do not dispose of batteries with municipal waste. Replace a damaged or cracked battery.

#### WARNING

**Improper parts, modifications or items not designed for the cot can cause injury. Use only Ferno-approved parts and service. Attach only approved items to the cot. Do not modify the cot.**

Minimum Maintenance	Each Use or Daily	As Needed	Monthly
Daily Operator Duties (page 5)	•		
Disinfecting (page 28)	•		
Cleaning (page 28)		•	
Pressure-Washing (page 28)		•	
Inspecting (page 29)	•	•	•
Safety Bar (page 29)		•	•
Backrest Cable (page 30)		•	•

#### NOTICE

##### LUBRICATION-FREE

Lubricating parts that should not be lubricated allows dirt and foreign particles to collect on those parts, resulting in damage.



## 8.7 Disinfecting and Cleaning

Remove the mattress and restraints as needed. Refer to the restraint users' manuals to disinfect and clean restraints. Reattach mattress and restraints only when clean and dry. Inspect all items for damage while disinfecting and cleaning.



Wipe all surfaces with disinfectant. Follow the disinfectant manufacturer's instructions for application method and contact time.



Hand clean with warm water and a mild detergent. Rinse with warm, clear water. Dry with a towel or allow it to air-dry.

## 8.8 Pressure-Washing

**IP 56:** The cot has been tested in compliance with dust and water infiltration standards and has earned a Solid Particle Protection Rating of 5 (dust-protected), and Liquid Ingress Protection Rating of 6 (protected against water infiltration).

Use caution when using pressurized water, spray-wands and equipment when cleaning the cot. Wear all safety equipment recommended by the pressure-sprayer manufacturer.

Use a nozzle with a wide angle of spray (25° or 40°).

Set nozzle pressure at or below 1200 PSI (8,274 kPa) and 4 gallons per minute/15 liters per minute or less. Keep nozzle at least 18"/457 mm from the cot at all times during cleaning. If using higher pressure, increase the distance between spray wand and cot.

Reduce water pressure and increase the distance between spray-wand and cot when cleaning buttons and battery housing. Avoid spraying directly into the control-end housing or buttons.

Remove the battery from the cot. Do not pressure-wash the battery.

1. Engage the wheel locks.
2. Spray the patient surface, legs, and wheels of the cot.
3. Allow the cot to dry for 10 minutes.
4. Use a clean cloth to wipe dry the battery contacts in the control-end housing.
5. When fully dry, reattach the mattress, restraints, battery, and accessories.
6. Test cot function by fully-extending and fully-retracting it through one complete cycle.



1,200 psi  
457 mm 18"



Use lower pressure,  
increase distance



### NOTICE

Do not use disinfectants or cleaners containing phenolics or iodines. Avoid the use of bleach, as bleach can damage soft goods and can discolor the product surface.

Using abrasive cleaning compounds or applicators on the cot can cause damage. Do not use abrasive materials to clean the cot.

Do not immerse restraint metal buckles, slide bars, and clips in liquids or by washing-machine action. See the restraint users' manuals.

Lubricating parts that should not be lubricated allows dirt and foreign particles to collect on those parts, resulting in damage.

### NOTICE

The cot is water-resistant (IP56). When pressure-washing:

- Remove the battery from the cot before pressure-washing the cot.
- Do not spray water upward into the cables or forcibly at or around the control-end battery housing.
- Keep the nozzle pressure setting at 1200 PSI (8,274 kPa) or less and 4 gallons per minute/15 liters per minute or less.
- Keep the nozzle at least 18"/457 mm from the surface of the cot at all times during cleaning.
- Reduce water pressure and increase distance between spray wand and cot when cleaning buttons and control-end battery housing.

## 8.9 Inspecting the Cot

A daily inspection is recommended at the start of each operator shift, including the manual release handle and the electrical inspection on this page.

Have your service's equipment maintenance personnel inspect the cot regularly. Follow the checklists on this page and operate the cot through all its functions as described in this manual.

If inspection shows damage or excessive wear, remove the cot from service until repair is made. See "Parts and Service" on page 32.

### Daily Electrical inspection

- Do both sets of height-adjustment buttons function properly?
- Does the powered system operate properly through the full range of motion?
- Does the powered system operate smoothly, without binding or excessive noise?
- Does the actuator stop running at the user-set loading height, fully-extended and fully-retracted positions?
- Do all indicator lights on the battery function? (Push the battery check button to check the light function.)
- Is there visible sign of damage to the battery housing, battery, or battery charger?
- Does the battery attach and release properly?
- Are all cords/cables free of excessive wear, cuts, and fraying?
- Does the Integrated Charging System charge the cot battery and prevent cot operation when the cot is secured in the fastening system?

### Mechanical Inspection

- Are all components present, in good condition, and free of excessive wear?
- Does the hydraulic power system operate smoothly, without excessive noise?
- Is all hardware securely in place?
- Inspect for metal fatigue, cracks, or damage throughout the cot.
- Do all moving parts operate smoothly and properly?
- Does the cot load and unload properly?
- Does the safety hook engage the safety bar?
- Inspect the safety bar as needed, or at minimum monthly. Swing the safety bar in both directions, and confirm it returns to the neutral position within a couple of oscillations. Confirm the bar catches the safety hook during every loading and unloading sequence.
- Do the legs show signs of wear or damage?
- Does the battery-release button function properly?
- Does the manual back-up handle function properly and is the cable free of excessive play?
- Does the cot roll smoothly?
- Is the mattress ripped, punctured or damaged?
- Do the wheels show excessive wear or damage?
- Do the wheel locks and directional wheel locks engage properly and function properly?
- Are the patient restraints properly installed?
- Is patient-restraint webbing in good condition with no cuts or frayed edges?
- Are patient-restraint buckles free of visible damage and do they operate properly? Can restraint strap length be adjusted properly?
- Is the ambulance properly prepared for the cot with a Ferno-approved fastening system and safety hook installed?
- Do installed accessories operate properly without interfering with cot operation?
- Are ICS contacts clean and make a good connection?

## 8.10 Adjusting Tension of the Backrest Control Handle

The backrest control handle may require occasional adjustment to retain proper function. If the backrest lowers without operating the control handle, the cable is too tight: decrease cable tension. If the backrest does not lower when the control handle is used, or lowers too slowly, the cable is too loose: increase cable tension.

To adjust tension, follow the same procedure for each control handle (Figure 38).

1. Use a 7/16" or 11 mm wrench to loosen the jam nut (GG).
2. While using the 7/16" or 11 mm wrench to prevent jam nut (GG) from rotating, use a 5/16" or 8 mm wrench to rotate the cable nut (HH) until the control handle functions properly. As viewed from the top of the assembly (where the cable attaches to the assembly):
  - Rotate the cable nut counterclockwise to loosen or decrease the tension of the cable. (Indicated by arrow II).
  - Rotate the cable nut clockwise to tighten or increase the tension of the cable. (Indicated by arrow JJ).
3. Tighten jam nut (GG).
4. Test the backrest and confirm proper function. Repeat the steps above if further adjustment is needed. Contact Ferno if repair is needed. See "Parts and Service" on page 32.

## 8.11 Storing the Cot

If the cot will not be in service for an extended period of time, prepare it for storage as follows:

1. Lower the cot to the fully-retracted position.
2. Remove and charge the battery, then prepare it for storage. See "Storing the Battery" on page 31.

Before returning the cot to service:

1. Fully charge battery.
2. Have your service's equipment maintenance personnel inspect the cot. See "Inspecting the Cot" on page 29.

### NOTICE

Improper adjustment can damage the mechanism. Loosen the jam nut before adjusting the cable nut.

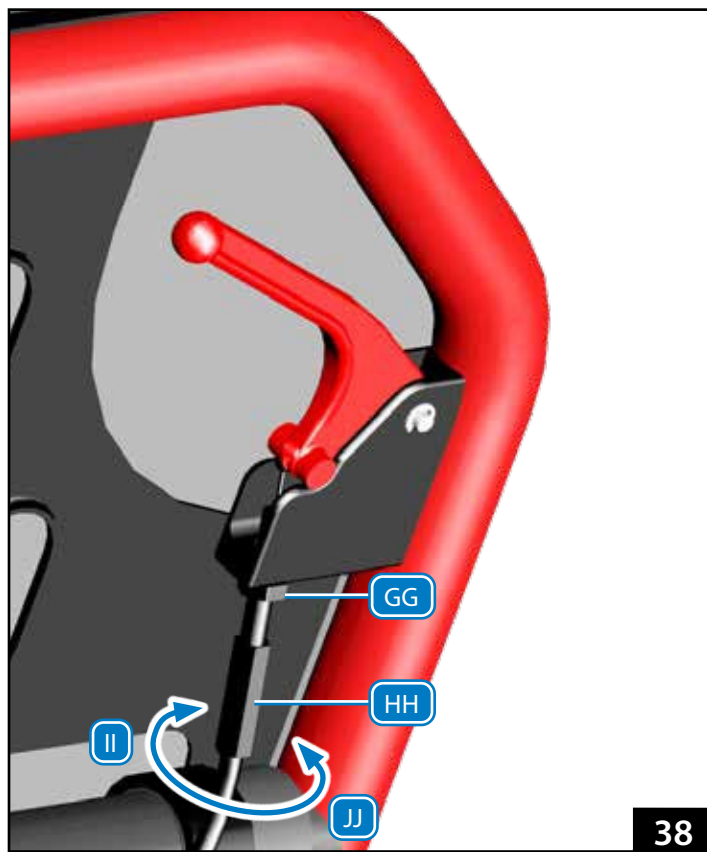

38

## 8.12 Storing the Battery

The battery's storage mode feature protects it from damage if it will not be used for a period of time. See the battery users' manual, publication 234-3689, for complete information.

- Charge the battery fully before storing it. Do not store the battery with less than a full charge.
- Maximum storage duration: 18 months.
- After a period of storage, charge the battery fully before use.
- Store the battery only indoors in a cool, dry place. Temperature Range: -40°C to 60°C; -40°F to 140°F. Do not store batteries outdoors, or where temperatures will exceed the Battery Storage Temperature range. Battery capacity can be affected if the battery is stored for long periods outside of the recommended temperature range.

### STORAGE MODE

Before storing a battery, the battery must be manually placed in storage mode. To do this, fully charge the battery, then press and hold the battery check button for 10 seconds until the wrench icon flashes and turns off.

**NOTE:** For battery revisions prior to specification shown in Figure 34, you must press and hold the battery check button for 30 seconds.

To activate the battery after storage, press the battery check button to wake it up, then charge the battery.

## 8.13 Recycling Notice

**Batteries:** Recycle batteries when they can no longer hold a charge. Do not dispose of batteries with municipal waste. Contact the government in your state, territory or country for proper recycling.

**Charger:** Recycle the charger if it becomes damaged or fails to properly charge the battery. Do not dispose of the charger with municipal waste. Contact your government for proper recycling.

### WEEE DIRECTIVE (EUROPEAN UNION)

European Union directive 2002/96/EC Waste Electrical and Electronic Equipment (WEEE) limits the disposal of electrical and electronic equipment in landfills. Contact the government in the country in which you reside for recycling information.

### U.S.A.

In the U.S.A., contact TerraCycle Regulated Waste to responsibly recycle and dispose of the Ferno ENDURCharge battery.

Visit <https://tcrwusa.com/>.

Contact the Environmental Protection Agency in your state to dispose of a damaged or nonfunctional charger.

### NOTICE

Before placing the battery in storage, charge the battery. Store only a fully-charged battery.

If the battery is deeply discharged, the ICS may not be able to charge the battery. Connect the battery directly to the charger separate from the ambulance and ICS.



39



40

### NOTICE

If the battery sustains noticeable or suspected damage or is hot to the touch, immediately remove it from service and store outside of a building.

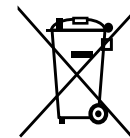

WEEE Directive

Do not dispose of batteries in municipal waste

## 9 - PARTS AND SERVICE

### 9.1 Ferno Parts and Service

For parts or professional repair, contact your Ferno distributor, Ferno Customer Relations, or visit our website for a list of Authorized Service providers.

Ferno-Washington, Inc., 70 Weil Way  
Wilmington, Ohio 45177-9371, U.S.A.

Information [www.ferno.com](http://www.ferno.com)  
Authorized Service [ferno.com/service-and-support](http://ferno.com/service-and-support)

U.S., Canada	1.877.733.0911
International	Country Code +1.937.382.1451
Fax	1.888.388.1349

### 9.2 Parts List

No.	Description	Kit
1	Mattress, POWER X1	037-4905
2	Loading Wheel	090-6035
3	Safety bar	090-6036
4	Scuff strips (set)	090-6041
5	Directional Wheel Lock (loading end)	082-2518
6	Transport Wheel	090-6031
7	Wheel lock pedal (control end)	090-6033
8	Wheel lock components (control end)	090-6034
9	Bearings, Lower	090-6039
10	Button assembly	090-6037
11	Lead handle	090-6040
12	Fold-down sidearm (pair)	159-0162
13	SX Surface Xtender Sidearm (pair)	159-0159

### WARNING

**Improper parts, modifications or items not designed for the cot can cause injury. Use only Ferno-approved parts and service. Attach only approved items to the cot. Do not modify the cot.**

**Improper charging can cause injury and damage. Charge the battery only with an approved adapter and Ferno Battery Charger or compatible 36VDC Integrated Charging System (ICS).**

**Modifying the battery can cause injury and damage. Use the battery only as designed by Ferno.**

### 9.3 Parts Diagram



## 10 - ACCESSORIES

Ferno offers a full line of accessories approved for use with the cot. Follow all instructions in accessory users' manuals. Keep the instructions with this manual.

When using accessories, be aware of any special considerations such as doorway heights and widths, or other factors which may be affected by the addition of the accessory/accessories to the cot.

Contact Ferno Customer Relations (page 2) or your Ferno distributor for product information.

Description		Part Number
Backrest pouch		037-4907
IV pole		159-0160
Mattress POWER X1		037-4926
Oxygen bottle mount, loading-end		082-2485
Oxygen bottle mount, control-end		082-2486
PacRac+ Equipment Platform		159-0161
Patient Shield		082-2097
Storage Net (load frame)		082-2482
Tracker (cycle counter)		082-2517
676 MEDKids® Baby Board	(0.91-6.4 kg / 2-15 lb)	031-3922
Kangoofix Neonate/Infant Transfer Aide	(1.6-5 kg / 3.5-11 lb)	037-4906
NeoMate Infant Transfer Aide	(2.3-6.4 kg / 5-14 lb)	031-4116
678 PediMate Child Transfer Aide	(4.5-18.1 kg / 10-40 lb)	031-3778
677 MEDKids® Pediatric Sleeve	(5.4-27 kg / 12-60 lb)	031-3923
Pedi-Mate+ Child Transfer Aide	(4.5-45.4 kg / 10-100 lb)	031-4115
Manta Bariatric Transfer Sheet	(up to rated load capacity)	038-2969
LBS Jr. Bariatric Board		082-2499
Bariatric Towing Ring		082-2511

### WARNING

**Improper parts, modifications or items not designed for the cot can cause injury. Use only Ferno-approved parts and service. Attach only approved items to the cot. Do not modify the cot.**

**Improper charging can cause injury and damage. Charge the battery only with an approved adapter and Ferno Battery Charger or compatible 36VDC Integrated Charging System (ICS).**

**Modifying the battery can cause injury and damage. Use the battery only as designed by Ferno.**

Restraints	Kit
Restraints, set, X-Restraint system	082-2489
Restraint, pelvic only, 2-piece w/brackets, black	031-4196
Restraint, shoulder only, 2-piece w/brackets, red	031-4197
Restraint, shoulder only, 2-piece w/brackets, blue	031-4198
Restraint, legs, 2-piece, black, 5' (1524 mm)	031-3892

Battery, Charger, Cables	Kit
ENDURACharge Battery, single	082-2484
AC Input charger	082-2463*
AC Wall-Mount Charger	082-2509
Charger-to-battery cable only (ENDURACharge battery)	218-3008
AC Input cord only, USA	218-3128
AC Input cord only, United Kingdom	218-3129
AC Input cord only, Europe	218-3130
AC Input cord only, Australia	218-3131

\* The charger ships with an AC-input cord and charger-to-battery connecting cables for ENDURACharge or iNjX battery, and POWERPac. When ordering, specify which AC-input cable is needed for your local AC power supply (country where the kit will be used).





70 Weil Way  
Wilmington, OH 45177

Aviation

---

Military

---

Mortuary

---

EMS

---

Rescue

---

