



iNSX®

Integrated Patient Transport & Loading System™



Read this Manual and Retain  
for Future Reference



**FERNO®**

**Instructions for Use**

September 2023  
Pub. No. 234-3622-11



# TABLE OF CONTENTS

Section	Page	Section	Page
Ferno Customer Relations _____	2	<b>5 - Using the Cot</b> _____	<b>24</b>
Unique Device Identification (UDI) _____	2	5.1 Before Placing the Cot in Service _____	24
<b>Table of Contents</b> _____	<b>3</b>	5.2 General Guidelines for Use _____	24
<b>1 - Safety Information</b> _____	<b>4</b>	5.3 One Operator, Empty Cot _____	25
1.1 Warning _____	4	5.4 Powered Extending/Retracting _____	25
1.2 Notice _____	5	5.5 Transferring the Patient _____	26
1.3 Bloodborne Disease Notice _____	5	5.6 Transferring the Patient: Chair Position _____	27
1.4 Symbol Glossary _____	5	5.7 Rolling the Cot _____	28
1.5 Safety and Instruction Labels _____	6	5.8 Loading the Cot _____	29
1.6 Compliance: USA Standard SAE J3027 _____	7	5.9 Unloading the Cot _____	30
1.7 Compliance: Worldwide _____	7	5.10 Direct Power Modes _____	31
<b>2 - Operator Focus</b> _____	<b>8</b>	5.11 Non-Powered Operation: Extending and Retracting _____	32
2.1 Operator Training _____	8	5.12 Non-Powered Operation: Loading _____	33
2.2 Operator Height and Strength _____	8	5.13 Non-Powered Operation: Unloading _____	34
2.3 Daily Operator Duties _____	8	<b>6 - Maintenance</b> _____	<b>35</b>
2.4 No-Lift Loading/Unloading _____	9	6.1 Maintenance Schedule _____	35
2.5 Control the Load _____	9	6.2 Service Life _____	35
2.6 Using Additional Help _____	10	6.3 Disinfecting /Cleaning Restraints _____	35
2.7 Terms _____	11	6.4 Disinfecting/Cleaning Mattress _____	35
<b>3 - About the Cot</b> _____	<b>12</b>	6.5 Disinfecting the Cot _____	36
3.1 Description _____	12	6.6 Cleaning the Cot _____	36
3.2 General Specifications _____	12	6.7 Pressure-Washing _____	36
<b>4 - Features</b> _____	<b>14</b>	6.8 Inspecting the Cot _____	37
4.1 Display _____	14	6.9 Lubricating the Cot _____	38
4.2 Power Switch _____	14	6.10 Storing the Cot _____	39
4.3 Lights _____	14	6.11 Storing the Battery _____	39
4.4 Display Zones _____	15	6.12 Recycling Notice _____	39
4.5 Audible Alarm _____	15	6.13 Adjusting Backrest Control Handles _____	40
4.6 Battery _____	16	6.14 Adjusting Position Indicator Lights _____	40
4.7 Battery Charger _____	17	6.15 Adjusting Manual Mode Handles _____	41
4.8 Integrated Charging System (ICS®) _____	17	6.16 Adjusting the Oxygen Cylinder Holder _____	42
4.9 Extend and Retract Buttons _____	18	<b>7 - Initial Setup</b> _____	<b>44</b>
4.10 Sleep Mode _____	18	7.1 Ambulance Information _____	44
4.11 Mode-Select Button _____	18	7.2 Accessories _____	44
4.12 Telescoping Handles _____	19	7.3 Charge and Install the Battery _____	44
4.13 Position Indicator Lights _____	19	7.4 Set the Loading Height _____	44
4.14 Shock Frame _____	19	<b>8 - Troubleshooting</b> _____	<b>45</b>
4.15 Backrest _____	20	8.1 General Troubleshooting _____	45
4.16 Safety-Bar Release Levers _____	20	8.2 Status Indicators _____	45
4.17 Wheel Locks _____	20	<b>9 - Parts and Service</b> _____	<b>46</b>
4.18 Telescoping Frame _____	21	9.1 U.S.A. and Canada _____	46
4.19 Mattress _____	21	9.2 Worldwide _____	46
4.20 Fold-Down Sidearm (Option) _____	22	<b>10 - Accessories</b> _____	<b>46</b>
4.21 SX Surface Xtender (Option) _____	22	<b>Training Record</b> _____	<b>47</b>
4.22 Non-Powered Operation (Manual Mode Handles) _____	22	<b>Maintenance Record</b> _____	<b>47</b>
4.23 Patient Restraint System _____	23		
4.24 Accessory Rail _____	23		
4.25 Oxygen Cylinder Holder _____	23		

# 1 - SAFETY INFORMATION

## 1.1 Warning

Warning safety alerts indicate a potentially hazardous situation that, if not avoided, could result in injury or death.

### WARNING

Untrained helpers can cause injury or be injured. Trained operators must operate the controls and direct helpers where to grasp the cot to avoid pinch points.

Improper use of the cot can cause injury. Use the cot only for the purpose described in this manual.

Improper operation can cause injury. Operate the cot only as described in this manual.

An unattended patient can be injured. Stay with the patient at all times.

An unrestrained patient can be injured. Use properly-installed patient restraints to secure the patient on the cot.

Rolling the cot above the factory-set maximum transport height can cause it to tip. Only roll the cot at or below the factory-set maximum transport height.

Uncontrolled movement can cause injury or damage. Support and control the cot at all times.

Sheets or other objects can interfere with, or become entangled in, the actuator or legs, which can cause injury and/or malfunction, including unexpected retracting of the cot legs. Tuck sheets between the mattress and patient surface. Keep other articles above the mattress.

Rolling the cot sideways can cause it to tip and injure the patient and/or operators. Roll the cot only toward the control end or loading end.

Pushing the cot by the backrest can cause it to tip and injure the patient and/or operators. Roll the cot only by grasping the main frame.

Trained operators must consider the environment and terrain before rolling. Rolling the cot in a lowered position will minimize the potential of a cot tip.

Failure to engage the safety hook during loading or unloading can cause injury. Operators must visually ensure each safety bar engages the safety hook and the cot is secure inside the ambulance before extending or retracting the legs.

A severe angle can injure the patient and/or operators. Control the cot when using a direct power mode.

Uncontrolled movement can cause injury or damage. Support the load before using a manual mode handle.

### WARNING

A severe angle can injure the patient and/or operators. Control the cot when operating without power.

Improper maintenance can cause injury and damage. Maintain the cot and battery only as described in this manual.

Improper adjustment of the manual mode handle cables can lead to injury. Adjust cable tension when needed.

The cot can rapidly descend and cause injury if the manual mode handles are activated while you are adjusting the cable tension. Use caution when adjusting cable tension.

Attaching improper items to the cot can cause injury. Use only Ferno-approved items on the cot.

Improper parts and service can cause injury. Use only Ferno parts and Ferno-approved service on the cot.

Modifying the cot can cause injury and damage. Use the cot only as designed by Ferno.

## 1.2 Notice

Notices emphasize important, but not hazard-related information. Failure to follow Notices could result in product or property damage.

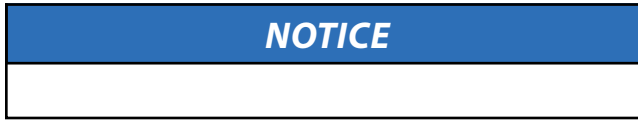

## 1.3 Bloodborne Disease Notice

To reduce the risk of exposure to blood or other potentially infectious materials when using the cot, follow the disinfecting and cleaning instructions in this manual.

## 1.4 Symbol Glossary

The symbols defined here are used on the cot and/or in this' manual. Ferno uses symbols recognized by the International Standards Organization (ISO), American National Standards Institute (ANSI) and the emergency medical services industry.

Button	Definition
	Extend Legs
	Retract Legs
	Scene Lights
	Emergency Lights
	Chair Position
	Battery Check

Symbol	Definition
	General warning of potential injury
	Laser Class 2M Warning: Do Not Stare Into Light
	Pinch point. Keep hands clear
	Read the users' manual
	Two trained operators required
	Lubricate
	Do not lubricate
	Do Not Open. No user serviceable parts.
	Do not push cot by the backrest
	Lock
	Unlock
	Load Capacity/Safe Working Load in pounds, kilograms, stone
	OFF
	ON
	Status Indicator: Low or Medium Priority
	Status Indicator: High Priority

## 1.5 Safety and Instruction Labels

Safety and instruction labels place important information from the users' manual on the cot. Read and follow label instructions. Replace worn or damaged labels immediately.

Symbol	Definition
A	General injury warning, read the users' manual, two trained operators required, load capacity
B	Ferno approved battery only
C	Do not open: no user-serviceable parts inside
D	Warning: laser emitter
E	Regulatory and ratings label
F	Warning: do not open controller or stare into laser light with optical instruments
G	Warning: do not push cot by the backrest
H	Manual release handle mount
I	Manual mode control handle
J	Warning: pinch point



A



B



C



D



E



F



G

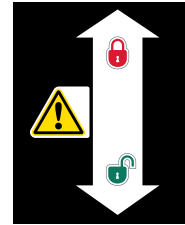

H

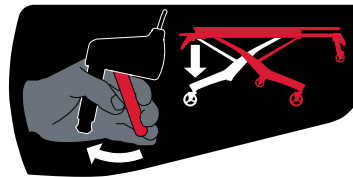

I



J

## 1.6 Compliance: USA Standard SAE J3027

The iNjX® is compatible with SAE J3027 Recommended Practice (USA), when used with a compliant fastening system (Ferno® iNjLINE®), and transport restraint system (Ferno Model 417-3 Restraint System).

## 1.7 Compliance: Worldwide

When properly installed and used with appropriate Ferno products, the iNjX meets the following standards. Standards and specifications are updated periodically. Current standards are available from these organizations.

- Alberta: Alberta Health and Wellness Ambulance Vehicle Standard Code; Section 17.5 Cot Retention System Test
- AMD: Ambulance Manufacturer's Division (AMD) of the National Truck Equipment Association Standard 004 Litter Retention System Static Test.
- AS/NZS 4535:1999: Meets the requirements of Australia/New Zealand Ambulance Restraint Systems test.
- BCAS: British Columbia Ambulance Service (BCAS) Ambulance Performance Test Criteria E2 Stretcher Retention
- CAAS: Commission on Accreditation of Ambulance Services Global Vehicle Standard (GVS)
- CE: Conforms to European standards.
- CSA: Electronic components meet Canadian Standards Association requirements.
- EN 1789 and EN 1865-3: Vehicle, fastening system, and crash-test standards.
- IEC 60601-1-2: Electrical and electromagnetic medical equipment.
- IEC 2007/47
- IP56: Ingress Protection rating. Tested in compliance with dust and water infiltration standards.
- KKK-A-1822 (F): Federal Ambulance Specification KKK-A-1822 revision F.
- MDR: Meets the requirements of the European Medical Device Regulation 2017/745.
- MDD (UK): Meets the requirements of the European Medical Device Directive 93/42/EEC.
- NFPA: National Fire Protection Association standard NFPA 1917.
- Ontario: Ontario Land Ambulance Standard, Version 5.0, Section 20.1 Main Cot Retention
- SAE J3027:2016: Society of Automotive Engineers Recommended Practice, Ambulance Litter Integrity, Retention, and Patient Restraint

## 2 - OPERATOR FOCUS

### 2.1 Operator Training

Operator using the cot:

- must read and understand this manual.
- must have training on proper use of the cot.
- must have a training on emergency-medical service and emergency patient-handling procedures.
- must have the physical ability to assist the patient.
- must practice with the cot before using it with a patient.
- must keep training records. For a sample, see page 47.

#### WARNING

**Untrained helpers can cause injury or be injured. Trained operators must operate the controls and direct helpers where to grasp the cot to avoid pinch points.**

### 2.2 Operator Height and Strength

The cot is designed to minimize the need for lifting. Whenever possible, use the powered hydraulic system to:

- Extend and retract the legs.
- Load the cot into and unload it from an ambulance.
- Transition between surfaces of varying levels.
- Place the cot at good height to establish a proper, ergonomic grasping position for the operators.

An excessive load (exceeding the 700 lb/318 kg load capacity) or non-powered operation may require the operators to lift a portion of the load. Use additional help as needed (page 10).

#### NOTICE

If the ambulance is parked on an uneven surface, the operators (and any helpers) may need to extend the legs higher than the user-set loading height to allow the cot to roll into the ambulance.

### 2.3 Daily Operator Duties

It is good practice for operators to check equipment at the start of each work shift. To check the cot prior to use, follow the procedures described in this manual:

- Unload the cot from the ambulance.
- Retract the cot to the floor or ground.
- Extend the cot to the recommended rolling height.
- Rotate the cot in a circle to verify it rolls easily.
- Visually inspect the cot for readiness (page 37).
- Load the cot into ambulance and secure it in the iNjLINE fastening system.
- If equipped, verify the cot is being charged by the ICS (page 17, or see the ICS users' manual).

## 2.4 No-Lift Loading/Unloading

The iNjLINE fastening system holds the cot level with the patient floor as the operators load it into the ambulance (Figure 1), or unload it from the ambulance (Figure 2). During the loading and unloading process:

- Do not lift the cot. Allow the legs to support the load.
- Both operators work together to guide the cot into the iNjLINE.
- The Control-end Operator confirms each cot safety bar engages the iNjLINE safety hook.
- Confirm the legs have clearance before extending or retracting. Look for obstructions such as the ambulance bumper.
- Follow the loading and unloading procedures in this manual.
- Use additional help as needed (page 10).

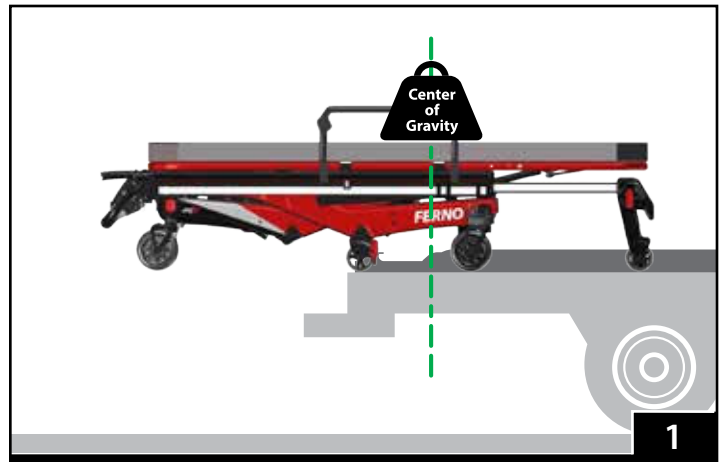

## 2.5 Control the Load

At all times during rolling, both operators (and any helpers) keep both hands on the main frame (or guide bar), support and balance the load, and maintain control of the cot. Use care on rough or uneven terrain.

Roll the cot only at, or below, the maximum transport height. This height is programmed into the cot. See "Rolling the iNjX" on page 28.

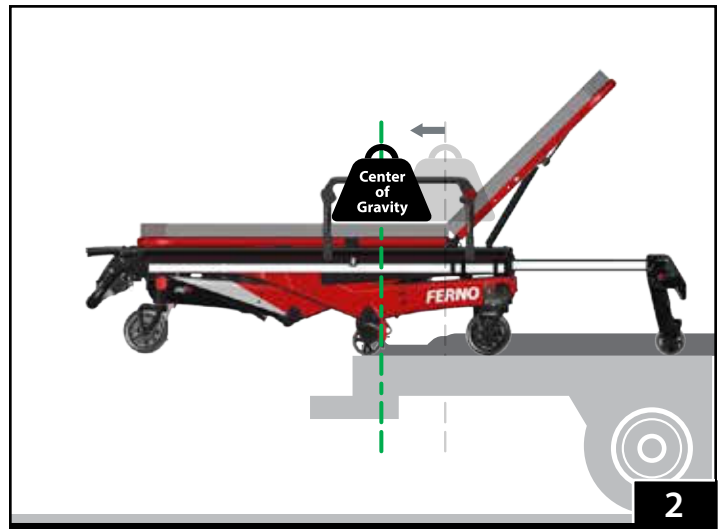

## 2.6 Using Additional Help

Operating the cot requires a minimum of two trained operators. They may need additional trained help when working with heavy loads (patient plus equipment), or when operating the cot manually.

- Two trained operators stand at the loading end and control end of the cot, maintain control of the cot, operate the controls, and direct helpers on where to stand and how to grasp the cot.
- Side helpers may need to walk sideways under some circumstances. Follow local protocols.
- Ferno recommends that helpers work in pairs to help maintain cot balance.
- For heavy loads (patient weight exceeding 95th percentile male and heavier), Ferno recommends a minimum of two trained operators and two helpers.
- Use special techniques when operating the cot without power. Refer to the non-powered operation instructions in this manual.
- Refer to the chart for suggested placement for operators and helpers.

**⚠ WARNING**

**Untrained helpers can cause injury or be injured. Trained operators must operate the controls and direct helpers where to grasp the cot to avoid pinch points.**



**700 lb  
318 kg  
50 st**

**LOAD CAPACITY**

Inspect the cot if the load capacity has been exceeded (page 37).

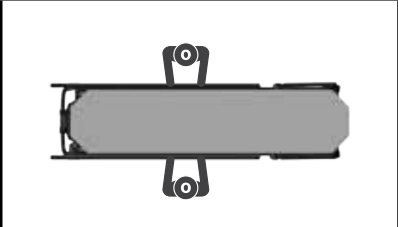
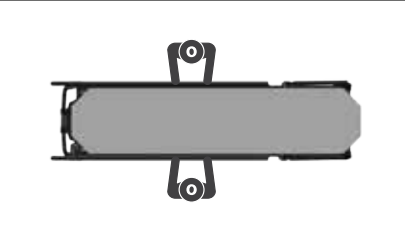
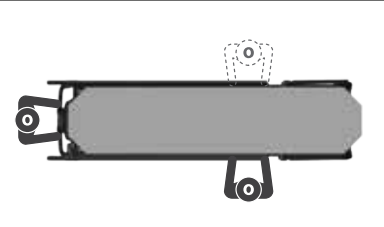
Extend/Retract	Rolling	Loading/Unloading
		

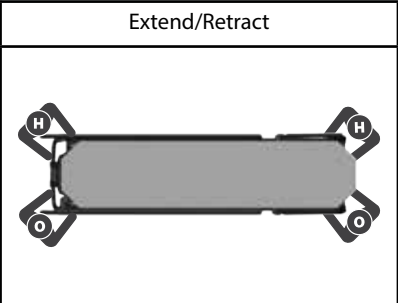
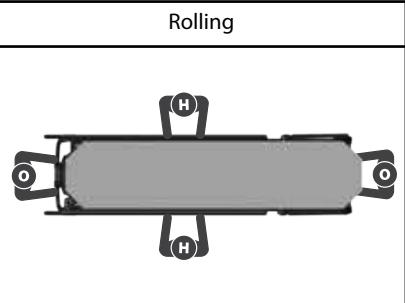
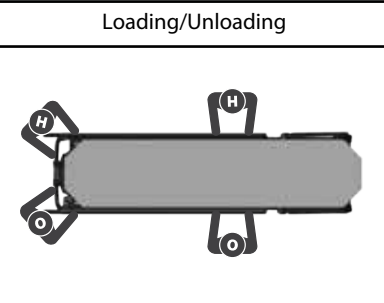
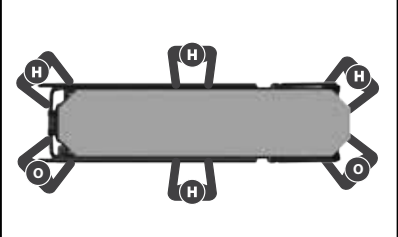
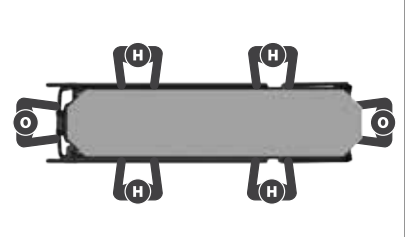
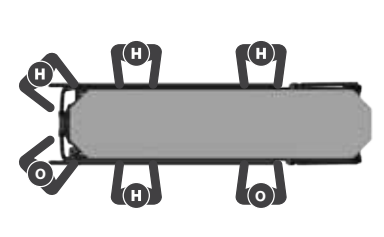
Heavy Patients (95th Percentile Male and Heavier), Ferno Recommends:		
Extend/Retract	Rolling	Loading/Unloading
		
		

Key: O = Operator H = Helper

## 2.7 Terms

- **ACTUATOR:** The actuator is a hydraulic system that extends and retracts the cot legs. One actuator is attached to each set of legs.
- **AUTO-EQUALIZE:** During normal operation, if the legs are not equally extended, pressing **+** or **-** will extend or retract one set of legs until both sets of legs are equally extended. Then, both sets of legs extend or retract simultaneously.
- **AUTOMATIC STOPS:** The cot stops automatically at the maximum safe transport height (factory-set) and at the loading height (user-set). To continue extending or retracting, press **+** or **-** again.
- **CONTROL END:** The end of the cot with the display, telescoping handles and shock frame, also known as the foot end.
- **DISPLAY:** The display provides operators with the status of many cot systems, including the legs, patient surface, battery charge, and alternate operating modes. See “Display Zones” on page 15.
- **DRIVE LIGHTS:** Drive lights are white lights on the actuators that illuminate the ground around the wheels and increase cot visibility in low light. See page 14.
- **EXTEND (LEGS):** Powered cot operation to raise the patient surface away from the transport wheels. Extend the legs to increase the height of the patient surface, or to unload the cot from an ambulance.
- **GUIDE BAR:** The control-end operator uses the guide bar to roll and maintain control of the cot. The display is mounted between the guide bar and the patient surface. A set of **+**/**-** buttons is attached to the right-hand side.
- **iNjLINE:** The iNjLINE fastening system is a Ferno fastening system designed to secure the cot in a ground-based ambulance.
- **ICS® (Integrated Charging System):** The ICS allows the cot to be charged each time it is secured in the iNjLINE. (Power to the ICS from the ambulance inverter or shore power must be ON). The ICS helps keep the cot battery fully charged.
- **LIFT-ASSIST:** Under extreme weight conditions (loads), the operators may need to provide lift-assistance. Use additional help as needed (page 10).
- **LOAD:** The overall weight of patient plus equipment placed on, or attached to, the cot.
- **LOADING END:** The end of the cot with the backrest, telescoping frame and one of two safety bars, also known as the head end.
- **LOADING HEIGHT:** Users can program the cot to stop at the normal loading height for a designated ambulance (page 44). Extend the cot to the loading height only to load it into an ambulance or unload it from an ambulance.
- **OPERATORS:** Trained operators are referred to as the Control-end Operator and Loading-end Operator. Trained operators maintain control of the cot, operate the controls, and direct helpers.
- **RETRACT (LEGS):** Powered cot operation to lower the patient surface toward the transport wheels. Retract the legs to reduce the height of the patient surface, or to load the cot into an ambulance.
- **SURROUND LIGHTS:** Red and white lights on each side of the cot that provide steady light to illuminate the cot, or flash in an attention-grabbing alert pattern to increase safety. See “Lights” on page 14.
- **TELESCOPING HANDLES:** Telescoping handles extend or retract to provide the control-end operator with additional ergonomic positions to grasp and guide the cot. A set of **+**/**-** buttons is attached to the right-hand telescoping handle (page 19).
- **TRANSPORT HEIGHT:** An alarm beeps when the patient surface is higher than the recommended maximum transport height. Keep the cot at or below this height when rolling it.
- **SHEETS:** Sheets or other articles that are placed, or find their way, beneath the patient surface can become caught in the power system. Do not tuck sheets or place other objects where they can interfere with, or become entangled in, the locking mechanism.

## 3 - ABOUT THE COT

### 3.1 Description

The Ferno® iNjX® Integrated Patient Transport & Loading System™ (“cot”) is an emergency patient-handling device designed to transport a patient over various terrain, to be loaded into and unloaded from an ambulance, and for transport inside a ground-based ambulance.

The cot is designed for use with the for Ferno® iNjLINE® series fastening system. The cot is for professional use by a minimum of two trained operators. It is designed to help reduce the risk of back injury to medical service personnel by eliminating or minimizing the amount of lifting required to extend or retract the legs.

During powered operation, no lifting is required to raise or lower the cot, or to load the cot into an ambulance or unload it from an ambulance. The cot may be operated manually when desired.

#### INCLUDED

- Ferno battery charger and adapter cable
- iNjX battery
- Sealed vinyl mattress polyurethane foam pad interior
- Set of patient restraints
- Users’ manual and training DVD
- ICS® charging contacts standard

#### FEATURES

- 700 lb/318 kg lifting capacity (load capacity)
- Independent-leg, powered transport loading system
- Legs auto-equalize before extending or retracting
- Safety Lighting System
- Variable height adjustment allows level loading into an ambulance with a floor of up to 35" (889 mm)
- User-set loading height (maximum 35"/892 mm)
- IP 56 (Ingress Protection) rating for dust, water
- 36-Volt DC power system with dual actuators
- Multifunction display
- Position-indicator lights
- Simple  operation
- Directional wheel locks (loading-end) standard
- Sidearm (SX® or fold-down option)
- Telescoping handles (control end)
- Coated handling surfaces keep hands/clothes clean
- 4 swivel transport wheels, 6" (152 mm)
- 2 wheel locks
- Pneumatic backrest
- 3-position telescoping load-end frame
- 2-position shock frame
- Direct power and non-powered backup systems



#### WARNING

**Improper use of the cot can cause injury. Use the cot only for the purpose described in this manual.**

### 3.2 General Specifications

Specifications are shown in the tables at right. General specifications are rounded. Metric conversions are calculated before rounding the Imperial measurement.

Ferno reserves the right to change specifications without notice. For more information, contact Ferno Customer Relations or your Ferno distributor (page 2).

- Height is the distance from the ground to the patient surface.
- Loading Height is the distance from the ground to the bottom of the loading wheels.
- Weight includes the battery but is without mattress, patient restraints and optional features.
- All Ferno mattresses for emergency medical service use are fully-sealed.



Dimensions	Imperial	Metric
A) Wheels	6" x 2"	153 mm x 52 mm
B) Length (Adjustable)	63" – 81"	1594-2045 mm
C) Width (Overall)	24"	597 mm
D) Width (Patient Surface)	16"	406 mm
E) Height (Adjustable)	14" – 49"	356-1245 mm
F) Maximum Transport height (Factory-Preset, measurement is to patient surface)	34"	864 mm
G) Loading Height (Adjustable, measurement is to bottom of loading wheel)	35" Maximum	889 mm Maximum
H) Backrest Adjustment	0°–76°	
I) Shock Frame Adjustment	0°–16°	

Weight	
With SX® Sidearms	214 lbs/97 kg
With Fold-Down Sidearms	203 lbs/92 kg

Load Capacity	
Imperial/Metric	700 lbs/318 kg
Stone (UK)	50 st

Power System	
Operating Temp.	-40°F to 131°F (-40°C to 55°C)
Battery Output	36 Volts DC
Charging Time (1 transport, charge maintained by ICS®)	As little as 15 minutes
Charging Time (depleted)	Up to 1 hour, 45 minutes
Charger Input	100 – 240 Volts AC
Charger Output	Up to 39.6 Volts DC, 2 Amps (for cot LiFePO4 battery)

Construction	
Frame	Aluminum
Legs	Carbon-Fiber Composite
Bed Surface	Aluminum
Wheels	Stainless steel, sealed bearings; Nonconductive wheels
Position Indicator Lights	Class 2M Laser

Soft Goods	
Mattress	72.5"x16.5"x3"/1842x419x73 mm

## 4 - FEATURES

### 4.1 Display

The display screen inner surface is coated with a layer to protect it against ultraviolet (UV) light and pressure damage. This clear surface is normally invisible but may sometimes be seen as lines of clear “dots” when viewed at an angle. This is normal.

Features include:

- (A) Power switch (right side)
- (B) Manual mode button (left side)
- (C) Scene lights button
- (D) Emergency lights button
- (E) Chair position button
- (F) Battery check button
- (G) Display screen

### 4.2 Power Switch

The power switch (A, Figure 3) is located on the right side of the display. Keep the switch in the ON (I) position for all cot operations.

If the cot will not be used for more than 30 minutes, turn the power switch OFF (O) to conserve battery power.

After 10 minutes of non-use, the cot will enter Sleep Mode to conserve power. See “Sleep Mode” on page 18.

A powered Integrated Charging System (ICS, page 17) will disable the cot powered mode and charge the battery when the cot is locked in the fastening system.

### 4.3 Lights

The safety lighting system (Figure 4) features two types of lights that illuminate the cot and surrounding area to increase operator and patient safety. Both types are ON or OFF at the same time.

- Drive Lights (H) are affixed to each actuator and provide steady light to illuminate the ground around the cot.
- Surround Lights (I) are white and red bar lights that span the length of each side of the cot to increase cot visibility. These lights can flash or provide steady light.

Use one of two buttons to turn the lights ON and OFF. An LED in the upper-right corner of the button indicates the active light mode. Lights also turn OFF when the cot enters Sleep Mode. See “Sleep Mode” on page 18.

For steady “Scene Lighting” press the far-left display button (C, Figure 3). The drive lights and surround lights illuminate with steady white light. Press the button again to turn all lights OFF.

For flashing Emergency Lights, press the center-left button on the display (D, Figure 3). The drive lights remain steady ON, but the surround lights will illuminate and flash in a sequence of red-red-white. Press the button again to turn all lights OFF.

### NOTICE

Turn the power OFF when the cot will not be in use. See “Storing the Cot” on page 39.

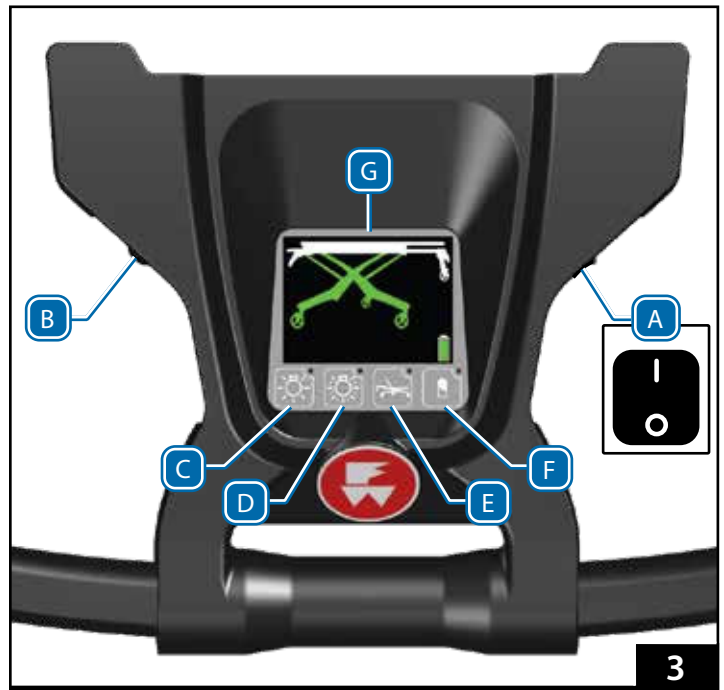

## 4.4 Display Zones

Turning the power switch ON (I) (A, Figure 3 on page 14) illuminates the display and prepares the cot for its default, powered operating mode. The display is off when the power switch is OFF (O) or when the cot enters Sleep Mode. To awaken from Sleep Mode, press . See “Sleep Mode” on page 18.

The display shows the following information (Figure 5):

- **COT:** The cot is displayed in various colors to indicate the current status of each area. Refer to the table at right.
- **TIMER:** The countdown timer appears in the lower-left corner of the display only when the cot is in a direct power mode. See “Direct Power Modes” on page 31. If the countdown timer is allowed to expire, the cot returns to its default powered mode.
- **STATUS:** This bottom center of the display illuminates with notices and safety information. Based on the condition, a warning triangle, other symbol, and/or alphanumeric code may be displayed. The warning triangle is yellow for medium-level notices, and red for high-priority notices (Figure 5). See “Audible Alarm” below and “Status Indicators” on page 45.
- **BATTERY:** The symbol indicates the current battery charge. It is illuminated whenever the cot power is ON or the cot is connected to a powered ICS. The color and shape of the battery indicator shows the approximate charge remaining in the battery. Refer to the table at right.

### NOTICE

The cot beeps when a status indicator is displayed. The severity of the status determines the number of beeps.

## 4.5 Audible Alarm

The cot will sound a series of beeps when a status indicator is displayed. The number of beeps is dependent on the severity of the situation. The alarm continues to sound until the status returns to normal.

- High-priority: 2+3 beeps, pause, repeat
- Medium-priority: 2 beeps/15 seconds
- Low-priority: 1 beep/minute

### Cot Color Indicators

LEG	
Green	Legs may be extended or retracted
White	Legs will not extend or retract
Blue	Direct Power: blue legs move when a button is pressed
PATIENT SURFACE	
White	Safe transport height
Yellow/Red	Above max transport height. Lower before rolling.
WHEELS	
Green/White	Cot may be rolled if patient surface is at a suitable transport height
Red	Do not roll the cot

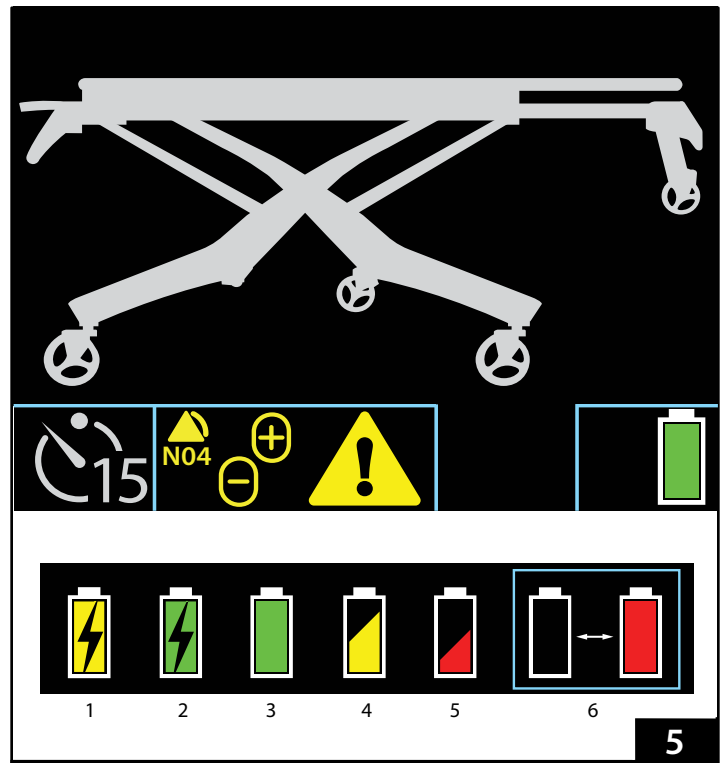

Symbol	Definition
1	Connected to ICS, charging
2	Connected to ICS, charge full
3	Full charge
4	Moderate charge
5	Low charge
6	Battery Depleted (flash red/outline)

## 4.6 Battery

The iNFX battery (J, Figure 6) is a rechargeable, 36 Volt DC lithium-iron phosphate battery (LiFePO<sub>4</sub>). The battery has a carry handle (K). The battery installs under the shock frame, behind the display (Figure 7).

For complete use, maintenance, and safety information, refer to Ferno publication 234-3595.

- Charge the battery by securing the cot in a fastening system with powered ICS, or remove the battery from the cot and connect it directly to a Ferno battery charger.
- Charging time is 15 minutes (one transport, maintaining the charge with ICS) to 1 hour, 45 minutes (depleted battery). If a battery has a very low charge, extend the charging time.
- Actual charging time varies based on frequency of recharge, depth of discharge, and battery age. Patient weight and extreme temperature can also affect the power available from each battery charge.
- Turn the power OFF if the cot will not be used for more than 30 minutes.
- The battery is water-resistant and is suitable for outdoor use. Do not submerge the battery in water.
- Before placing the battery in storage, charge it. Store only a fully-charged battery. See page 39.
- Replace a damaged or cracked battery. Do not open the sealed battery case. Do not dismantle, open or shred the battery.
- Recycle the battery when it no longer holds a charge (page 39).

### REMOVING THE BATTERY

1. Turn the power switch OFF (A, Figure 3, page 14).
2. Raise the shock frame.
3. Place your thumbs under the front corners of the battery cover and lift to remove.
4. Grasp only the battery-cable plug (L, Figure 7) to disconnect the cable from the battery. Do not pull on the cable.
5. Use the battery carry handle to lift the battery out of the cradle.

### ATTACHING THE BATTERY

6. Confirm the power switch is OFF.
7. Raise the shock frame.
8. Place your thumbs under the front corners of the battery cover and lift to remove.
9. Angle and slide the battery into the cradle. Press down to lock the battery in place in the cradle.
10. Connect the battery cable (L, Figure 7) to the battery port.
11. Insert the front tabs of the battery cover into the slots and then press down the area near the display to snap the cover into place.
12. Lower the shock frame.



6

### NOTICE

If the battery sustains noticeable or suspected damage or is hot to the touch, immediately remove it from service and store outside of a building.



7

## 4.7 Battery Charger

Use only the provided Ferno battery charger (M, Figure 8) to charge Ferno batteries, and charge only Ferno batteries with the charger. For complete use, maintenance, and safety information, refer to Ferno publication 234-3588.

The charger output cable connects to an ICS. An adapter cable (N, supplied) allows the charger to connect directly to the cot battery. The charger has two indicator lights (red and green).

To charge the battery, see “Battery” on page 16 and “Integrated Charging System” below.

### Charger Light Indicators

Red light (3x slow flash)	Initial power on. Battery disconnected/not detected.
No lights (connected to power)	Standby/Ready
Red light (solid)	Charging
Green light (slow flash)	Charging (very low charge)
Green light (solid)	Charging complete
Alternating Red/Green (slow)	Battery fault
Green light (fast flash)	Charger fault (over voltage)
Red and Green lights slow flash for 30 seconds	Short circuit protection activated. Check the charger output cable, battery adapter cable, or ICS.

Older units:

Slow flash 3x red, 1x green

**Fast flash:** the light flashes 10 times per second.

**Slow flash:** the light flashes once per second.

### NOTICE

When inside an ambulance, connect the cot and charger only to an ICS. Cables can create a trip hazard, and cables can be damaged when the cot is moved.

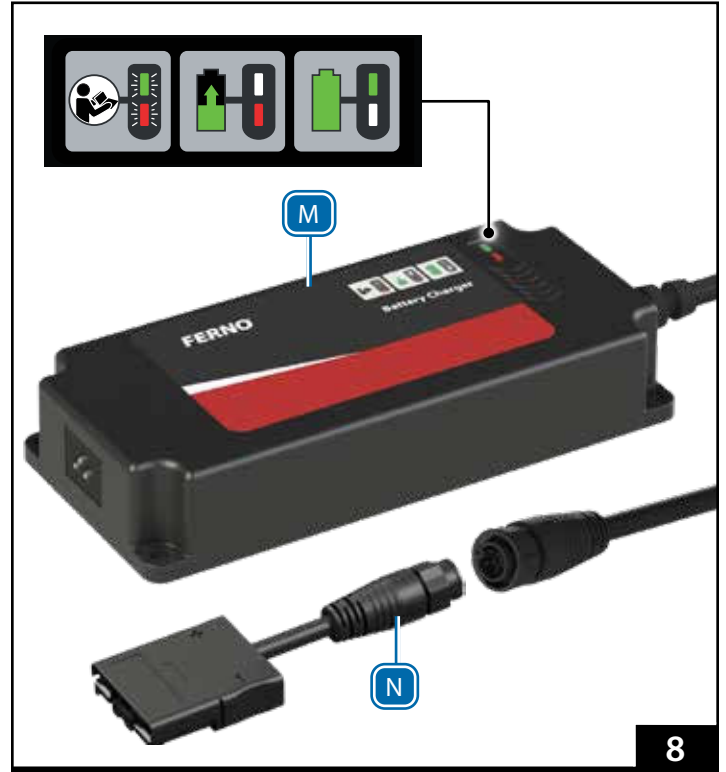

8

## 4.8 Integrated Charging System (ICS®)

To charge a battery inside an ambulance, the Ferno ICS and iNLINE fastening system must be used.



When the cot is locked in the fastening system (Figure 9), ICS charges the cot main battery and disables powered operation. Confirm the ICS is receiving power from the ambulance ignition, inverter, and/or outlet switch.

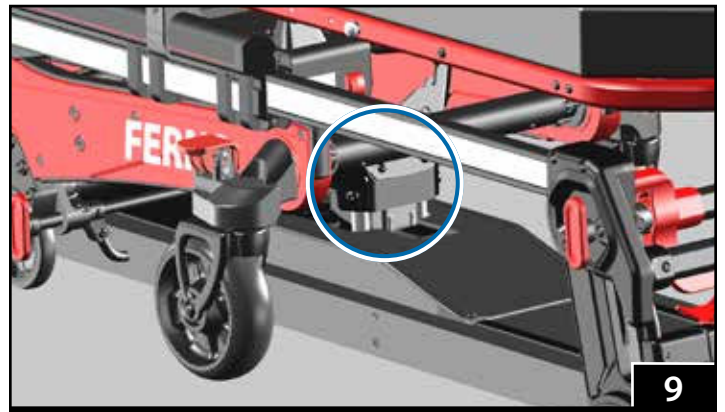

If the battery has a very low charge, the ICS may not be able to charge the battery. Connect the battery directly to the charger separate from the ambulance and ICS.





9

## 4.9 Extend and Retract Buttons



Extend  and Retract  buttons (O, Figure 10) are affixed to the control-end telescoping handle and guide bar. Button function is identical.

To activate the cot after turning the power switch ON, or to wake the cot from Sleep Mode, press . Note: only  activates the cot.

If the patient surface is not level when beginning to extend or retract, the legs automatically equalize before extending or retracting together.

During the loading (page 29) and unloading process (page 30) when the cot is supported by the ambulance floor, pressing  or  will extend or retract only one set of legs at a time.

### AUTOMATIC STOPS

The cot stops automatically at up to four heights: fully-lowered, fully-raised, recommended transport height (factory-set), and the user-set loading height. When the cot stops at the transport or user-set loading height, press  or  again to continue extending or retracting the legs.

The cot stops at the user-set loading height only when extending. To set the loading height, see page 44.



10

## 4.10 Sleep Mode

Sleep Mode conserves battery power. If the cot is not in use for more than 10 minutes (no buttons pressed), the system enters Sleep Mode. In Sleep Mode, the display and all lights are OFF.

The indicator light in the battery check button (F, Figure 11) will flash every 4 seconds when the cot is in Sleep Mode.

Press the battery check button or  or  button to activate the cot.

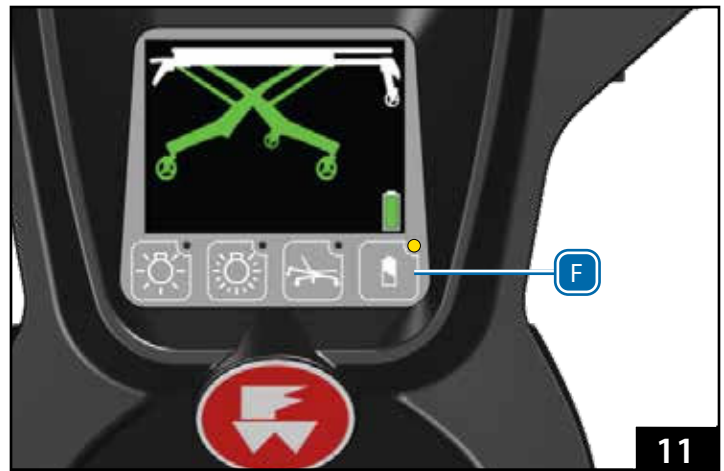

11

## 4.11 Mode-Select Button

Press the mode-select button (B, Figure 12) to cycle between direct power modes and the set-loading height feature. Direct power modes are rarely used. See page 31.

Each button press cycles to the next mode, with matching images on the display. The button-press sequence is:

- Direct power both legs
- Direct power loading-end legs only
- Direct power control-end legs only
- Set loading height. See "Set the Loading Height" on page 44.
- Standard operating mode

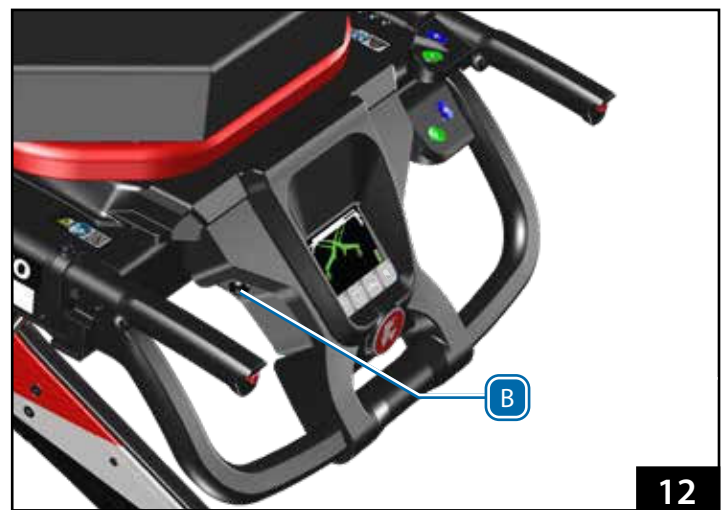

12

## 4.12 Telescoping Handles

Telescoping handles (P, Figure 13) lock in two positions: fully retracted and extended (about 9"/225 mm). Use the telescoping handles only when they are in a locked position. To change the handle position:

1. Press the red button on the end of the handle (Figure 13) and push or pull the handle to the desired position.
2. Release the button. Push or pull the handle to verify it has locked.



13

## 4.13 Position Indicator Lights

Position indicator lights (Q, Figure 14) project a red line on the ambulance floor as a visual aid for the operators. The lights have no effect on cot operation.

Position indicator lights activate automatically during the loading and unloading process and help operators visually locate the proper position to stop rolling the cot and extend or retract the control-end legs.

The red line shows the approximate position of the intermediate loading wheels. If the line is visible on the ambulance floor, then the intermediate loading wheels and the majority of the load (the weight on the cot) are also inside the ambulance.



14

## 4.14 Shock Frame

The shock frame (R, Figure 15) elevates the patient's feet approximately 16°. Follow your local medical protocols when deciding to use the shock frame. Use an underhand grip (palms up) to support the shock frame when raising or lowering it. For proper, ergonomically-correct operation, always work from the control end of the cot.

To raise the shock frame:

1. Unfasten or loosen the leg restraint.
2. Lift the shock frame with both hands until it locks in the raised position. The support bars engage automatically.
3. Fasten and adjust the leg restraint.

To lower the shock frame:

1. Unfasten or loosen the leg restraint.
2. Support the weight of the shock frame with both hands and lift slightly.
3. Using both thumbs, press the shock frame control levers (S, Figure 16) to disengage the support bars, then lower the shock frame.
4. Fasten and adjust the leg restraint.

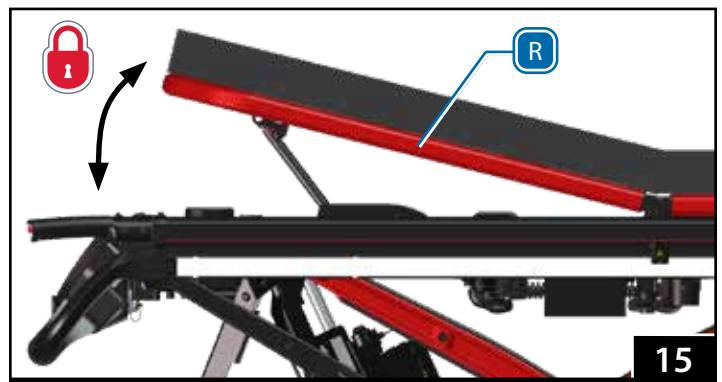

15

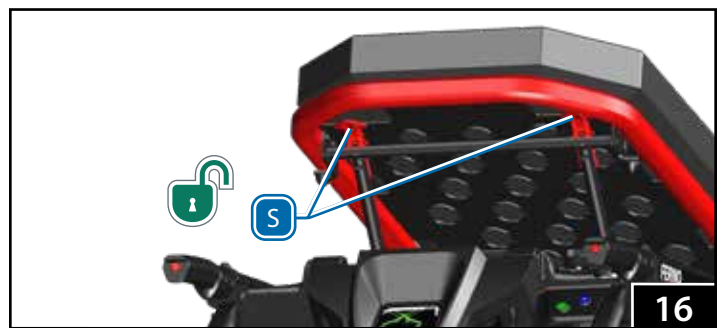

16

## 4.15 Backrest

The backrest (T, Figure 17) adjusts between 0° and 76° to elevate the patient's torso for patient comfort or medical necessity.

The gas spring is under pressure to ease raising and lowering. With a heavy patient, support the patient's weight before adjusting the backrest. With a light patient, control the upward movement of the backrest so it does not move too quickly.

To adjust the backrest:

1. Loosen or unbuckle the restraints.
2. Lower the sidearms. See "Fold-Down Sidearm" or "SX Surface Xtender (Option)" on page 22.
3. Support the weight of the backrest and patient before using a control handle.
4. Squeeze either red control handle toward the backrest frame to unlock the backrest (U, Figure 17).
5. Raise or lower the backrest to the desired position, then release the control handle to lock the backrest.
6. Adjust the sidearms as needed for patient comfort.
7. Adjust and fasten the patient restraints.

### NOTICE

Do not lift the cot by the backrest. Lift only by grasping the main frame.

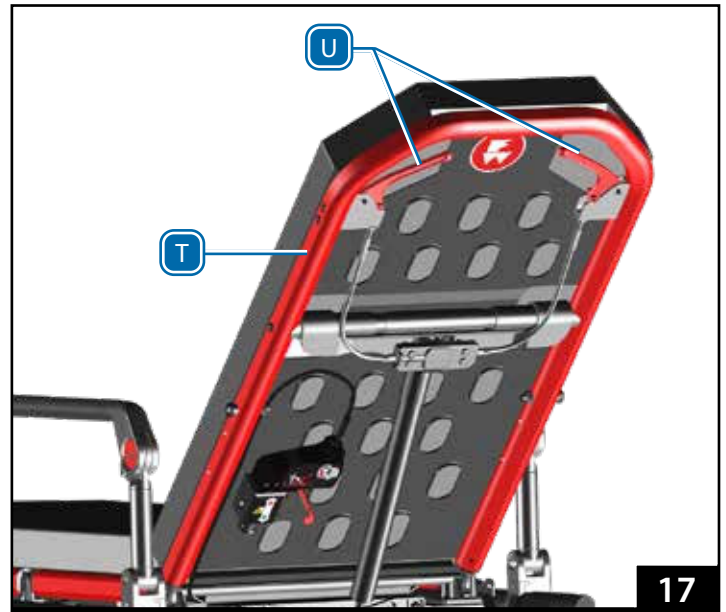

## 4.16 Safety-Bar Release Levers

Safety-bar release levers are located on the telescoping frame and loading-end legs (V, Figure 18). Use the levers to disengage each safety bar from the safety hook during the unloading process.

Turn the bottom of the lever away from the center of the cot to rotate the safety bar away from the safety hook.

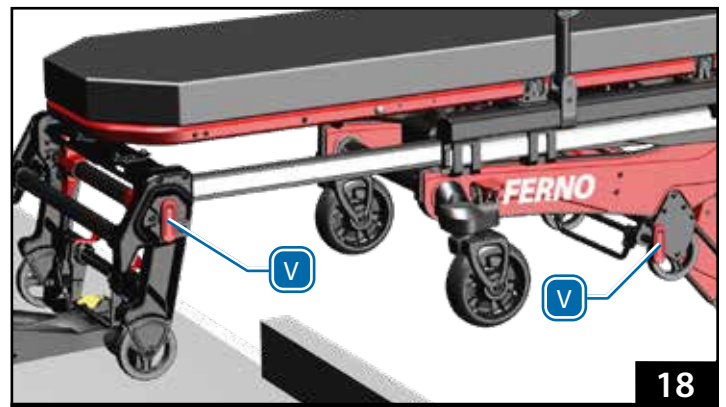

## 4.17 Wheel Locks

Wheel locks stop wheel rotation when engaged, and help keep the cot from rolling during patient transfer and certain medical procedures. Wheel locks are mounted to control-end transport wheels (Figure 19).

Press the red lever (W) down to engage the lock. Press the opposite end of the lever to unlock.

Wheel locks are not brakes. Do not use wheel locks to slow a cot while it is being rolled. Remain with the cot and keep control of it at all times. Do not leave the patient unattended.

### NOTICE

Wheel locks are not a substitute for operator control. The operators must remain with the cot and keep control of it at all times. Do not leave the patient unattended.

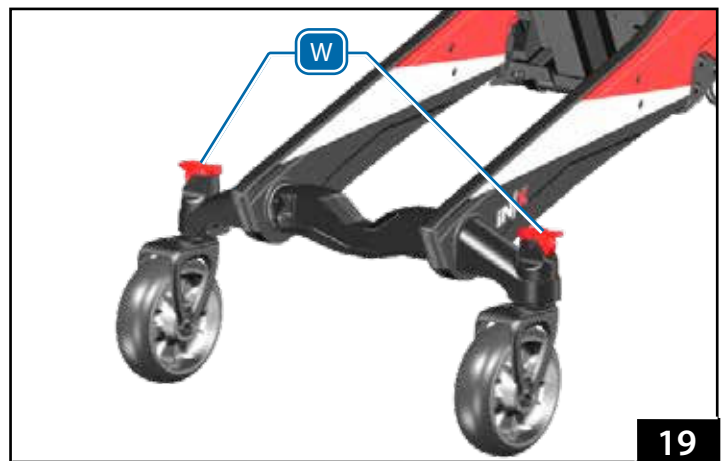

## 4.18 Telescoping Frame

The telescoping frame (X) shortens the cot to improve maneuverability in confined spaces. The frame locks at the extended and retracted positions. An additional, unlocked position shortens the cot further, when used with a raised backrest (Figure 20).

- Use only a locked position when lifting the cot.
- The frame must be locked in the extended position before loading the cot into an ambulance or unloading the cot from an ambulance.
- Do not fully lower the cot with the frame fully retracted.

To use the telescoping frame:

1. Loosen or unbuckle the restraints.
2. Raise the backrest.
3. Adjust and fasten the restraints.
4. Squeeze the telescoping frame release levers (Y, Figure 21) toward the lift bar and push or pull the frame. Release the levers and continue pushing or pulling the frame until it locks at the new position.

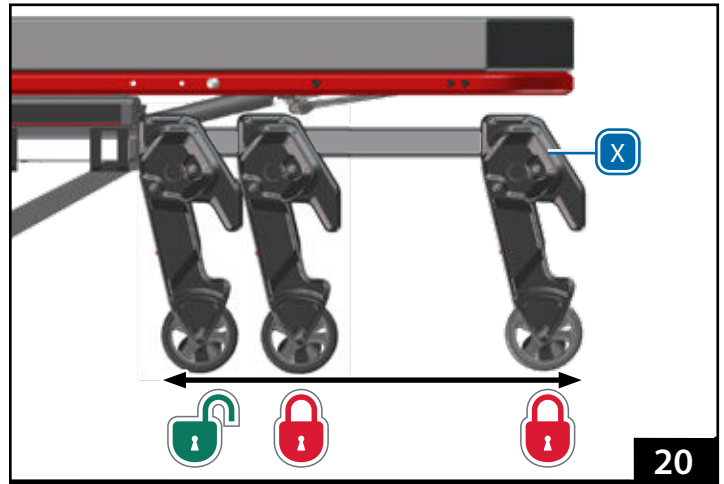

20

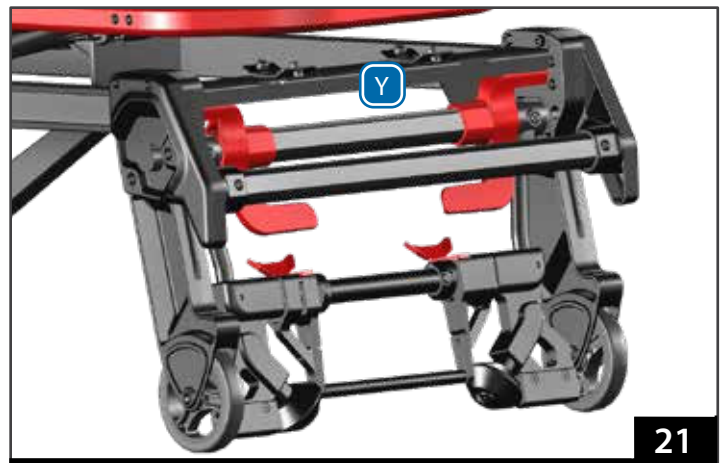

21

## 4.19 Mattress

The mattress is fitted with eight hooks (Z, Figure 22) to secure it on the patient surface. To attach the mattress:

1. Position the mattress with the hooks aligned over holes in the metal patient surface.
2. Raise the backrest and shock frame as needed.
3. Flex or press the mattress down as needed to guide each hook through the patient surface.
4. Confirm all eight hooks are engaged with the patient surface.

To remove the mattress, slide one hand between the patient surface and mattress, and guide the hooks through the patient surface.



22

## 4.20 Fold-Down Sidearm (Option)

Fold-down sidearms (AA, Figure 23) provide patient security and comfort. To lower a sidearm, press the release button and lower the sidearm. To raise a sidearm, lift the sidearm up until it locks into position.

### NOTICE

Do not use fold-down sidearms or the SX Surface Xtender to lift the cot. Grasp and lift only using the cot main frame.

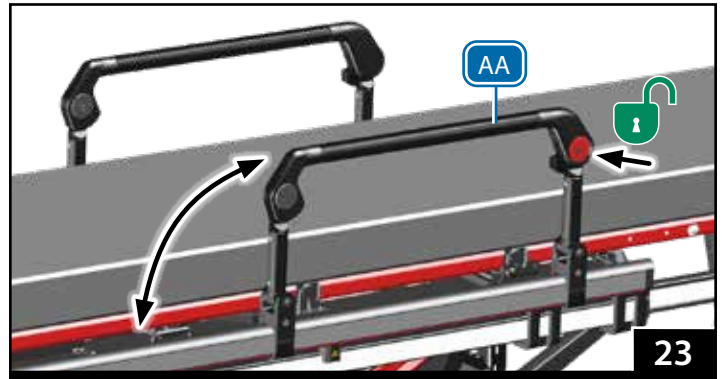

## 4.21 SX Surface Xtender (Option)

SX surface extenders (BB, Figure 24) provide patient security and comfort, and can widen the patient surface for large patients. SX also provides a location to place a patient's arm to start an IV. Each side locks individually. There are five locking positions and an unlocked, 'down' position (Figure 24).

A safety feature prevents the mechanism from operating when there is weight on the SX. To lower the SX, raise the SX slightly to take the weight off the lock mechanism, squeeze the red release lever, and lower the SX to the desired position.

To raise the SX, rotate the SX up to the desired position. There is no need to use the release lever.

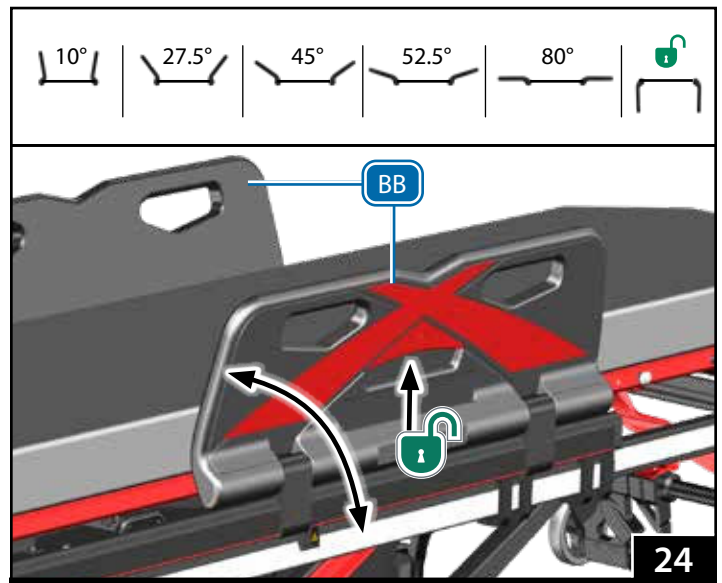

## 4.22 Non-Powered Operation (Manual Mode Handles)

Manual mode handles (CC, Figure 25 inset) allow non-powered operation in the event powered operation is unavailable. Each handle allows one set of legs to be raised or lowered without power. The handles are located under the shock frame (control-end legs) and below the backrest (loading-end legs).

To access the handle, pull the handle out of its storage mount. To re-secure, press the handle into the mount until it snaps into the locked position.

Refer to the non-powered operation sections of this manual to operate the cot manually.



### 4.23 Patient Restraint System

The patient-restraint system includes a combination pelvis strap/shoulder harness, chest strap, and two-piece leg restraint (DD, Figure 26). For placement and operation, refer to the restraint users' manual supplied.

### 4.24 Accessory Rail

The cot main frame (EE, Figure 26) acts as an attachment point to secure a variety of accessories. Accessories may be attached to either side of the cot, with a few limitations. For information on attaching, placing and using accessories, see page 46.

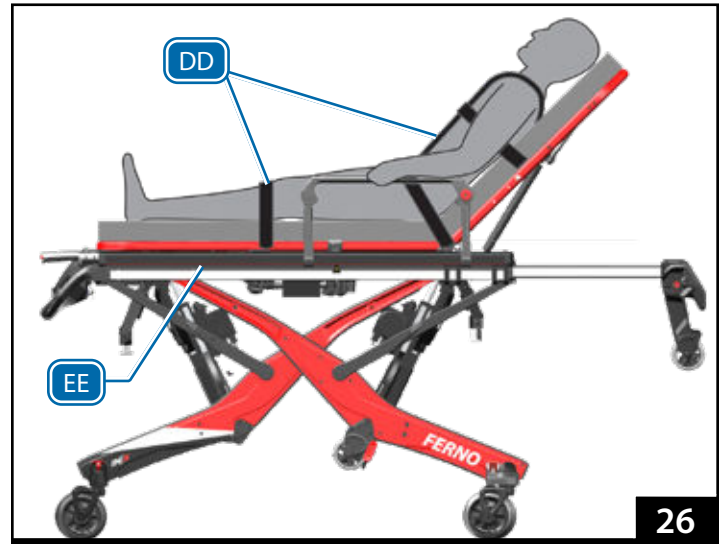

26

### 4.25 Oxygen Cylinder Holder

The oxygen-cylinder holder (FF, Figure 27) is mounted to the telescoping frame. It can carry a D or Jumbo D-sized portable oxygen cylinder, up to a maximum 5.3" by 18.75" (135 mm x 476 mm). Spiracle Technology's "DD-Lite" oxygen cylinder is also compatible.

To adjust the holder to fit a different cylinder, see "Adjusting the Oxygen Cylinder Holder" on page 42.

To secure a cylinder on the holder:

1. Center the cylinder on the holder. Wrap the fastening strap around the cylinder and thread the strap through both D-rings (GG, inset).
2. Thread the fastening strap back through one D-ring (HH, inset).
3. With one hand holding the oxygen bottle in place, pull the strap to cinch it tight.
4. Repeat to secure the second strap.

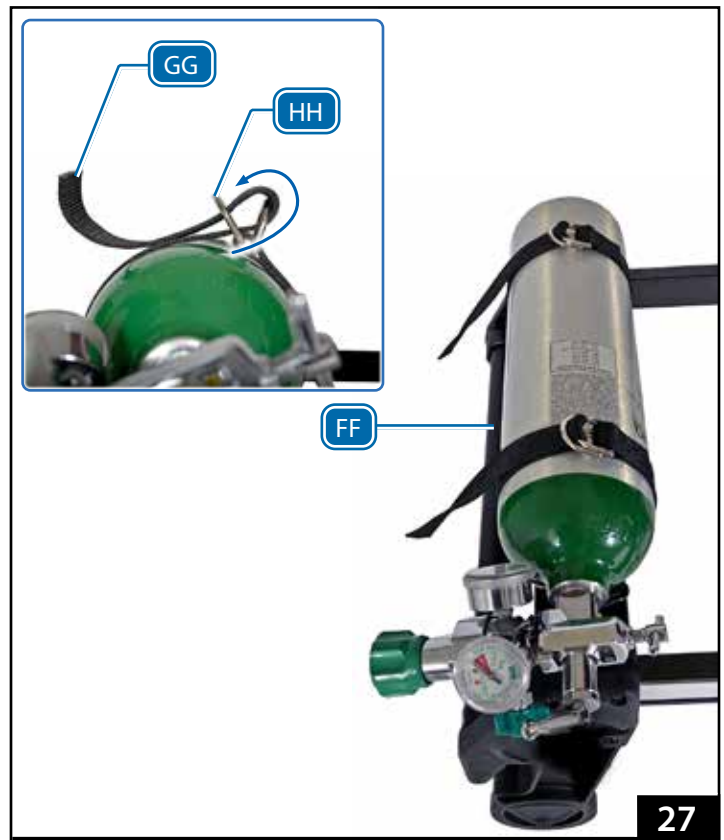

27





## 5 - USING THE COT

### 5.1 Before Placing the Cot in Service

- Before use, personnel who will work with the cot must read and understand this manual. Appropriate skills and training are also required. See page 8.
- Set up the cot. See page 44.
- Inspect and confirm the cot operates properly. See page 37.
- Set the loading height for the ambulance you will use with the cot (page 44).
- The vehicle must have a compatible Ferno or other certified fastening system installed.

### 5.2 General Guidelines for Use

Medical advice is beyond the parameters of this manual. It is the operators' responsibility to ensure safe practices for the patient and themselves. A minimum of two trained operators is required.

- Follow standard emergency patient-handling procedures when operating the cot.
- Communicate with one another and use coordinated movements to operate the cot.
- Talk to the patient. Communicate before making changes to the cot height, and during the loading and unloading procedures.
- Work together and maintain control of the cot at all times.
- Stay with the patient at all times. Do not leave a patient unattended.
- Select and use appropriate, compatible patient restraints to secure the patient on the cot. A list of Ferno patient restraint systems compatible with the cot is at right.
- Operators and helpers provide lift assistance only when the load exceeds the load capacity. Inspect the cot if the load capacity has been exceeded. See "Inspecting the iNfX" on page 37.
- Use additional help as needed (page 10).
- Read the fastening system users' manual for instructions on using the fastening system.
- To activate the cot after turning the power switch ON, or to wake the cot from Sleep Mode, press . Note: Only the  button will activate/wake up the cot.
- No-Lift Loading/Unloading: Do not lift the cot off the ground when using the cot powered mode.
- Auto-Equalize: When  or  is pressed, the cot extends or retracts one set of legs until both sets of legs are equally extended. Then, both sets of legs extend or retract simultaneously.
- Two systems alert the operators to important or unsafe conditions or faults. The display shows symbols/codes to indicate an error or condition. Also, the cot beeps when a status indicator is displayed. The severity of the status determines the number of beeps.

#### WARNING

**Improper operation can cause injury. Operate the cot only as described in this manual.**

**An unattended patient can be injured. Stay with the patient at all times.**

**An unrestrained patient can be injured. Use properly-installed patient restraints to secure the patient on the cot.**

**Rolling the cot above the factory-set maximum transport height can cause it to tip. Only roll the cot at or below the factory-set maximum transport height.**



#### LOAD CAPACITY

Inspect the cot if the load capacity has been exceeded (page 37).

#### Available Ferno Patient Restraint Systems

Ferno Product	Metric Patient Weight	Imperial Patient Weight
Kangoofix Neonate Transfer Aide	1.6-5 kg	3.5-11 lb
679 Neomate Infant Restraint System	2.3-6.4 kg	5-14 lb
678 PediMate®	4.5-18.1 kg	10-40 lb
PediMate+	4.5-45.4 kg	10-100 lb
417-3 Restraint system (supplied)	Up to Rated Load Capacity	

### 5.3 One Operator, Empty Cot

If local protocols permit, an empty cot (no patient) may be operated by one trained operator. Always use two operators when a patient is on the cot. Follow the instructions in this manual to raise, lower, load the cot into, or unload the cot from an ambulance.

Reminder: Do not lift the cot. Allow the powered system to do the work.

### 5.4 Powered Extending/Retracting

Extending or retracting the legs with a patient on the cot requires a minimum of two trained operators who are communicating, working together, and maintaining control of the cot at all times.

The color of the cot on the display assists in understanding the height condition of the cot. See "Display Zones" on page 15.

Be aware that the cot automatically stops at the minimum height, transport height, user-set loading height, and at the maximum height. To continue, press **+** or **-**.

1. Loading-end Operator: Extend the telescoping frame if needed before the position change.
2. Both Operators/Trained Helpers: Keep both hands on the cot main frame. Maintain control of the cot so it does not shift when extending or retracting the legs. During the position change, move with the cot and maintain your grasp on the main frame.
3. Control Operator: Press **-** to activate the cot after turning the power ON, or to awaken the cot from Sleep Mode.
4. Control Operator: Press **+** or **-** (O, Figure 28) until the cot reaches the desired height.

#### PROVIDING LIFT ASSISTANCE

The cot load capacity is 700 lbs/318 kg. Loads exceeding this limit may require lift-assistance from the operators/trained helpers. If the cot will not extend the legs, follow the procedure below. Always maintain control of the cot with both hands on the main frame.

Use additional help as needed (page 10).

1. Both Operators and Helpers: Operators stand at opposite ends of the cot and use an underhand grip (palms up) to grasp the main frame. Direct trained helpers where to stand and how to grasp the cot.
2. Control Operator: Communicate with the Loading-end Operator and trained helpers, then press **+**.
3. Both Operators and Helpers: Allow the cot to lift the load. Provide lift-assistance only for the portion of the load that exceeds the load capacity. Together, raise the cot to the desired height, then hold the cot at that position.
4. Both Operators and Helpers: Slowly lower your hands to test and verify that the cot has stabilized at the new position.

#### WARNING

**Uncontrolled movement can cause injury or damage. Support and control the cot at all times.**

#### NOTICE

Operators must maintain a firm grasp on the main frame and control the cot at all times. Be prepared to help raise or lower the cot.

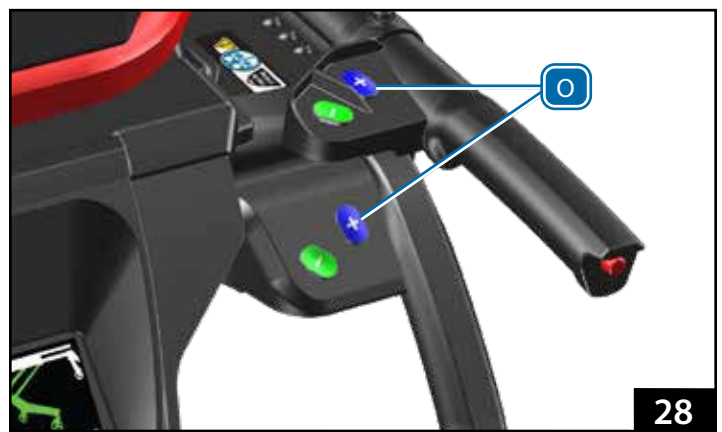

28

## 5.5 Transferring the Patient

If the load (patient plus equipment) exceeds the load capacity, the cot legs may not extend when a button is pressed, and/or one or both ends of the cot may settle downward several inches. See "Providing Lift Assistance" on page 25.

To transfer the patient onto the cot:

1. Place the cot beside the patient. Press **+** or **-** to adjust the cot to the patient's level.
2. Lock the wheel locks. If needed, lower the sidearms or SX Surface Xtenders.
3. Unfasten the patient restraints. Arrange the straps so they will not interfere with transferring the patient onto the cot.
4. Transfer the patient onto the cot using approved emergency-medical procedures and following local protocols.
5. Adjust the backrest, shock frame, and sidearms or SX as needed for patient comfort or medical care.
6. Fasten and adjust the patient restraints (Figure 29). Refer to the restraint users' manual for application of restraints.
7. Before moving the cot or changing its position, confirm sheets and other articles will not interfere with cot operation.
8. Unlock the wheel locks.
9. Press **+** or **-** until the cot reaches the desired height.

To transfer the patient off the cot:

1. Roll the cot near the destination surface. Press **+** or **-** to adjust the cot to, or slightly above, the destination surface.
2. Lock the wheel locks. If needed, lower the sidearms or SX.
3. Unfasten the patient restraints. Arrange the straps so they will not interfere with transferring the patient off the cot.
4. Transfer the patient onto the destination surface using approved emergency-medical procedures and following local protocols.
5. Fasten and arrange the patient restraints so they will not interfere with using the cot.
6. Before rolling the cot or changing its position, confirm sheets and other articles will not interfere with cot operation, unlock the wheel locks, and adjust the cot height as needed.

### **WARNING**

**Sheets or other objects can interfere with, or become entangled in, the actuator or legs, which can cause injury and/or malfunction, including unexpected retracting of the cot legs. Tuck sheets between the mattress and patient surface. Keep other articles above the mattress.**

### **NOTICE**

Sheets or other articles can become caught in the locking mechanism. Tuck sheets between the mattress and the patient surface. Keep other articles above the mattress.





30

## 5.6 Transferring the Patient: Chair Position

The chair position allows a patient to be transferred to a seated position onto the cot. Follow local protocols to determine the best situations to use chair position.

1. Roll the cot toward the control-end to position all four swivel wheels in the same orientation.
2. Raise the shock frame.
3. Press the chair-position button (E, Figure 30). When the button is pressed, a 15-second timer begins. To cancel, press the chair-position button again or allow the timer to expire.
4. Before the timer expires, press . Maintain control of the cot as the legs adjust to place the cot in the chair position (Figure 30).
5. Lock the wheel locks.
6. Unbuckle the restraints and lower the sidearms or SX.
7. Adjust the backrest to suit the patient.
8. If needed, have one operator or assistant steady the cot so it will not move as the patient is seated.
9. Assist the patient onto the cot following approved emergency-medical procedures and local protocols.
10. Fasten and adjust the patient restraints.
11. Before moving the cot or changing its position, confirm sheets and other articles will not interfere with cot operation.
12. Inform the patient before adjusting the cot height.
13. Verify the display is not showing the chair position screen: the regular operating screen should appear after the timer expires.
14. Press or until the cot reaches the desired height.
15. Adjust the backrest, shock frame, sidearms or SX as needed for patient comfort or medical care.
16. Unlock the wheel locks.

## 5.7 Rolling the Cot

Rolling the cot with a patient on it requires a minimum of two trained operators who are communicating, working together, and maintaining control of the cot at all times. Use additional help as needed (page 10).

Roll the cot on smooth, unobstructed surfaces whenever possible. Do not roll the cot sideways or push the cot using the backrest. Roll the cot only with both hands grasping the cot main frame.

Roll the cot only at or below the recommended transport height. Rolling above this height can increase the chance for the cot to tip. An audible alarm sounds when the cot is above the maximum transport height.

Note: The cot allows full 360° maneuverability at any height, even when fully folded.

1. Fasten and adjust the patient restraints.
2. Control-end Operator: Press **+** or **-** to adjust the cot height to, or below, the factory-set maximum transport height.
3. Both Operators/Trained Helpers: Operators position themselves at the ends of the cot, grasp the main frame with both hands and maintain control of the cot. Direct trained helpers where to stand and how to grasp the cot.

### CROSSING OBSTACLES

Use the cot auto-equalize feature to cross curbs, steps, porch decks, or similar high obstacles.

1. Both Operators: Roll the cot to the obstacle, with one set of transport wheels at the edge of the obstacle.
2. Operator Nearest the Obstacle: Position yourself on firm ground on the destination side of the obstacle. Support the load of your end of the cot (use additional help as needed). Do not lift.
3. Control Operator: Press **+** or **-** twice to adjust the legs to cross the obstacle. Stop when the transport wheels are at the appropriate height to cross or roll onto or over the obstacle.
4. Both Operators: Together, roll the cot partway onto the new surface (Figure 31). The operator nearest the obstacle can relax his/her grasp when the cot is fully supported on the new surface. Continue rolling the cot to position the second operator near the obstacle.
5. Both Operators: Repeat Steps 2-4 with the control-end operator supporting the load, adjusting the cot legs, and with both operators maneuvering the cot over the obstacle and/or onto the new surface.

### **WARNING**

**Rolling the cot above the factory-set maximum transport height can cause it to tip. Only roll the cot at or below the factory-set maximum transport height.**

**Rolling the cot sideways can cause it to tip and injure the patient and/or operators. Roll the cot only toward the control end or loading end.**

**Pushing the cot by the backrest can cause it to tip and injure the patient and/or operators. Roll the cot only by grasping the main frame.**

**Trained operators must consider the environment and terrain before rolling. Rolling the cot in a lowered position will minimize the potential of a cot tip.**



## 5.8 Loading the Cot

Loading the cot into an ambulance with a patient on it requires a minimum of two trained operators who are communicating, working together, and maintaining control of the cot at all times. Use additional help as needed (page 10).

To set the loading height, see page 44.

Do not lift the cot. Follow the instructions in this section.

1. Trained Operators:
  - o Raise the ambulance folding bumper, if present.
  - o Extend the telescoping frame.
  - o Roll the cot near the patient compartment door.
  - o Align cot parallel with the ambulance side walls during loading.
2. Control-End Operator: Press **+** to raise the cot to the user-set loading height. The loading wheels should be level with the ambulance floor. If needed, press **+** or **-** to adjust.
3. Both Operators/Trained Helpers: Align the cot with the fastening system, then roll the cot into the ambulance until the loading wheels and load-frame safety bar pass the safety hook.
4. Loading-End Operator: Confirm the safety bar has been captured by the safety hook (Figure 32).
5. Both Operators: Pull the cot against the safety hook to confirm it is secure. If not, adjust and retry (Figure 32).
6. Control-End Operator: Press **-** to begin retracting the loading-end legs. The legs will retract slightly, then stop when they are no longer supporting the weight of the cot. This is a safety check to verify that the load is being supported. Press **-** again to completely retract the loading-end legs. When the loading-end legs are fully retracted, the control-end legs “kick-up” to position the control end slightly above the level of the ambulance floor to promote smooth rolling.
7. Both Operators/Trained Helpers: Push the cot into the ambulance until the intermediate safety bar passes the safety hook. Use the red indicator line to help confirm the intermediate loading wheels are on the floor.
8. Control-End Operator: If needed, press **-** to lower the intermediate wheels to the floor.
9. Loading-end Operator: Confirm the safety bar has been captured by the hook (Figure 33).
10. Both Operators: Pull the cot against the safety hook to confirm it is secure. If not, adjust and retry (Figure 33).
11. Control-End Operator: Press **-** to begin retracting the control-end legs. The legs will retract slightly, then stop when they are no longer supporting the weight of the cot. This is a safety check to verify that the load is being supported. Press **-** again to completely retract the control-end legs.
12. Control-end Operator: If needed, extend the telescoping handles to help maneuver the cot into the fastening system. Retract the handles before closing the ambulance rear doors.
13. Both Operators: Push the cot completely into the fastening system and confirm it is locked into the fastening system. If the equipped with ICS, confirm the ICS has disabled cot power and begins charging the battery.
14. Do not press **+** or **-** buttons while the cot is inside the ambulance.

### ⚠ WARNING

Failure to engage the safety hook during loading or unloading can cause injury. Operators must visually ensure each safety bar engages the safety hook and the cot is secure inside the ambulance before extending or retracting the legs.

### NOTICE

If the ambulance is parked on an uneven surface, the operators (and any helpers) may need to extend the legs higher than the user-set loading height to allow the cot to roll into the ambulance.



## 5.9 Unloading the Cot

Unloading the cot from an ambulance with a patient on it requires a minimum of two trained operators who are communicating, working together, and maintaining control of the cot at all times. Use additional trained helpers as needed (page 10).

Do not lift the cot. Follow the instructions in this section.

1. Either Operator: Raise the ambulance folding bumper, if present.
2. Control-end Operator: Press the iN|LINE release button to unlock the cot, roll the cot a few inches toward the rear of the ambulance, and press **+** to activate the cot.
3. Both Operators/Trained Helpers: Grasp the cot with both hands and roll the cot out of the ambulance until the safety hook captures the center of the intermediate safety bar (Figure 34).
4. Loading-End Operator: Confirm the safety bar has been captured by the safety hook. Use the red indicator line to help confirm the intermediate loading wheels are on the floor.
5. Both Operators: Pull the cot against the safety hook to confirm it is secure. If not, adjust and retry.
6. Control-end Operator: Press **+** to extend the control-end legs.
7. Control-end Operator: Tell the Loading-end Operator to disengage the intermediate safety bar from the safety hook.
8. Both Operators/Trained Helpers: Roll the cot out of the ambulance until the safety hook captures the center of the loading-frame safety bar.
9. Loading-End Operator: Confirm the safety bar has been captured by the safety hook (Figure 35).
10. Both Operators: Pull the cot against the safety hook to confirm it is secure. If not, adjust and retry.
11. Control-end Operator: Press **+** to extend the loading-end legs.
12. Control-end Operator: Tell the Loading-end Operator to disengage the load-end safety bar from the hook.
13. Both Operators: Roll the cot completely out of the ambulance. As the cot is rolled away from the safety hook, the Loading-end Operator may let go of the safety-bar release lever.
14. Control-end Operator: Press **-** to lower the cot to the factory-set transport height before rolling the cot.

### ⚠ WARNING

Failure to engage the safety hook during loading or unloading can cause injury. Operators must visually ensure each safety bar engages the safety hook and the cot is secure inside the ambulance before extending or retracting the legs.

### NOTICE

If the ambulance is parked on an uneven surface, the operators (and any helpers) may need to extend the legs higher than the user-set loading height to allow the cot to roll into the ambulance.

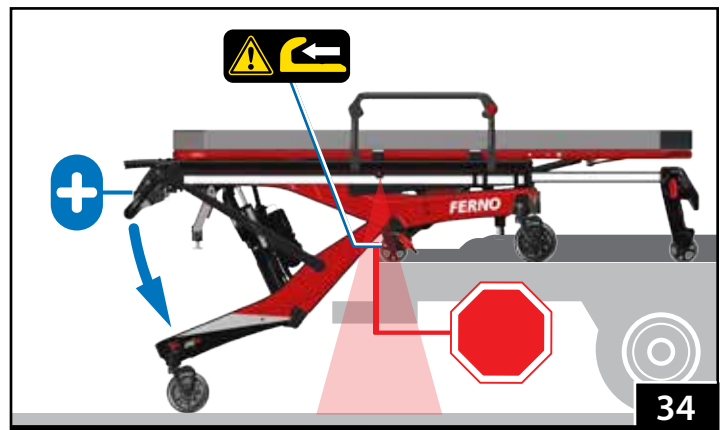

## 5.10 Direct Power Modes

Direct Power is a secondary method of operating the cot and is not part of normal operation. It is identified by the white background and blue cot legs on the display. Red wheels indicate the cot must not be rolled. During normal operation, the display background is black.

Direct Power allows independent control of one or both sets of legs. Select from three options using the mode button on the left side of the display (B, Figure 36). Use additional help if needed (page 10).

### ABOUT DIRECT POWER

- Use caution when using Direct Power with a patient on the cot.
- Auto-equalize is off. The cot will not automatically maintain an even extension between the loading-end and control-end legs. Operators must maintain control of the cot. Do not put the patient at a severe angle as patient and/or operator injury can occur if the load shifts.
- When using Direct Power, the cot extends and retracts the legs at a slower speed than when using the normal powered mode.
- In each direct power mode, a countdown timer counts down from 15 seconds. If no further action is taken, the cot reverts to its standard operating mode.

### SELECTING DIRECT POWER

Press button (B) to select Direct Power. Each button press cycles to the next mode (Figure 37). The button-press sequence is:

1. Direct Power Both Legs (II). Both sets of legs move when **+** or **-** is pressed. Depending on the weight on the cot, one set of legs may extend or retract more quickly than the other.
2. Direct Power Loading-end Legs Only (JJ). Only the loading-end legs move when **+** or **-** is pressed.
3. Direct Power Control-end Legs Only (KK). Only the control-end legs move when **+** or **-** is pressed.
4. Set Load Height. See page 44.
5. The fifth button-press returns the cot to its standard operating mode.

### WARNING

**A severe angle can injure the patient and/or operators. Control the cot when using a direct power mode.**

### NOTICE

If an obstruction prevents the cot from moving, stop pressing **+** or **-** and carefully remove the obstruction before continuing. Direct power is not needed.

When using direct power, the auto-equalize feature is disabled. Do not place the cot at a severe angle where the patient or equipment could shift and become unbalanced.

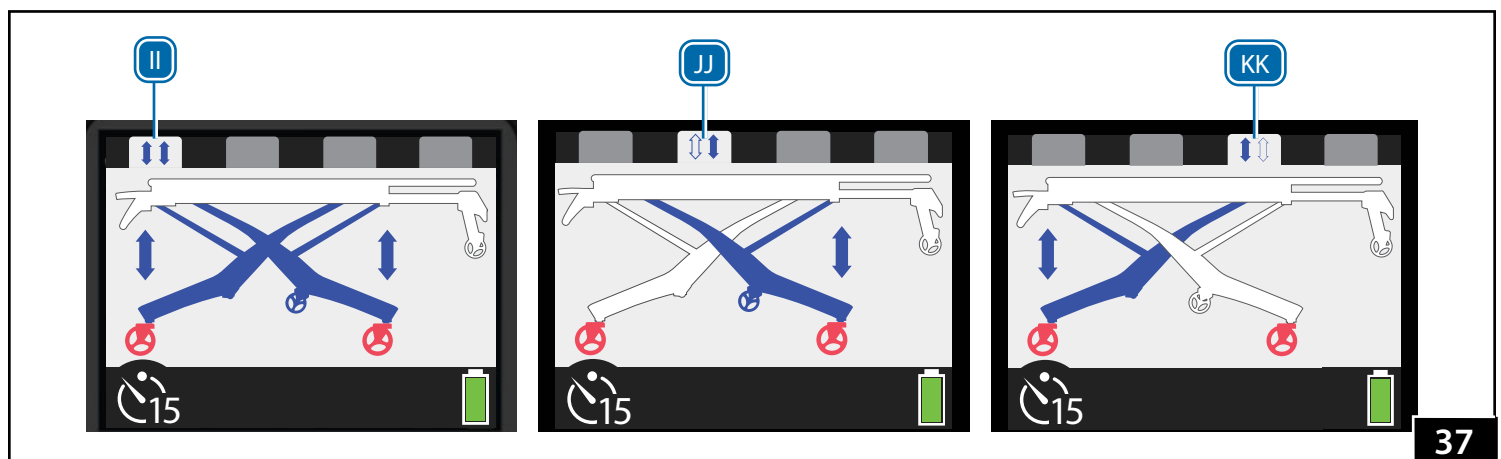

## 5.11 Non-Powered Operation: Extending and Retracting

To extend or retract the legs without power, use the manual mode handles. Refer to the placement of operators in the table below.

- Extend the telescoping frame before raising or lowering the cot.
- Lift the cot slightly before squeezing an manual mode handle. This ensures that you are holding the load.
- Adjust each leg individually by a small amount. Repeat until the cot is at the desired height. Use additional help if needed (page 10).
- Both Operators communicate and work together while extending or retracting the legs. Do not place the patient at a severe angle.
- Raise the backrest and/or shock frame as needed. Release the manual mode handles from their mounts (Figure 38).

### EXTENDING

When extending the cot without power, begin at the loading end. Raise the loading-end legs first, then the control-end legs.

1. Lead Operator/Trained Helpers: Lift and hold the loading end of the cot several inches off the ground. Tell the handle operator you are ready for the position change.
2. Handle Operator: Squeeze the manual mode handle and push the legs down until the transport wheels are on the ground. Release the handle to lock the legs.
3. Lead Operator/Trained Helpers: Maintain your grasp on the cot. Verify it is stable at the new position.
4. All: Move to the control end of the cot and repeat Steps 1-3 until the cot is level, or raise the control end above the loading end.
5. All: Repeat Steps 1-4 until the cot is level at the desired height.

### RETRACTING

When retracting the cot without power, begin at the control end. Lower the control-end legs first, then the loading-end legs.

1. Lead Operator/Trained Helpers: Lift and hold the control end of the cot several inches off the ground. Tell the handle operator you are ready for the position change.
2. Handle Operator: Grasp the main frame and handle.
3. All: As the handle operator squeezes the handle, assist the retracting process. Release the handle to lock the legs.
4. Lead Operator/Trained Helpers: Maintain your grasp on the cot. Verify it is stable at the new position.
5. All: Move to the loading end of the cot and repeat Steps 1-4 until the cot is level, or raise the loading end above the control end.
6. All: Repeat Steps 1-5 until the cot is level at the desired height.

### FOLDING WITHOUT A PATIENT

To fold the cot with no patient, the operators stand at opposite ends of the cot and squeeze the handles at the same time. Control the descent of the cot and keep it level as you fold it.

### ⚠ WARNING

Uncontrolled movement can cause injury or damage.  
Support the load before using a manual mode handle.

A severe angle can injure the patient and/or operators.  
Control the cot when operating without power.

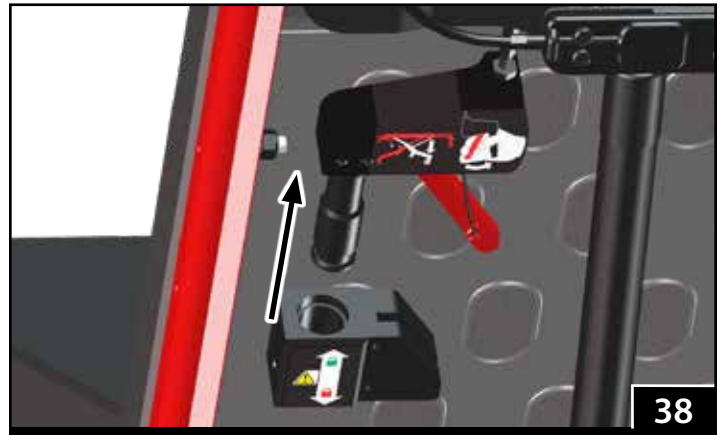

38



39

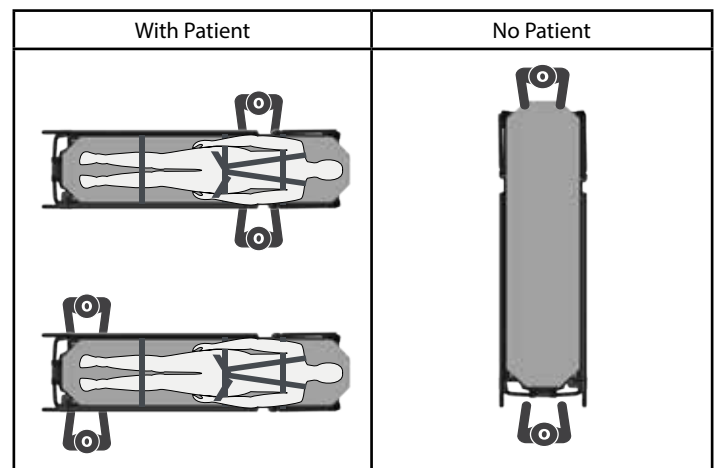

## 5.12 Non-Powered Operation: Loading

The cot's independent-leg design allows operators to reduce the amount of lifting required even when loading the cot into an ambulance without power. Use additional help as needed (page 10).

If medically appropriate, lower the backrest to lay the patient flat after retrieving the loading-end manual mode handle. This puts more of the load inside the ambulance and reduces the amount the operators must support during loading.

**Locking Clip:** As needed, use the locking clip (KK, Figure 40) to hold the handle in the compressed state. This allows the handle operator to use both hands to maintain control of the cot during non-powered loading and unloading.

1. Trained Operators:
  - Raise the ambulance folding bumper, if present.
  - Extend the telescoping frame.
  - Roll the cot near the patient compartment door.
  - Align the cot with, and keep it parallel to, the ambulance side walls during loading.
2. Both Operators: Raise the cot in stages to the ambulance loading height. Do not put the patient at an extreme angle. See "Non-Powered Operation: Extending and Retracting" on page 32.
3. Both Operators: Roll the cot into the ambulance and secure the loading-end safety bar on the safety hook. Confirm the cot is engaged with the hook before proceeding.
4. Handle Operator: Remove the loading-end manual mode handle from its mount under the backrest.
5. Both Operators: Stand together at the loading end of the cot. Grasp the main frame with one hand and the loading-end legs with the other hand.
6. Both Operators: Communicate and work together. As the handle operator squeezes the manual mode handle, both operators retract the loading-end legs. Release the handle to lock the legs.
7. Both Operators: Roll the cot into the ambulance until the intermediate safety bar passes the safety hook. Confirm the cot is engaged with the hook before proceeding.
8. Handle Operator: Squeeze the loading-end manual mode handle one more time to verify the loading-end legs have completely retracted. Position the handle out of the way so it will not interfere with the cot or fastening system.
9. Handle Operator: Remove the control-end manual mode handle from its mount under the shock frame.
10. Both Operators: Stand together at the control end of the cot. Grasp the main frame with one hand and the control-end legs with the other hand.
11. Both Operators: Communicate and work together. As the handle operator squeezes the manual mode handle, both operators retract the control-end legs. Release the handle to lock the legs.
12. Both Operators: Resume your grasp on the main frame and push the cot into the ambulance. Secure it in the fastening system.

### NOTICE

As you load the cot into the ambulance, arrange the manual mode handles and cables so they will not interfere with cot or fastening system operation.

### Urgent Non-Powered Loading

Optional: If enough operators and helpers are available, roll the cot to the ambulance and fully retract both sets of legs. Working together, the operators and helpers lift and set the cot inside the ambulance.

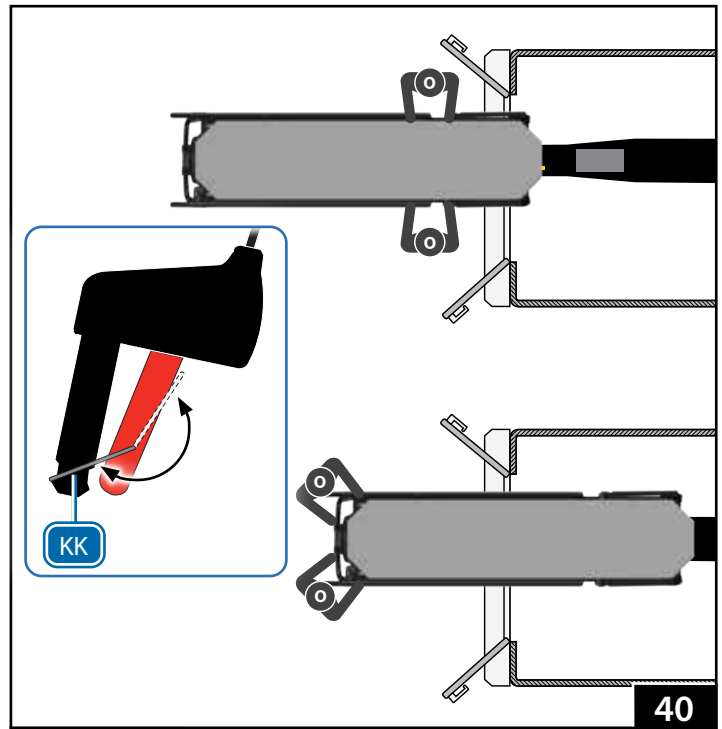

40

## 5.13 Non-Powered Operation: Unloading

The cot's independent-leg design allows operators to reduce the amount of lifting required even when loading the cot into an ambulance without power. Use additional help as needed (page 10).

If medically appropriate, lower the backrest and lay the patient flat after retrieving the loading-end manual mode handle. This puts more of the load inside the ambulance and reduces the amount the operators must support during loading.

**Locking Clip:** As needed, use the locking clip (KK, Figure 41) to hold the handle in the compressed state. This allows the handle operator to use both hands to maintain control of the cot during non-powered loading and unloading.

1. Either Operator: Raise the ambulance folding bumper, if present.
2. Either Operator: Remove the control-end manual mode handle from its mount under the shock frame.
3. Both Operators: Support and balance the load as the cot is rolled out of the ambulance in Step 3.
4. Both Operators: Disengage the cot from the fastening system. Roll it out of the ambulance until the intermediate safety bar engages the safety hook. Confirm the safety bar is engaged with the hook before proceeding.
5. Both Operators: Use additional help as needed to support the load.
6. Handle Operator: Squeeze the manual mode handle and extend the control-end legs to the ground. Release the handle to lock the legs in the extended position.
7. Both Operators: As one operator disengages the intermediate safety bar from the safety hook, roll the cot out of the ambulance until the loading-end safety bar engages the safety hook. Confirm the cot is engaged with the safety hook before proceeding.
8. Handle Operator: Remove the loading-end manual mode handle from its mount under the backrest.
9. Both Operators: Support and balance the load throughout the process.
10. Handle Operator: Squeeze the manual mode handle and extend the loading-end legs to the ground. Release the handle to lock the legs in the extended position.
11. Either Operator: Disengage the cot from the safety hook. Together, roll the cot out of the ambulance.
12. Both Operators: Lower the cot to a transport height, or fold it. See "Non-Powered Operation: Extending and Retracting" on page 32 to lower each end of the cot in stages until the cot is the desired height. Do not put the patient at an extreme angle.

### NOTICE

As you unload the cot from the ambulance, arrange the manual mode handles and cables so they will not interfere with cot or fastening system operation.

### Urgent Non-Powered Loading

Optional: If enough operators and helpers are available, roll the cot to the ambulance and fully retract both sets of legs. Working together, the operators and helpers lift and set the cot inside the ambulance.

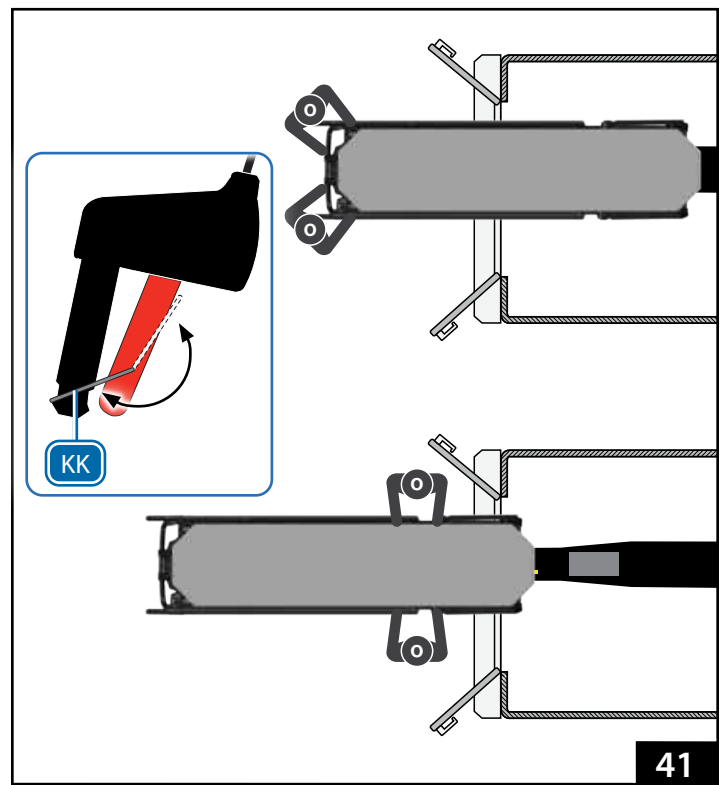

## 6 - MAINTENANCE

### 6.1 Maintenance Schedule

The cot requires regular maintenance. Set up and follow a maintenance schedule. The table at right represents minimum intervals for maintenance. Keep maintenance records. For a sample record sheet, see "Maintenance Record" on page 47.

When using maintenance products, follow the manufacturers' directions and read the manufacturers' material safety data sheets.

### 6.2 Service Life

Many factors affect a product's service life, including frequency of use (high-volume versus low-volume ambulance service); local environment (extreme temperature, high humidity, etc.); maintenance (adherence to the inspection and maintenance schedule); and other factors.

Follow the disinfecting, cleaning, and inspection procedures in this manual to ensure long life for the cot.

### 6.3 Disinfecting /Cleaning Restraints

Remove the restraints from the cot before cleaning/disinfecting them.

To disinfect: Apply disinfectant to all restraint surfaces, following the disinfectant manufacturer's instructions for application method and contact time. Wipe with a clean cloth. Do not immerse metal buckles or slide bars in liquid.

To clean metal buckles: Apply a disinfectant cleaner to the metal buckle, following the disinfectant manufacturer's instructions for application method and contact time. Wipe with a clean cloth. Do not immerse the metal buckles in liquid.

To clean the webbing:

1. Add a disinfectant cleaner to warm water, following the disinfectant manufacturer's instructions.
2. Immerse webbing in the solution for the time directed by the disinfectant manufacturer. Do not immerse the metal buckles or slide bars in the solution.
3. Repeatedly dip the webbing in clear water to rinse. Do not immerse the metal buckles or slide bars in liquid.
4. Hang the restraint to air-dry.
5. Attach only dry restraints to the equipment.

### 6.4 Disinfecting/Cleaning Mattress

Remove the mattress from the cot and inspect it. Replace the mattress if it is ripped, punctured or damaged.

To disinfect: Apply disinfectant to the mattress, following the disinfectant manufacturer's instructions for application method and contact time.

To clean: Wash the mattress with warm, soapy water and a soft cloth. Rinse the mattress with clear water. Hang the mattress to dry, or dry it with a towel. To attach the mattress to the cot, see page 21.

#### WARNING

**Improper maintenance can cause injury and damage. Maintain the cot and battery only as described in this manual.**

Minimum Maintenance	Each Use or Daily	As Needed	Monthly
Daily Operator Duties (page 8)	•		
Disinfecting (pages 35-36)	•		
Cleaning (pages 35-36)		•	
Pressure-Washing (page 36)		•	
Inspecting (page 37)	•	•	•
Manual Back-up Cable (page 33)	•	•	
Backrest Cable (page 34)		•	•

#### NOTICE

Disinfectants and cleaners containing phenolics or iodines can cause damage. Do not use products containing these chemicals. If bleach is used, rinse with plenty of clear water to remove bleach residue.

Using abrasive cleaning compounds or applicators on the cot can cause damage. Do not use abrasive materials to clean the cot.

Metal buckles and slide bars can be damaged by immersion in liquids or by washing-machine action. Disinfect and clean only as described in this manual.

Water under high pressure, or steam, can penetrate joints, flush away lubricant, and cause corrosion. Use caution when cleaning moving parts such as joints and hinges.

## 6.5 Disinfecting the Cot

Wipe all surfaces with disinfectant. Follow the disinfectant manufacturer's instructions for application method and contact time. Inspect the cot for damage as you disinfect it.

## 6.6 Cleaning the Cot

1. Remove the patient restraints, mattress, and accessories. Verify that all cords, cables, connectors, etc. are connected.
2. Remove the battery. Cover the battery cable plug with a bag. Tie the bag closed or use a rubber band to make a watertight seal around the plug. For battery care, see page 16 and Battery Care at right.
3. Hand clean all surfaces with warm water and a mild detergent, or pressure-wash the cot as described below. Do not spray water directly into ports, wire harnesses, cable connections, etc.
4. Rinse with warm, clear water. Dry with a towel or allow it to air-dry.

## 6.7 Pressure-Washing

IP 56: The cot has been tested in compliance with dust and water infiltration standards and has earned a Solid Particle Protection Rating of 5 (dust-protected), and Liquid Ingress Protection Rating of 6 (protected against water infiltration).

Use caution when using pressurized water, spray-wands and equipment. Wear all safety equipment recommended by the pressure-sprayer manufacturer. Do not pressure wash the battery.



Do Not Pressure Wash the Battery

1. Adjust the cot to the recommended transport height.
2. Use Direct Power (page 31) to fold the loading-end legs until the loading wheels are on the ground (Figure 42).
3. Turn the power switch OFF, engage the wheel locks, and remove the battery.
4. Cover the battery cable end with a plastic bag. Make the bag water-tight using a tie wrap or rubber band. Then, attach the battery cover (Figure 42 inset, LL, MM).
5. Set the nozzle pressure at or below 3000 psi (20,684 kPa). Use a nozzle with a wide angle of spray (25° or 40°). Keep the nozzle at least 18" (457 mm) away from the cot at all times (Figure 42). Do not spray directly into the control panel or wiring.
6. Spray the patient surface, legs, and wheels of the cot.
7. Allow the cot to sit idle for 10 minutes to dry.
8. Remove the battery cover, tie wrap or rubber band and bag from the battery cable. Attach the battery and put the cover in place.
9. Turn the power ON. Raise the cot to the desired height.
10. When fully dry, reattach the mattress, restraints, and accessories.

The IP Rating system was developed by the European Committee for Electrotechnical Standardization (CENELEC) to show compliance of ANSI/IEC 60529, Degrees of Protection Provided by Enclosures (IP Code).

## Battery Care

- The battery is water-resistant and is suitable for outdoor use. Do not submerge the battery in water. Do not dismantle, open or shred the battery.
- Remove the battery from the cot before pressure-washing the cot.
- Wipe battery terminals with a clean dry cloth if they become dirty or wet. Refer to the battery users' manual for disinfecting and cleaning instructions.
- Before washing or pressure-washing the cot, remove the battery and cover the battery cable plug with a bag.
- Recycle the battery when it can no longer maintain a charge. Do not dispose of batteries with municipal waste. See page 39.
- Replace a damaged or cracked battery.

## NOTICE

The cot is water-resistant. When pressure-washing:

- Remove the battery and cover the cable end with a plastic bag. Close the bag with a wire tie or rubber band.
- Keep nozzle pressure at 3000 psi/20,684 kPa or less, or 4 gallons per minute/15 liters per minute or less.
- Keep the nozzle at least 18"/457 mm from the cot at all times during cleaning.
- To clean the display, reduce water pressure and/or increase the distance (greater than 18"/457 mm).
- Do not spray water upward into the cables or forcibly at or around the display.



42

## 6.8 Inspecting the Cot

A basic inspection is recommended at the beginning of each operator shift. See "Daily Operator Duties" on page 8.

Have your service's equipment maintenance personnel inspect the cot regularly. Follow the checklist at right and operate the cot through all its functions as described in this manual.

If inspection shows damage or excessive wear, remove the cot from service until repair is made. See "Parts and Service" on page 46.

### Electrical Inspection

- Does the power switch function properly?
- Do the Extend and Retract buttons function properly?
- Does the powered system operate properly through the full range of motion?
- Does the powered system operate smoothly, without binding or excessive noise?
- Does the controller stop the cot at the transport height, user-set loading height, and at the fully-extended and lowered positions?
- Do the lights and position indicator lights operate as expected?
- Is there visible sign of damage to the controller case, display, battery, or battery charger?
- Does the battery attach properly to the cot?
- Does the display function properly?
- Are all cords and cables free of excessive wear, cuts, and fraying?

### Mechanical Inspection

- Are all components present?
- Is the cot free of excessive wear?
- Inspect for metal fatigue, cracks, or damage throughout the cot. Also remove the battery cover and battery, and inspect the frame areas covered by the battery.
- Is all hardware securely in place?
- Do all moving parts operate smoothly and properly?
- Does the cot load and unload properly?
- Does the safety hook engage each safety bar?
- Do the legs show signs of wear or damage?
- Does the cot roll smoothly?
- Do the wheels show excessive wear or damage?
- Do the wheel locks engage properly and stop wheel rotation?
- Do the wheel casters remain level and perpendicular to the ground through 360° rotation and through the full range of leg motion?
- Are the patient restraints properly installed?
- Is restraint webbing in good condition with no cuts or frayed edges?
- Are restraint buckles free of visible damage and do they operate properly?
- Is the ambulance properly prepared for the cot with an iNfLINE fastening system installed?
- Do installed accessories operate properly without interfering with cot operation?

## 6.9 Lubricating the Cot

Disinfect and clean the cot before applying lubricant. Use the lubricants designated below to lubricate the cot. Do not lubricate points marked with the “do not lubricate” symbol.

Use a small amount of lubricant (one or two drops). Lubricate identical points on each side of the cot (Figure 43). After applying lubricant, wipe off excess.

### LUBRICATION-FREE ITEMS

⊗	Wheels (sealed bearings)	Do not lubricate
⊗	Legs	Do not lubricate
⊗	Patient Surface	Do not lubricate

### LUBRICATION POINTS

1.	Safety Bar Pivot (slot, both sides)	WRL-191S, E-Z-1 light oil
2.	Slider Rail (both sides, both ends)	PTFE dry-film spray lubricant

**Safety Bar Pivot:** Apply lubricant as needed to the slot on both sides of the red handle. Wipe off excess.

**Slider Rails:** If the sliding rails squeak during use, clean the rails. If this does not solve the problem, clean and then apply a light coating of PTFE dry-film spray lubricant to the rails. PTFE is the generic name of products similar to Teflon® (a registered trademark of the DuPont Company, E. I. du Pont de Nemours and Company or its affiliates.)

### NOTICE

Lubricating parts that should not be lubricated allows dirt and foreign particles to collect on those parts, resulting in damage. Lubricate only the numbered reference points shown.

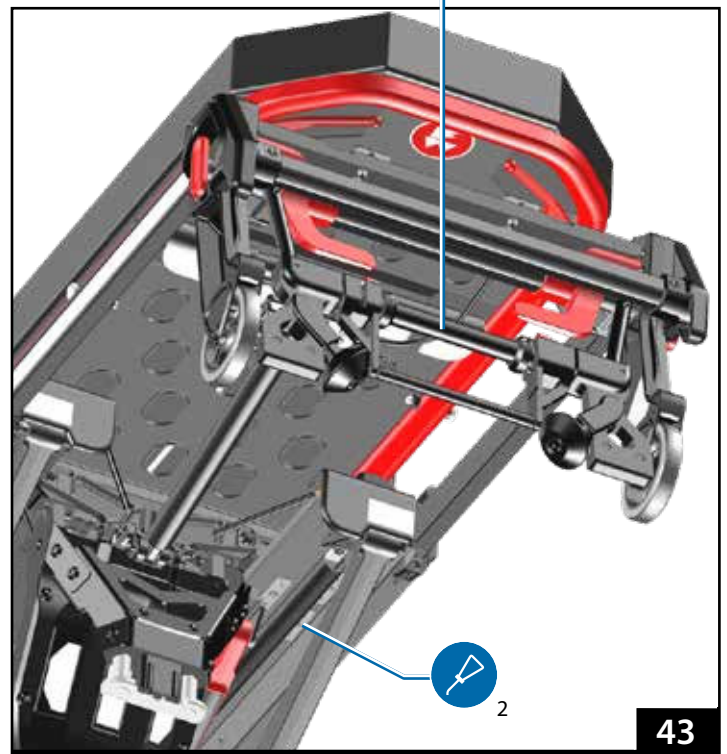
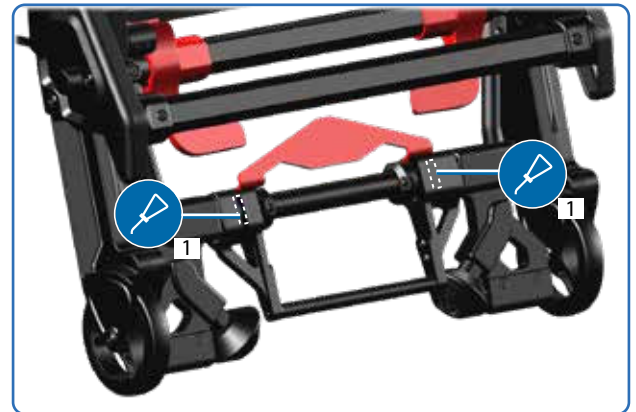

## 6.10 Storing the Cot

1. Lower the cot to the fully-retracted position (Figure 44). Turn the power switch OFF.
2. Remove and charge the battery. See "Battery" on page 16 and "Storing the Battery" below.
3. Cover the battery cable connector on the cot with a bag. Seal the bag (for example, with a rubber band) to prevent moisture from entering the connector.

Before returning the cot to service:

1. Fully charge the battery. Attach only a fully-charged battery.
2. Turn the power switch ON.
3. Have your service's equipment maintenance personnel inspect the cot. See "Inspecting the Cot" on page 37.



44

## 6.11 Storing the Battery

- Fully charge the battery before storing it. Do not store the battery with less than a full charge.
- Store the battery only in a cool, dry place. Battery capacity can be affected if the battery is stored for long periods outside of the recommended temperature range.
- After a period of storage, charge the battery fully before use.

### NOTICE

Before placing the battery in storage, charge the battery. Store only a fully-charged battery.

A battery with a very low charge may not be able to be charged by the ICS. Connect the battery directly to the charger separate from the ambulance and ICS.

## 6.12 Recycling Notice

The cot uses a rechargeable, 36 Volt DC lithium-iron battery (specifically "LiFePO4" as noted on the battery label, Figure 45).

Contact the government in your state, territory or country for proper recycling of the battery and charger. Do not dispose of the battery or charger with municipal waste.

**Battery:** Recycle the main battery when it can no longer hold a charge..

**Charger:** Recycle the charger if it becomes damaged or fails to properly charge the battery.

### WEEE DIRECTIVE (EUROPEAN UNION)

European Union directive 2002/96/EC Waste Electrical and Electronic Equipment (WEEE) limits the disposal of electrical and electronic equipment in landfills. Contact the government in the country in which you reside for recycling information.

### U.S.A.

In the U.S.A., contact TerraCycle Regulated Waste to responsibly recycle and dispose of the Ferno 36VDC Lithium-iron phosphate battery. Visit <https://tcrwusa.com/>.

Contact the Environmental Protection Agency in your state to dispose of a damaged or nonfunctional charger.



45

### NOTICE

If the battery sustains noticeable or suspected damage or is hot to the touch, immediately remove it from service and store outside of a building.

## 6.13 Adjusting Backrest Control Handles

The cable attached to the backrest control handle (Figure 46) may require occasional adjustment to retain proper function.

If the backrest lowers without operating the control handle, the cable is too tight. Decrease cable tension.

If the backrest does not lower when the control handle is used, or lowers too slowly, the cable is too loose. Increase cable tension.

Follow the same procedure for each control handle.

1. Loosen the jam nut (NN) with an 11 mm wrench.
2. Use the 11 mm wrench to hold the jam nut in place (to prevent it from rotating) , use an 8 mm wrench to adjust the cable nut (OO) until the control handle functions properly. Viewed from the top of the backrest, rotate the cable nut counterclockwise (anticlockwise) to decrease cable tension or clockwise to increase cable tension.
3. Confirm that each backrest handle functions properly. Adjust the tension of each cable until proper handle function is achieved.
4. Tighten the jam nut.

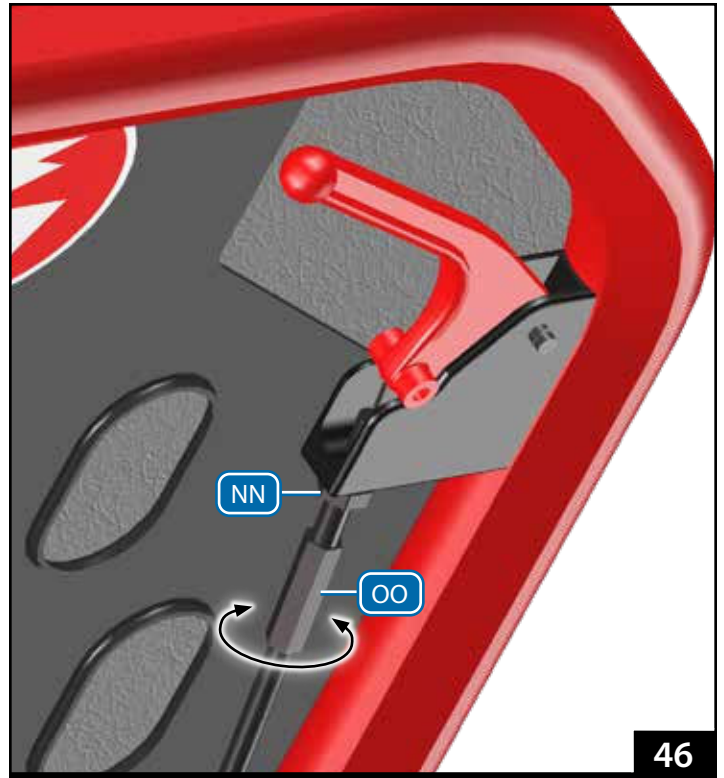

46

## 6.14 Adjusting Position Indicator Lights

To adjust the indicator lights:

1. Partially-load the cot into the ambulance until the loading-end safety bar is secure on the safety hook. See "Loading the Cot" on page 29 and (Figure 47).
2. Use a 2 mm hex wrench to loosen the set screw (PP) at the side of the position indicator light (Figure 47 inset).
3. Use a slotted screwdriver to slightly rotate the light unit inside the housing. Align both indicator lights to form a straight line on the ground.
4. Tighten the set screw.

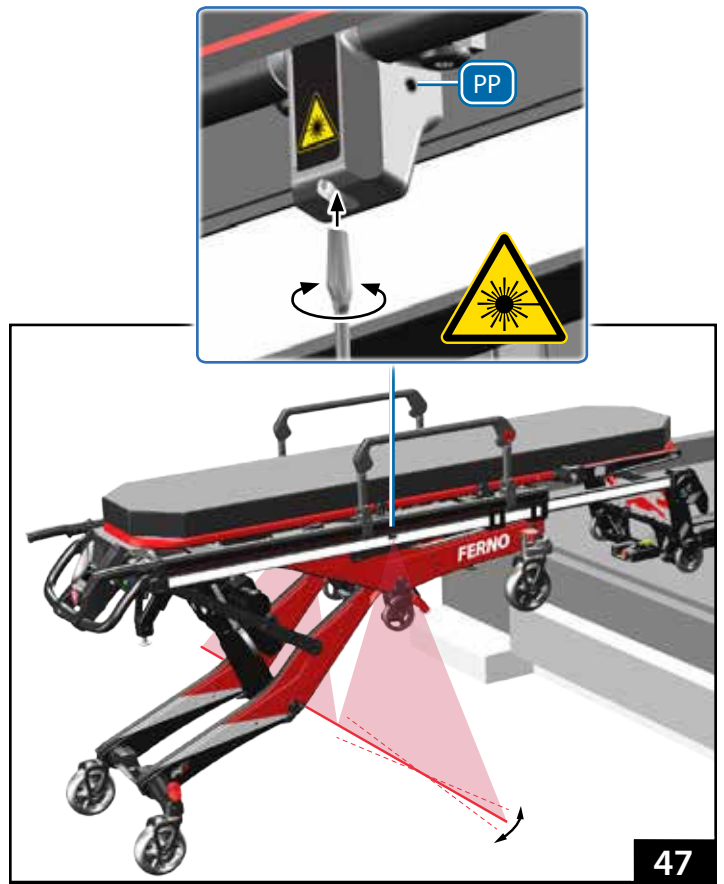

47

## 6.15 Adjusting Manual Mode Handles

The manual mode handle cables may require occasional adjustment to retain proper function.

If the cot lowers without operating the handle, the cable is too tight. Decrease cable tension.

If the cot does not lower when the handle is used, or lowers too slowly, the cable is too loose. Increase cable tension.

Use caution when adjusting the cable tension. Use a second person (minimum) for assistance.

1. Use a 9/16" (14 mm) open-end wrench to loosen the jam nut (QQ, Figure 48).
2. Use the wrench to hold the cable nut (RR) to prevent it and the cable from rotating.
3. Rotate the handle assembly. As you look at the top of the handle assembly, rotate the handle assembly clockwise to decrease cable tension or counterclockwise (anticlockwise) to increase cable tension.
4. When the adjustment is correct, tighten the jam nut snug-tight. Do not overtighten.
5. Place approximately 150 pounds (68 kg) of weight on the cot. (For example, use bags of sand.) Confirm that each manual mode handle functions properly. Adjust the tension of each cable until proper handle function is achieved. If the cable cannot be adjusted satisfactorily, contact Ferno for repair. See "Parts and Service" on page 46.
6. Tighten the jam nut (QQ).

### WARNING

**Improper adjustment of the manual mode handle cables can lead to injury. Adjust cable tension when needed.**

**The cot can rapidly descend and cause injury if the manual mode handles are activated while you are adjusting the cable tension. Use caution when adjusting cable tension.**

### NOTICE

Improper cable tension can damage the cot. Adjust the cable for proper function as needed.

Use caution when adjusting the cable tension. Use a second person (minimum) for assistance.

Do not over-tighten the adjustment nut. Overtightening can damage the handle assembly. When you have finished adjusting the tension, snug the nut tight.

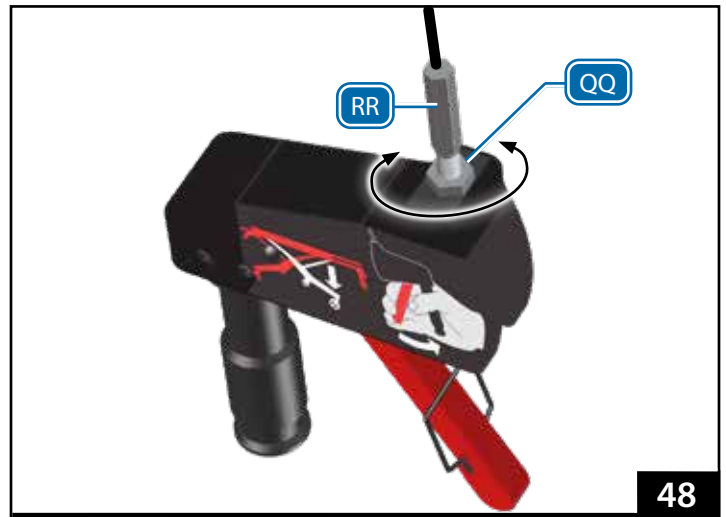

## 6.16 Adjusting the Oxygen Cylinder Holder

The oxygen cylinder holder (SS, Figure 49) allows supplementary oxygen to be carried on the cot. The holder adjusts to fit various oxygen cylinders. Remove the holder from the telescoping frame to adjust the mount positions or to remove the cylinder-fastening straps for cleaning. To remove the holder:

1. Raise the backrest.
2. Extend the telescoping frame.
3. Remove any oxygen cylinders attached to the holder.
4. Use a 4 mm hex wrench to remove the short screw (TT) from the four corners of the oxygen cylinder mount. Retain the screws.
5. Remove the oxygen cylinder mount and all washers
  - 4 small washers (UU)
  - 4 large washers (VV)
  - 4 rubber washers (WW)

### NOTICE

Do not operate the cot without the oxygen cylinder holder. The holder must be attached to provide structural support for the telescoping frame.

The oxygen cylinder holder must be detached from the telescoping frame to remove the cylinder-fastening straps for cleaning.

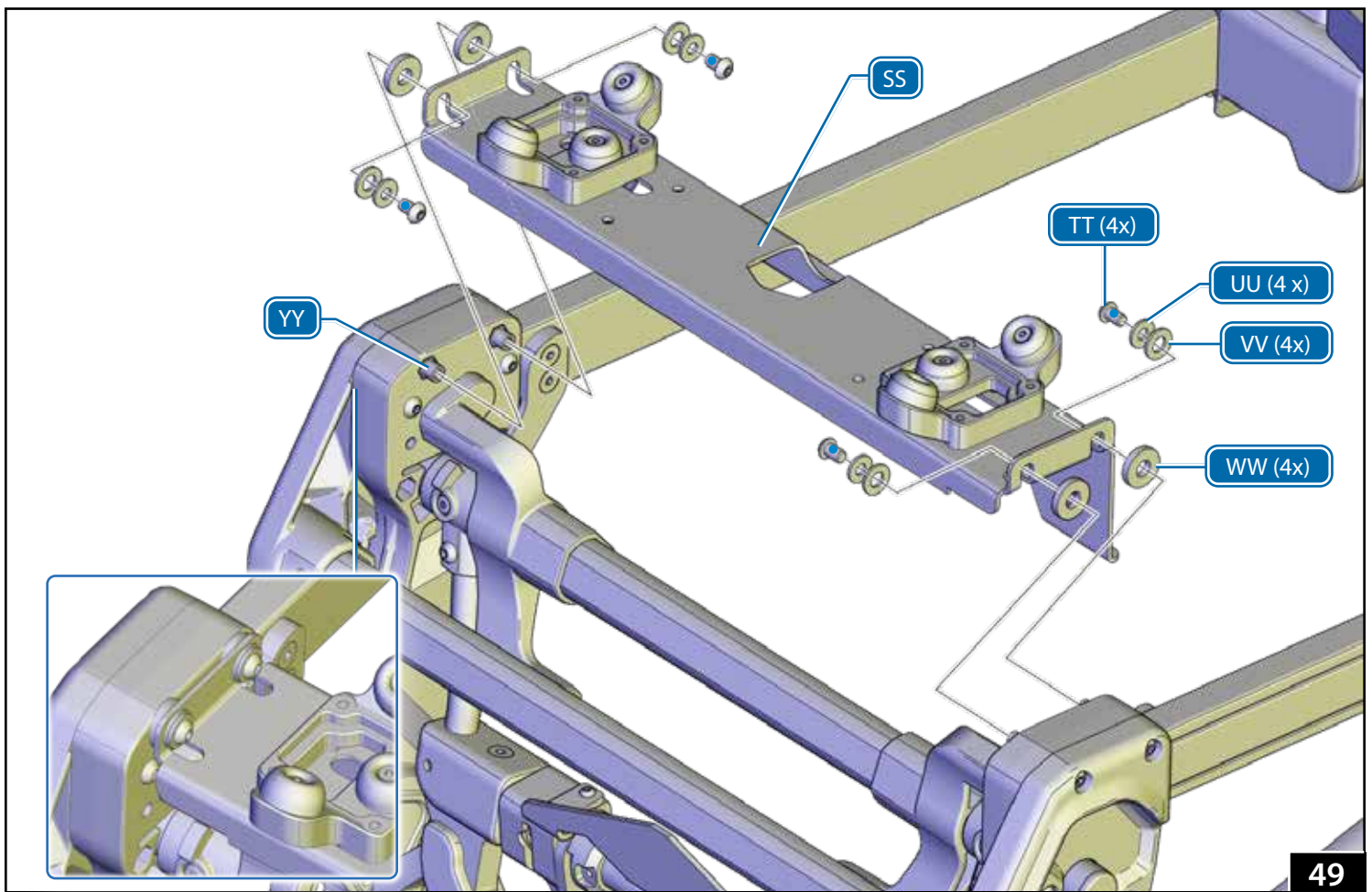

49

### ADJUSTING THE HOLDER

1. Use a 3 mm hex wrench to remove the four mount screws from beneath each mount (XX, Figure 50). Retain the mount screws.
2. Align the mounts as needed based on the size of the oxygen cylinder bottle (Figure 51).
3. Lay the cylinder fastening straps across the assembly, with the D-rings facing the cot control end and with the strap between the mounting holes for the selected bumper mount location (Figure 50 inset).
4. Prepare the 8 mount screws (XX) and receiving threads in the mounts:
  - Clean the threads of the screws, plus the receiving threads in the mounts with acetone or an appropriate threadlocker cleaner/primer (not supplied). Allow the threads to dry completely.
  - Apply 1 drop of removable threadlocker (not supplied) to the threads of each screw. Install the screws immediately. Wipe off any excess threadlocker.
5. Use a 3 mm hex wrench to install and tighten four mount screws into each mount (Figure 50).

### INSTALLING THE HOLDER

1. Prepare the 4 short screws and receiving threads in the hex spacers (TT, Figure 49 on page 42):
  - Clean the threads of the screws, plus the receiving threads in the hex spacers (YY) with acetone or an appropriate threadlocker cleaner/primer (not supplied). Allow the threads to dry completely.
  - Apply 1 drop of removable threadlocker (not supplied) to the threads of each screw. Install the screws immediately. Wipe off any excess threadlocker.
2. Place a rubber washer (WW) on each hex spacer (YY, Figure 49, page 42).
3. Insert the oxygen cylinder mount (SS) over the four hex spacers. Confirm the mount is properly seated on the hex spacers.
4. Place one small washer (UU) and one large washer (VV) on each short screw and insert the screws through the oxygen cylinder mount and into the hex spacers (Figure 49 on page 42).
5. Use a 4 mm hex wrench to tighten the short screws.
6. Confirm the oxygen cylinder mount holds the cylinder securely. See page 23.

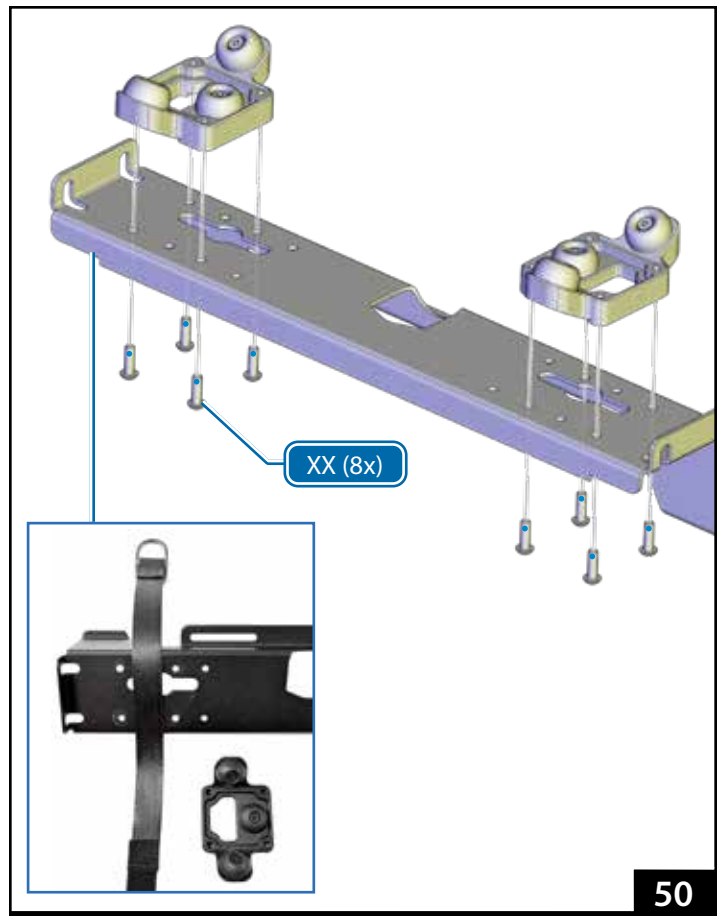

50

### NOTICE

Allow threadlocker to dry for a minimum of one hour before using the cot. Full cure time is 24 hours.

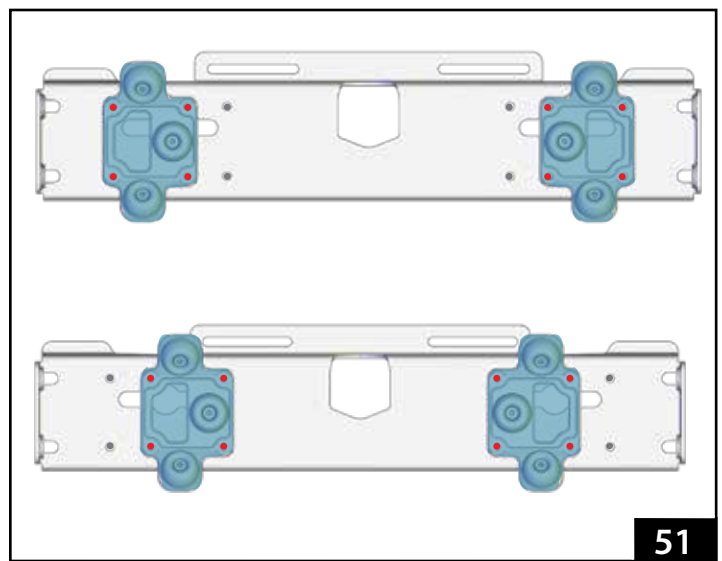

51

## 7 - INITIAL SETUP

### 7.1 Ambulance Information

The ambulance bumper extension must not exceed 13" (330 mm). The patient compartment must have a level floor large enough for the fully lowered cot, and a Ferno® iN|LINE® fastening system installed.

### 7.2 Accessories

Before placing the cot in service, assign appropriate personnel to install any accessories shipped with the cot. Keep accessory users' manuals with this manual for future reference. To order accessories, see page 46. For additional free manuals, contact Ferno (page 2).

### 7.3 Charge and Install the Battery

Immediately charge the battery upon receipt. Use only the provided battery charger or an ICS-powered fastening system (Figure 52).

The charger is compatible with standard household electricity and is supplied with an input cable for your country.

For complete information, see page 16, page 17, or the supplied charger and battery manuals.

### 7.4 Set the Loading Height

The user can set the cot so it stops automatically at the proper loading height for the assigned ambulance.

Be aware: The user-set loading height cannot be set when the cot is at the factory-set maximum transport height or maximum height.

To set or change the loading height:

1. On a level surface, raise or lower the cot until the loading wheels roll directly onto the ambulance floor (Figure 53). Confirm the loading wheels are resting on the ambulance floor, the safety bar is engaged with the safety hook, and the loading-leg wheels have not lifted off the ground.
2. Press the Mode-Select button four times to enter the set load-height mode (Figure 53 inset). See "Mode-Select Button" on page 18.
3. Press and hold **+** to set the loading height before the 15-second countdown timer expires. When pressed, a new 5-second timer will appear on the display. Continue holding **+** until the 5-second timer expires.
4. Turn the power switch OFF and then ON. See "Power Switch" on page 14.
5. Retract and extend the legs to verify the cot stops at the new loading height. Test loading and unloading the cot with the ambulance.

#### WARNING

Attaching improper items to the cot can cause injury.  
Use only Ferno-approved items on the cot.

#### NOTICE

Loose items and debris on the patient compartment floor can interfere with locking the cot into the iN|LINE. Keep the patient compartment floor clear.

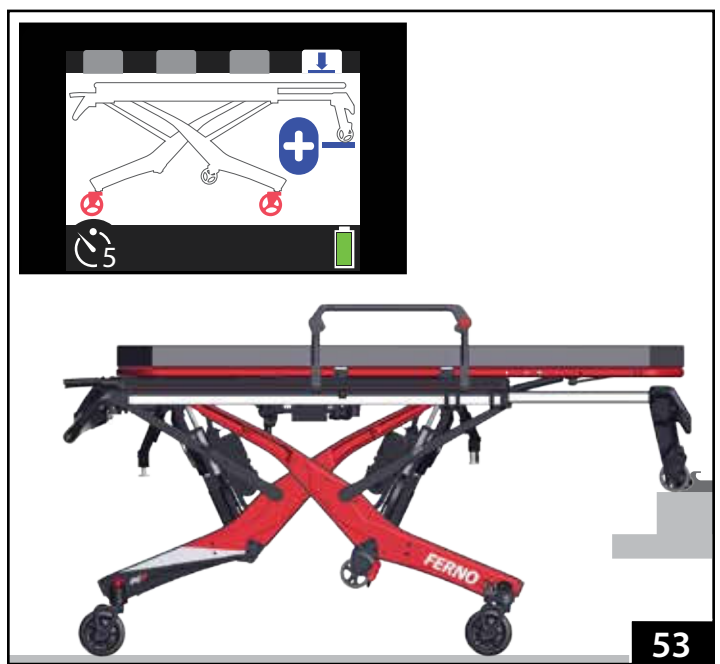
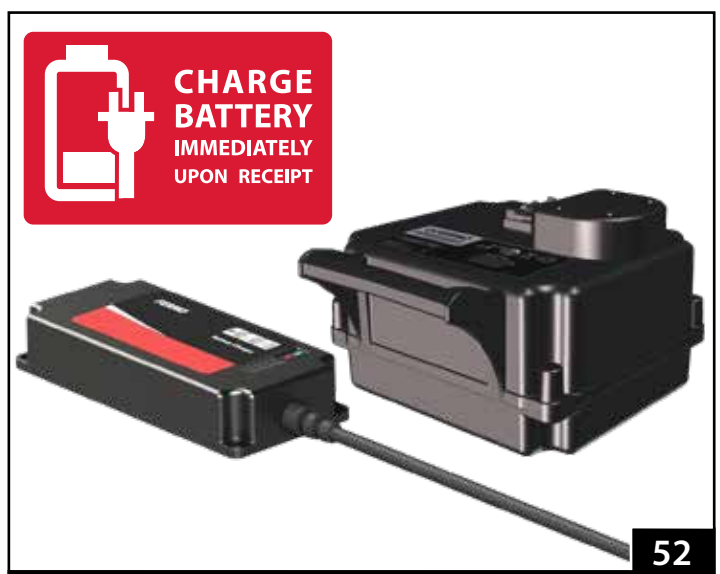

## 8 - TROUBLESHOOTING

### 8.1 General Troubleshooting

Source	Inspection Points	Checkpoints
Shore Power	Power outlet, fuse breaker, cables, connectors.	Confirm shore line provides proper voltage power. Re-set any tripped fuse breakers. Confirm cables and connectors are in good working condition and power is ON.
Inverter	Switches, fuse breaker, inverter type.	Confirm inverter power switch is ON. Some vehicles have switches in both the front and rear of the vehicle. Re-set any tripped fuse breakers. Confirm inverter has automatic switching between shore and vehicle power.
Ferno ICS	Power ON, charger, cables, contacts.	Confirm power to the charger is ON/powerd. Inspect the charger for error status (unplug and plug in again to re-set). Check wiring for damage and connectors for secure fit. Check metal ICS contacts on fastening system and cot for corrosion or misalignment.

### 8.2 Status Indicators

Color-coded status indicators alert the operator to safety or functional issues. There priority levels are: no priority, low, medium, and high. High-priority codes are red; all others are yellow. If a safety issue occurs, a warning triangle is displayed next to the error code. For service, see "Parts and Service" on page 46.

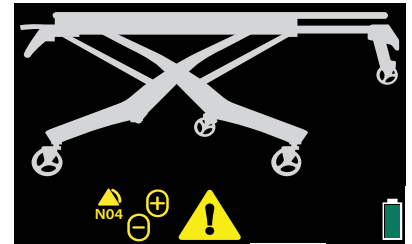

Icon	Meaning	Solution
	Button pressed longer than maximum time allowed, or both buttons being pressed at the same time.	<ol style="list-style-type: none"> <li>1) Release the button(s).</li> <li>2) Use non-powered operation to complete the transport.</li> <li>2) Possible stuck button. Disconnect top or bottom button set to locate fault and replace.</li> <li>3) Possible wiring issue. Continue Troubleshooting.</li> </ol>
	Auto-equalize problem due to leg obstruction, unequal weight distribution, or load exceeds the load capacity.	<ol style="list-style-type: none"> <li>1) Using caution, clear the leg obstruction or redistribute the weight.</li> <li>2) Use additional help to provide lift-assistance, or use direct power.</li> </ol>
	Battery charging issue.	<ol style="list-style-type: none"> <li>1) Possible battery fault. Swap for a different battery.</li> <li>2) Check the ICS for power; check contacts are clean.</li> <li>3) Charge battery on a wall charger (not through ICS). Check if problem is corrected.</li> </ol>
	Improper charge voltage (voltage too high).	Verify the connections between the cot, ICS, and ambulance power supply. The ICS or charger may be plugged into an outlet providing an incorrect power voltage.
	Battery over-temperature.	<ol style="list-style-type: none"> <li>1) Swap for a different battery or use non-powered operation to complete the transport.</li> <li>2) Allow time for the battery to cool.</li> </ol>
	Actuator motor overheated. The actuators are deactivated until the motor cools.	<ol style="list-style-type: none"> <li>1) Use non-powered operation to complete the transport.</li> <li>2) Allow time for the motors to cool. Check wiring for damage.</li> </ol>
	One or both cables routed from the control box to each actuator is disconnected or damaged.	Re-connect the cable(s); check wiring for damage.
	With or without weight on the cot, the legs are not moving at the proper speed. Load exceeds the load capacity, or there is an obstruction in the legs.	<ol style="list-style-type: none"> <li>1) Using caution, clear the leg obstruction or redistribute the weight.</li> <li>2) Use additional help to provide lift-assistance, or use direct power.</li> <li>3) Lubricate the slider rails. See "Lubricating the Cot" on page 38.</li> </ol>
	Communication error.	<ol style="list-style-type: none"> <li>1) Use direct power to complete the patient transport.</li> <li>2) Inspect all wiring between the control box, display, and actuators, including wires that are routed along the main frame.</li> </ol>
	Patient-surface above maximum safe transport height longer than 30 seconds. Display shows red patient surface and warning triangle.	Audible alarm sounds (pattern of 2+3 beeps); + button is disabled. Use - to lower the cot to a safe transport height.

## 9 - PARTS AND SERVICE

### 9.1 U.S.A. and Canada

In the United States and Canada, contact EMSAR, the only organization authorized by Ferno to manage, service, and repair Ferno products.



Telephone (Toll-free)	1.800.73.EMSAR
Telephone (Worldwide)	1.937.383.1052
Fax (Worldwide)	1.937.383.1051
Internet	<a href="http://www.EMSAR.com">www.EMSAR.com</a>

### 9.2 Worldwide

To order Ferno parts, and for professional repair, contact your Ferno distributor. Your distributor is the only agent authorized by Ferno to manage, service, and repair Ferno products.



#### WARNING

**Improper parts and service can cause injury. Use only Ferno parts and Ferno-approved service on the cot.**

**Modifying the cot can cause injury and damage. Use the cot only as designed by Ferno.**

Description	Part
Actuator pins, lower	090-6028
Backrest panel only	090-5972
Button, +/- (set)	090-6026
iNjX Battery	082-2480
AC-Input Charger-to-Battery Cable only	218-3008
iNjX Mattress	037-4904
iNjX Oxygen cylinder mount	090-5963
iNjX Oxygen cylinder mount bumpers (6)	090-5964
Safety bars (loading-end and intermediate)	090-5981
Safety-bar release lever	090-5985
Seat frame complete	090-5971
Seat panel only	090-6027
Shock frame complete	090-5968
Shock panel only	090-5969
Wheel, 6" (152 mm) solid (standard, each)	090-6031
Wheel, 6" (152 mm) trispoke (old version, set/4)	090-6093
Wheel, loading	090-5962
Wheel lock pedal	090-5960

#### FASTENING SYSTEM PARTS

Description	Part
Universal Floor Plate w/iNjLINE Adapter	080-0642
Universal Floor Plate Only	080-0643
ICS DC with Cabinet Charger	056-7083
ICS Conversion Kit (AC to DC power)	082-2507
iNjLINE 86" Stat Trac Mounts, DC	ILFS86STDC
iNjLINE 86" Universal Floor Plate Mounts, DC	ILFS86UFPDC
iNjLINE 95" Stat Trac Mounts, DC	ILFM95STDC
iNjLINE 95" Universal Floor Plate Mounts, DC	ILFM95UFPDC
iNjLINE 102" Stat Trac Mounts, DC	ILFL102STDC
iNjLINE 102" Universal Floor Plate Mounts, DC	ILFL102UFPDC
Stat Trac Floor Block (2) for iNjLINE-86"	056-7056
Stat Trac Floor Block (3) for iNjLINE-95" or iNjLINE-102"	056-7058

## 10 - ACCESSORIES

Ferno offers a full line of accessories approved for use with the cot. Follow all instructions in accessory users' manuals. Keep the instructions with this manual.

When using accessories, be aware of any special considerations such as doorway heights and widths, or other factors which may be affected by the addition of the accessory/accessories to the cot. Contact Ferno Customer Relations (page 2) or your Ferno distributor for cot information.



#### WARNING

**Attaching improper items to the cot can cause injury. Use only Ferno-approved items on the cot.**

Description	Part
iNjX Charger for USA, w/adapter	082-2463
iNjX Charger for United Kingdom w/adapter	082-2464
iNjX Charger for Europe w/adapter	082-2465
iNjX Charger for Australia w/adapter	082-2466
iNjX Equipment Holder, backrest panel version	082-2451
iNjX IV pole, 3-stage	082-2535
iNjX Mattress	037-4904
iNjX Side Lift Handle (pair)	FWESLH
iNjX Storage Net, telescoping frame	082-2453
iNjX SX - Surface Xtender (pair)	FWESX
iNjX Fold-down sidearms (pair)	082-2526
iNjX Backrest-mounted sidearms (pair)	082-2527
PacRac+ Equipment Platform	FWEPFIT
Patient Shield	082-2097
Pedi-Mate Pediatric Restraint	031-3778
Pedi-Mate, Pedi-Pal, NeoMate iNjX Adapter	082-2481
Restraint, Shoulder/Waist	037-4890
Restraint, Shoulder (only)	031-4114
Leg Restraint, Model 430, 2 piece, 5' (1524 mm) black	031-3892



Aviation

---

Military

---

Mortuary

---

EMS

---

Rescue

---