



TECHNIMOUNT
SYSTEM™

BRACKET PRO SERIE® 105

MOUNTING SYSTEM FOR ENVE®/REVEL® VENTILATOR



FEATURES



SAE J3043
Certified and
FAA Certification
in Process



Robust and
Lightweight Design
with Dual Disc
Options for
Installation



High-Density
Aluminum



Silver-Anodized
Finish for Scratch/
Corrosion Resistance



CNC Mechanical
Precision
Manufacturing



Compatible with Technimount's
Safety Arm System



Compatible with
Technimount's Products



Compatible with Technimount's
Universal Standard Base and
Extended Bases

BENEFITS



Offers Security
to Patient
and Crew



Reduces Risk of
Damage or
Replacement of
Medical Equipment



Easy to Install and
Integrity of Medical
Device Respected



Easy Access
to all Connectors
Functionalities of
Medical Device



Universal Use and
Compatibility with
all Technimount
Systems

BRACKET PRO SERIE® 105

The Bracket Pro Serie 105 is designed to secure and give you fast and flexible access to the EnVe/ReVel ventilator from Vyaire®. This robust mounting bracket is made with high-density aluminum with a small anti-rotation disc on the back for vertical support, and a standard bottom disc, providing 2 options for installation, wall and surface.

It complies with the highest industry safety standards for the transport of medical equipment, SAE J3043.

FLEXIBILITY WHERE IT MATTERS MOST

When inserted into the Technimount Standard Surface Base, it allows for a 360-degree rotation of the medical device while securely locked. The quick release mechanism helps to deploy the unit almost instantly allowing users to easily access the unit with minimum effort in times of emergency.



Hospital



Ambulance



Stretcher



Military

TECHNICAL SPECIFICATIONS

Product Name	Bracket Pro Serie® 105
Compatibility Model	EnVe /ReVel Ventilator from Vyaire
Environment of Usage	Hospital - EMS (Ground & Air) - Military
Device Section Material	High-Density Aluminum with Silver-Anodized Finish
Disc Section Material	Aluminum Structure with Stainless Steel Insert and Peek Cushions
Temperature of Usage	- 35° C @ 45° C (Direct Conduction)
Impact Resistance	(30 G) Plus 10% Safety Factor, SAE J3043 Certified, FAA Certification in Process
Installation Concept	Encapsulated (four sides); no Direct Screw on the Device
Product Size	Width 12 in, Depth 6.65 in, Height 11.95 in
Weight	Device Section Only: 6.1 lbs
Rotation	<ul style="list-style-type: none"> • 360° with Constant Locking Mechanism (Standard Surface Base) • 15° Both Sides with Constant Locking Mechanism (Extended Surface Base)
Positioning Installation	<ul style="list-style-type: none"> • Universal Surface Base or Micro Base for Vertical Installation
Features	<ul style="list-style-type: none"> • Compatible with Technimount Stretcher Safety Arm® System • Compatible with Technimount Standard and Extended Surface Bases • Compatible with Technimount Safety MD Transporter • Full Access to Connectors, Exhaults, Intake and all the Functionalities for the Medical Device
Part Number	Bracket Pro Serie™ 105 <ul style="list-style-type: none"> • 1400-10-BDV - EnVe Bracket - Device Section Only • 1400-00-BDV - EnVe Complete Assembly (Bracket and Standard Surface Base)

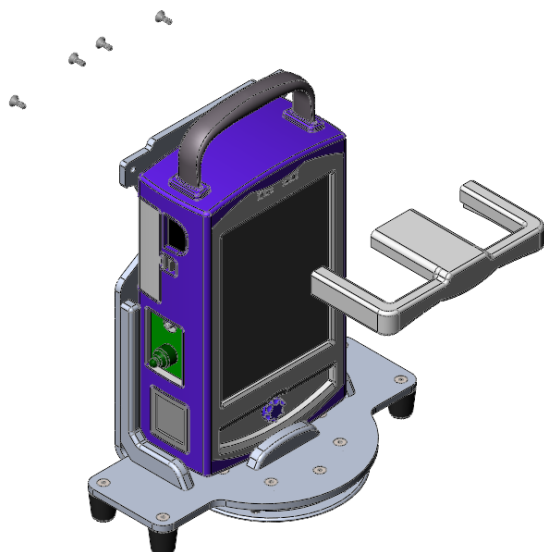

EnVe/ReVel Bracket Encapsulation Process

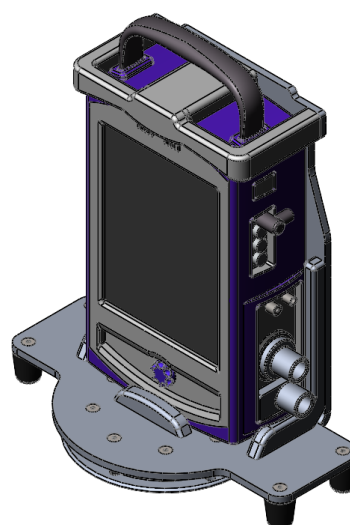

EnVe/ReVel Bracket with Device Installed

YOUR SAFETY IS OUR PRIORITY

When it comes to air and ground ambulance transport, patient and crew safety is the main concern. Providing safe transport not only applies to the vehicle or aircraft itself but also to the ability to effectively secure medical equipment.

Having robust and certified mounting systems can help avoid costly repairs, complete replacement of equipment and possible injuries to patients and crew.



ABOUT TECHNIMOUNT

Technimount designs and develops mounting solutions for different medical equipment such as defibrillators, ventilators, and pumps or other devices, in hospital, EMS, or military environments.

Technimount is the only manufacturer to have a universal mounting system that can fit on multiple brands, models, and applications of portable medical equipment for ambulances, stretchers, and hospital environments.

**SAFETY AND FLEXIBILITY
WHERE IT MATTERS MOST**

© Copyright 2019 Technimount System – All Rights Reserved
1. EnVe / ReVel is a registered trademark of Vyaire
Bracket Pro Serie is a registered trademark of Technimount System

technimount.com

