



**TECHNIMOUNT**  
SYSTEM™

# **SAFETY ARM SYSTEM™**

## USER GUIDE



# COPYRIGHT

---

Copyright Technimount System, Subsidiary of Technologies CGC Inc. 2019. All Rights Reserved. No part of this publication may be reproduced, transmitted, transcribed, stored in a retrieval system, or translated into any language in any form or by any means without the written permission of Technimount System or its affiliate companies.

## Trademark Attributions

Safety Arm System is a Trademark of Technimount System.

The Safety Arm System is patented, under reference # 62/909-408

Stryker® stretcher models and numbers are registered trademarks of Stryker.

Technimount System does not have a commercial relationship with Stryker. Stryker does not promote or sell Technimount Products.

In order to ensure continuous improvements to our products and services, we invite you to communicate your comments to our Customer Service Department at [customerservice@technimount.com](mailto:customerservice@technimount.com). See Contact Information.

# CONTACT INFORMATION

---

## CORPORATE HEADQUARTERS

### TECHMOUNT SYSTEM

Customer Service or Technical Support  
3770 Jean Marchand Street, Suite 100  
Quebec (QC) G2C 1Y6  
Canada

[www.technimount.com](http://www.technimount.com)

T + 1 581.998.9820

F + 1 855.339.6351

[customerservice@technimount.com](mailto:customerservice@technimount.com)

[techsupport@technimount.com](mailto:techsupport@technimount.com)

### NOTE:

Please have the serial number of your Technimount product available (as shown in the figure below) when calling Technimount Customer Service or Technical Support. Include the serial number in all written communications.

### SERIAL NUMBER LOCATION

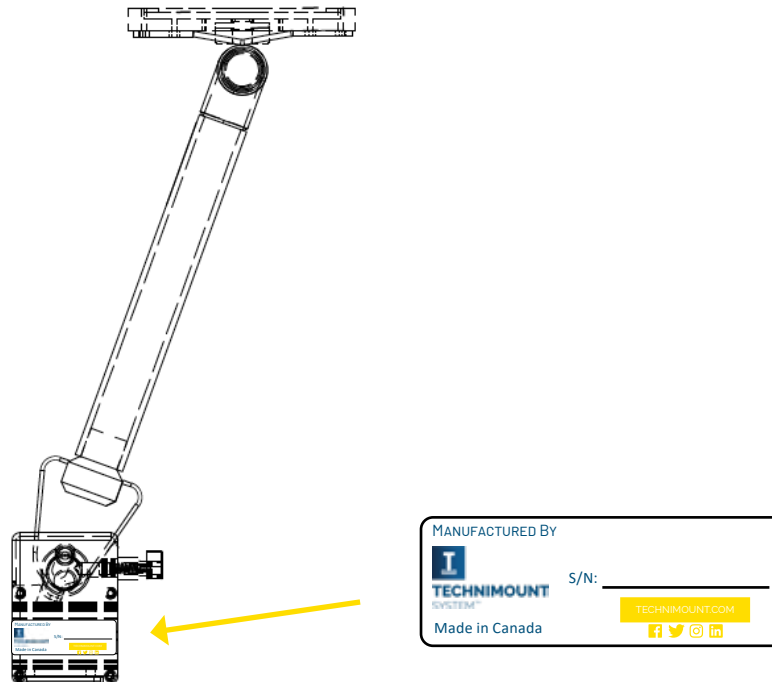

[Return To Table of Contents](#)

# TABLE OF CONTENTS

---

<b>COPYRIGHT .....</b>	<b>2</b>
<b>CONTACT INFORMATION.....</b>	<b>3</b>
<b>INTRODUCTION .....</b>	<b>6</b>
PRODUCT DESCRIPTION .....	6
INTENDED USE OF THE PRODUCT .....	6
SYMBOLS AND DEFINITIONS .....	7
WARNING / CAUTION / NOTE.....	8
IDENTIFICATION OF COMPONENTS.....	9
<i>LOCK PIN</i> .....	9
<i>SAFETY PIN</i> .....	9
<i>CLAMP BLOCK</i> .....	10
<i>SAFETY ARM</i> .....	10
<i>HARDWARE KIT FOR THE SAFETY ARM</i> .....	11
PRODUCT OPTIONS AVAILABLE .....	11
INSTALLATION RELATED TO THE STRYKER POWERLOAD STRETCHER.....	11
SPECIFICATIONS.....	12
<b>PRODUCT INFORMATION .....</b>	<b>15</b>
PRODUCT ILLUSTRATION WITH OTHER EQUIPMENT ON STRETCHER .....	15
<i>INSTALLATION OVERVIEW</i> .....	16
<b>SUMMARY OF SAFETY PRECAUTIONS .....</b>	<b>17</b>
WARNING/CAUTION/NOTE .....	17
<b>INSTALLATION GUIDE .....</b>	<b>20</b>
REMOVING PACKAGING FOR INSTALLATION .....	20
TOOLS REQUIRED FOR INSTALLATION.....	20
COT/STRETCHER ORIENTATION DIAGRAM .....	21
PREPARING THE COT/STRETCHER FOR INSTALLATION .....	22
<i>REMOVING THE IV POLE OR CHANGING THE SIDE OF THE IV POLE</i> .....	22
SAFETY ARM SYSTEM INSTALLATION.....	25
<i>POSITION ON THE COT/STRETCHER</i> .....	25
<i>PATIENT RIGHT AND LEFT INSTALLATION</i> .....	25
<i>POSITION ON THE COT/STRETCHER (CONTINUED)</i> .....	26
<i>PATIENT RIGHT INSTALLATION</i> .....	26
<i>INSTALLING THE CLAMP BLOCK (PATIENT RIGHT)</i> .....	27
<i>INSTALLING THE STANDARD SURFACE BASE ONTO THE SAFETY ARM SYSTEM UPPER PLATE</i> .....	32
<b>OPERATION CAUTION AND WARNING .....</b>	<b>34</b>
<b>OPERATION GUIDE .....</b>	<b>35</b>
GENERAL OPERATING GUIDELINES.....	35
<i>RECOMMENDED LIFTING TECHNIQUES</i> .....	35
<i>RECOMMENDED HANDLING POSITIONS</i> .....	36
OPERATING THE SAFETY ARM SYSTEM .....	37
<i>LOWERING THE SAFETY ARM</i> .....	38
<i>RAISING THE SAFETY ARM</i> .....	39
<i>REMOVING THE SAFETY ARM</i> .....	40
<b>SAFETY ARM SYSTEM OPTIONS .....</b>	<b>42</b>
STRYKER POWERPRO OPTIONS .....	42
STRYKER MX-PRO OPTIONS.....	42

# TABLE OF CONTENTS

---

<b>MAINTENANCE GUIDE.....</b>	<b>43</b>
CLEANING THE SAFETY ARM SYSTEM .....	43
CLEANING PROCESS.....	43
CLEANING SOLUTIONS.....	43
REMOVAL OF IODINE COMPOUNDS .....	44
PREVENTIVE MAINTENANCE.....	44
LUBRICATION .....	44
INSPECTION PROCESS AND SCHEDULE.....	45
PREVENTIVE MAINTENANCE PROGRAM.....	45
INSPECTION AND MAINTENANCE RECORD.....	46
TRAINING RECORD.....	47
REPLACEMENT PARTS.....	48
<b>WARRANTY .....</b>	<b>49</b>
WARRANTY POLICY .....	49
LIMITED RESPONSIBILITY AND WARRANTY.....	49
WARRANTY OPTIONS .....	50
THREE WARRANTY OPTIONS FOR TECHNIMOUNT PRODUCTS.....	50
INTERNATIONAL WARRANTY CLAUSE .....	50
<b>RETURN POLICY .....</b>	<b>51</b>
RETURN OF MERCHANDISE .....	51
PRIOR TO 30 DAYS .....	51
PRIOR TO 45 DAYS .....	51
PRIOR TO 60 DAYS .....	51
RETURN MERCHANDISE AUTHORIZATION .....	51
DAMAGED MERCHANDISE .....	51

# INTRODUCTION

---

This User Guide is designed to assist you with the installation, operation and maintenance of the Technimount Safety Arm System™ 500. Please read this User Guide thoroughly before using this equipment. To ensure the safe operation of this equipment, it is recommended to train staff prior to use.

## PRODUCT DESCRIPTION

The Technimount Safety Arm System® 500 is a mounting system for the stretcher that consists of a platform, mounted on a top-down movable arm, installed with a clamp block on the stretcher frame. It is designed to support and transport portable medical devices with a maximum weight of 45 lbs. in pre-hospital and hospital environments. The medical device can be removed and stored safely when not in use. When the arm is used in emergency vehicles with a cot/stretcher, it has two positions, upper locked position for transport and the lower position for loading/unloading of the patient on the stretcher. The red safety pin must be pulled to lower or raise the arm.

The Safety Arm System™ is equipped with a safety locking mechanism to secure the position of the arm during transport. When not in use, the arm can be lowered for loading and unloading of the patient. The arm is also equipped with a side locking pin with a finger ring handle in order to secure the arm into the clamp block attached to the stretcher. In case of emergencies, the side locking pin can be removed in less than 5 seconds, by releasing or pulling back the fixed safety locking mechanism. Once removed, raise the Safety Arm to disengage it from the clamp block.

Once combined with the surface base mounting system (Bracket Pro™ Serie) it allows the medical crew to see and use the unit during transport as well as during patient loading and unloading.

## INTENDED USE OF THE PRODUCT





The Safety Arm System™ 500 is a secure mounting system for medical devices, designed to be installed on a stretcher (Stryker Stretchers MX-Pro and PowerPro models). The mount is intended to support and transport medical equipment during a medical intervention of a traumatized, an ambulatory or non-ambulatory patient (including infants, children and adults).

The upper position (or locked position) is designed to incorporate the use of the medical device while transporting the patient and performing normal tasks by medical personnel. The lower position (or unlocked position) is designed to assist with loading or unloading of the patient onto/from the stretcher, and it is not designed to be used during the movement or transport of the stretcher.

Once the arm is in the upper position (or locked position), it facilitates the safe transport of associated medical equipment (i.e. defibrillator and/or pumps) in emergency vehicles. The use of the Safety Arm System™ 500 was developed to be used on an ambulance stretcher and intended for front-line responders who have received the training necessary to operate the System in the field. The expected service life of the Safety Arm System is 5 years, or more, depending upon use.



The Safety Arm Systems are intended for transport purposes only. They are not intended for more than one unit nor any additional equipment attached to the arm.

## SYMBOLS AND DEFINITIONS

SYMBOL	DESCRIPTION
	Caution, special attention is required. Consult accompanying documents
	Safe working load symbol
	Pinch Point
	Load balance symbol

## WARNING / CAUTION / NOTE

The word warning, caution, or note carry special meaning and should be carefully reviewed.

	<p><b>WARNING</b></p> <p>Alerts the reader about a situation which, if not avoided, could result in death or serious injury. It may also describe potential serious adverse reactions and safety hazards.</p>
	<p><b>CAUTION</b></p> <p>Alerts the reader of a potentially hazardous situation, which, if not avoided, may result in minor or moderate injury to the user or patient or damage to the equipment or other property. This includes special care necessary for the safe and effective use of the device to avoid damage that may occur as a result of use or misuse.</p>
<p><b>NOTE</b></p>	<p>Provides special information about the product.</p>



## IDENTIFICATION OF COMPONENTS

### LOCK PIN

The Lock Pin is made of stainless steel with a finger ring. It is used to lock the Safety Arm System inside the clamp block. It goes through the clamp block and the bottom of the arm, locking the arm inside the clamp block.

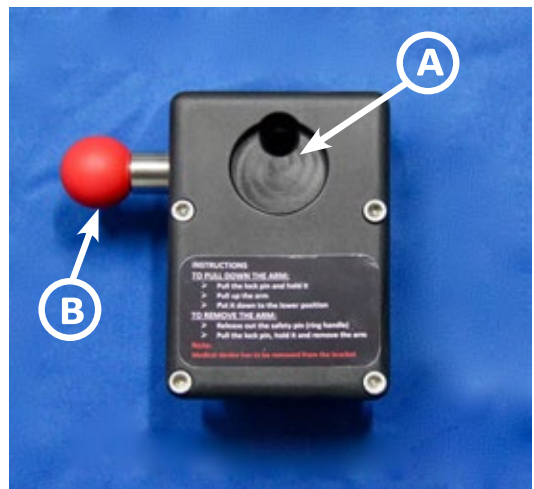

**FIGURE 1. LOCK PIN WITH FINGER RING**

### SAFETY PIN

The fixed safety pin is identified by the red round handle mechanism used for locking the arm in the upper position.

- a) Side Lock Pin Insert
- b) Safety Pin with red handle



**FIGURE 2. CLAMP BLOCK WITH SAFETY PIN INSERTED**

## IDENTIFICATION OF COMPONENTS (CONTINUED)

### CLAMP BLOCK

The clamp block is the two (2) part metal system attached on one side of the stretcher frame, in order to support and insert the arm. The two sections are attached with four (4) hexagon socket pan head screws; as shown in picture 3 and 4.



FIGURE 3. CLAMP BLOCK BEFORE ASSEMBLY



FIGURE 4. PICTURE 4: CLAMP BLOCK AFTER ASSEMBLY

### SAEFTY ARM

The base mount (upper plate) is welded onto the safety arm as shown in picture 5. The yellow safety arm goes into the clamp block as shown in picture 4.



FIGURE 5. SAFETY ARM BASE MOUNT (UPPER PLATE) AND B) HARDWARE FOR INSTALLATION OF THE BASE TO THE PLATE



FIGURE 6. YELLOW SAFETY ARM

# INTRODUCTION

---

## HARDWARE KIT FOR THE SAFETY ARM

The hardware (screws, nuts and caps) are provided for the installation of the standard surface base on the upper plate.

1. 2 screws 10-32 x 1-3/4" Philips (star)
2. 2 screws 10-32 x 1-1/4" Philips (star)
3. 4 hexagonal nuts 10-32 x 3/8"
4. 2 hexagonal SS Caps 10-32



## PRODUCT OPTIONS AVAILABLE

1. The locking pin is available in red. Coloring of the stainless steel pin is achieved through a chemical process called anodization. Anodizing is an electrochemical process that converts the metal surface into a decorative, durable, corrosion-resistant, anodic oxide finish. Extremely durable, hard, and abrasion resistant. The coating does not peel or chip. Much harder surface than paint and powders.
2. The yellow color is the standard color for the Safety Arm System. Black is also available.
3. To install the IV Pole on the same side of the Safety Arm Stretcher, an IV Pro Adapter plate is required to support it. Contact Customer Service for more information, [customerservice@technimount.com](mailto:customerservice@technimount.com)

## INSTALLATION RELATED TO THE STRYKER POWERLOAD STRETCHER

- ✓ The spacer block is the shim installed under the "V" bracket on the cot/stretchers frame when a power load system is installed with the cot/stretchers. This bracket is NOT a Technimount part.

# INTRODUCTION

## SPECIFICATIONS

<b>Cot/Stretcher Brand and Model Available</b>	Stryker Cot/Stretcher
 <p>Note: Safe Working Load Safe Working Load indicates the sum of the medical device and accessory weight</p>	45 lbs
<b>Model</b>	Safety Arm System - 500
<b>Cot/Stretcher Compatibility</b>	ProXT, PowerPro, model 6085-6086, 6500 and 6506
<b>Part Number (Depending on Cot Model)</b>	500-00-XXXX
<b>Positions</b>	Upper and lower
<b>Material Manufacturing</b>	High-density aluminium
<b>Cot/Stretcher Installation</b>	Clamp box on side frame
<b>Positioning Installation</b>	Patient right side Patient left side
<b>Dimensions (Inches)</b>	
<ul style="list-style-type: none"> <li>▪ <b>Total Height - Upper Position</b></li> </ul>	18 <sup>7</sup> / <sub>8</sub> in
<ul style="list-style-type: none"> <li>▪ <b>Overall Length - With Clamp Block</b></li> </ul>	21 <sup>5</sup> / <sub>8</sub> in
<ul style="list-style-type: none"> <li>▪ <b>Cot/Stretcher (Frame) to Under Base Plate on Upper Position</b></li> </ul>	17 <sup>1</sup> / <sub>4</sub> in – Cot mattress up 10 in – Cot mattress down
<ul style="list-style-type: none"> <li>▪ <b>Cot/Stretcher (Frame) to Under Base Plate on Lower Position</b></li> </ul>	9 <sup>3</sup> / <sub>8</sub> in – with tubing 12 in – after the base plate
<b>Weight</b>	
<ul style="list-style-type: none"> <li>▪ <b>Arm Only</b></li> </ul>	3.8 lbs
<ul style="list-style-type: none"> <li>▪ <b>Clamp Block</b></li> </ul>	2.15 lbs
<ul style="list-style-type: none"> <li>▪ <b>Total System (Hardware Included)</b></li> </ul>	6.8 lbs
<b>Colors Available</b>	- Black - Yellow
<b>Angle of the Base Plate with the Arm</b>	70°

# INTRODUCTION

## SPECIFICATIONS CONTINUED

<b>Installation holes on Upper Base Plate</b>	4 holes
<b>Recommended Loading Position</b>	Lower
<b>Recommended Number of Operators</b>	2
<b>Surface Base Mount Compatibility</b>	Bracket Pro Standard and extended base
<b>Impact Resistance Testing</b>	30 G – 577 lbs
<b>Typical Mounting</b>	
<b>Clamp Block</b>	Clamp box mounting with 4 screws on side square frame
<b>Safety Arm</b>	Dual locking system <ul style="list-style-type: none"> <li>• Red handle safety pin to pull arm up or down</li> <li>• Lock pin for installation/removal</li> </ul>
<b>Installation Time</b>	~ 5 minutes
<b>Estimated Time to Remove Safety Arm</b>	Less than 5 seconds
<b>Standards for Testing</b>	SAE J3043

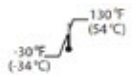
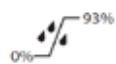
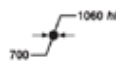
<u>ENVIRONMENTAL CONDITIONS</u>	<u>OPERATION</u>
Temperature	-30 °F (-34 ° C) to 130 °F (54 °C) 
Relative Humidity	
Atmospheric Pressure	

### CAUTION

- ✓ Any changes or modifications to the product will void the warranty.
- ✓ Technimount system reserves the right to change specifications without notice.

[Return To Table of Contents](#)

# INTRODUCTION

---

## NOTE

The Safety Arm System™ is designed to comply with Federal Specifications for the Star-of-Life Ambulance (KKK-A-1822) and SAE J3043. Patents on product currently pending.

Technimount hereby declares that this Safety Arm System™ (model 400-500) is in compliance with the essential requirements and other relevant provisions of the Directive 1999/5/EC and SAE J3043. A copy of the original declaration of conformity can be obtained by contacting Technimount System's Regulatory Affairs Department:

## TECHNIMOUNT SYSTEM

C/O: Regulatory Affairs

3770 Jean Marchand Street, Suite 100

Quebec (QC) G2C 1Y6

Canada

[info@technimount.com](mailto:info@technimount.com)

[www.technimount.com](http://www.technimount.com)

T + 1 581.998.9820

F + 1 855.339.6351

# PRODUCT INFORMATION

## PRODUCT ILLUSTRATION WITH OTHER EQUIPMENT ON STRETCHER



[Return To Table of Contents](#)

## PRODUCT ILLUSTRATION (CONTINUED)

### INSTALLATION OVERVIEW

Upper Position

Locked Position for  
Transportation

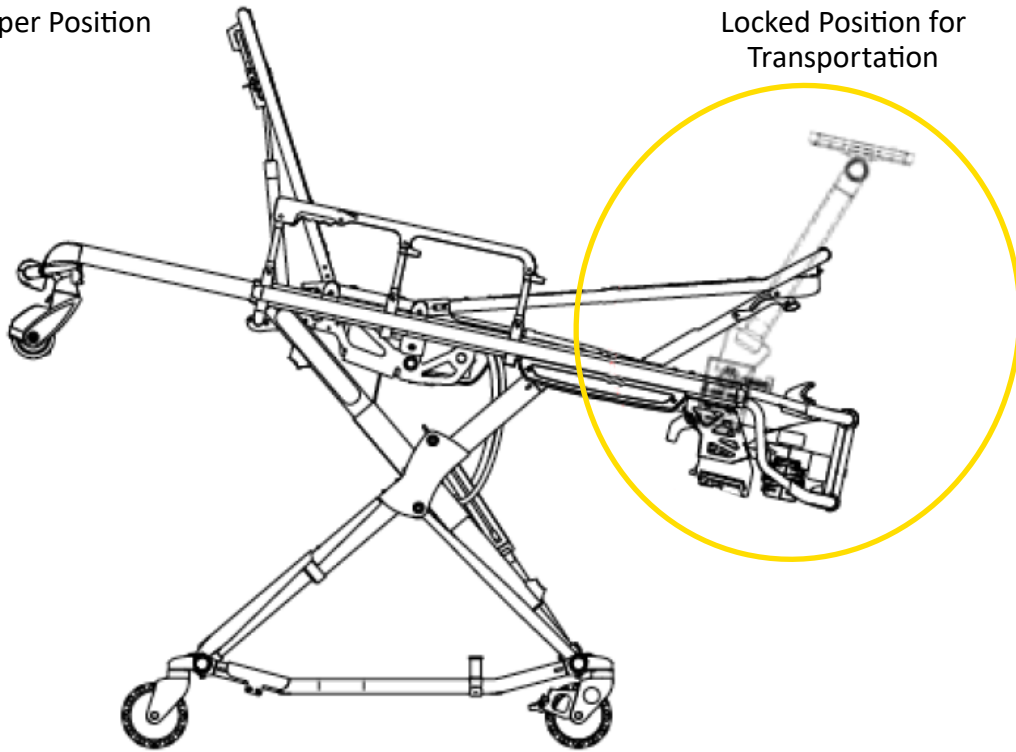

**FIGURE 7. SAFETY ARM SYSTEM INSTALLED ON COT**



# SUMMARY OF SAFETY PRECAUTIONS

---

## WARNING/CAUTION/NOTE

Carefully read and strictly follow all Warnings and Cautions listed in this manual. Servicing and maintenance should only be done by qualified personnel.

---

### WARNING

---

- ✓ Always hold the arm when you manipulate it.
- ✓ Always pull and hold the Safety Pin (red handle) until it reaches the final upper position (locked) or lower position (un-locked). Failure to do so can cause damage to the equipment.
- ✓ To avoid injury, hands should be clear of the black clamp block and arm pivot while loading and unloading the medical equipment or whenever changing height position of the arm with two or more operators.
- ✓ Improper usage of the Safety Arm System can cause serious injury to the patient or operator. Operate the arm only as described in this user guide.
- ✓ Do not modify the arm or any components of the system. Modifying the product can cause unpredictable operation resulting in injury to the patient or operator.
- ✓ It is the responsibility of the operator of the cot/stretchers to ensure that the Safety Arm System being used with Technimount products meets the installation specifications.. Injury may result if non-compatible products are used with Technimount System products.
- ✓ Do not attempt to operate the arm when it is loaded into a vehicle or in a very tight or narrow space.
- ✓ Failure to install the side Lock Pin (finger ring) can cause the arm to fall and may cause injury to the operator and may damage the product. Always secure the arm with the safety pin. Install and use the safety pin as described in this user guide.
- ✓ To avoid any injury, verify that the side safety pin has been pulled all the way through the clamp block before removing the arm from the cot/stretchers or lowering the arm to the unlocked position.
- ✓ Verify that the side safety pin (finger ring) is always pushed into the holes of the clamp block and the arm base is in the locked position. Regardless of how the arm is loaded or unloaded with a medical device, injury to the patient or operator and/or damage to the arm may occur.
- ✓ Practice changing arm positions (Transportation (Locked)/Loading & Unloading (Un-Locked) until operation of the product is fully understood. Improper use may cause injury to the operator.
- ✓ Always hold the arm securely near the bend (top of the arm) when changing positions from locked to unlocked. Failure to do so, can cause damage to the product and/or the cot/stretchers.
- ✓ Do not allow untrained staff to assist in the operation of the arm system. Untrained technicians/staff can cause injury to the patient or themselves.
- ✓ Do not sit on the tubular pole (arm), damage to the product could occur, and may result in injury to the patient or operator.
- ✓ Grasping the arm improperly can cause injury. Keep hands, fingers and feet away from moving parts. To avoid injury, use extreme caution when placing your hands near the tubular base (arm and clamp block) while raising or lowering the arm.
- ✓ Operators must be able to safely lift the total weight of the Safety Arm System (arm and medical device), and any items attached to the arm.
- ✓ Never use the arm when installed on the cot/stretchers in the lower or un-locked position, to open the rear vehicle door, or pull the cot/stretchers with the arm.
- ✓ Do not attempt to load the arm with the medical device in the lower or un-locked position. Loading a medical device onto the arm must be in the upper and locked position, if not installed properly, the medical device on the surface base may cause injury to the patient or operator and/or damage to the product.

[Return To Table of Contents](#)

# SUMMARY OF SAFETY PRECAUTIONS

## WARNING/CAUTION NOTE (CONTINUED)

### WARNING (CONTINUED)

- ✓ Do not attach restraints to the base tubular frame, the surface base, or any other place of the arm system. It may result in damage to the arm and/or result in injury to the patient or operator.
- ✓ Do not place any additional equipment or objects on the arm, other than the approved Technimount System device bracket for medical devices.
- ✓ Always reposition the arm with care, avoid any improper pushing or violent manipulation, as it may result in an unbalanced cot/stretcher and may cause injury to the patient or operator and/or damage to the product.
- ✓ To avoid the risk of patient injury or equipment damage, ensure that you properly mount and secure the defibrillator platform (bracket) to the arm's receiving surface base.
- ✓ To avoid the risk of patient injury or equipment damage, you must make sure that the disc attached to the bracket under the medical device is properly locked into the surface base prior to repositioning the arm.
- ✓ If you want to remove the arm from the system, make sure you remove the medical device from the surface base prior the operation, failure of removing it may result in damage to the product, or cause injury to the operator.
- ✓ Improper maintenance can cause injury or damage to the product. Maintain the Safety Arm System as described in this user guide. Use only Technimount approved parts and maintenance procedures. Using unapproved parts and procedures could cause unpredictable operation and/or injury and will void the product warranty.
- ✓ Failure to properly clean or dispose of corrosive products will increase the risk of premature damage and may cause injury to the patient or operator.
- ✓ Ensure proper hand placement on a high position on the tubular frame (pole). Hands should be clear of clamp block while loading and unloading the arm or whenever changing height position of the arm system with two or more operators.
- ✓ Do not adjust or change the position of the arm while you are walking or working with the cot/stretcher. Stay with the patient and control the arm at all times.

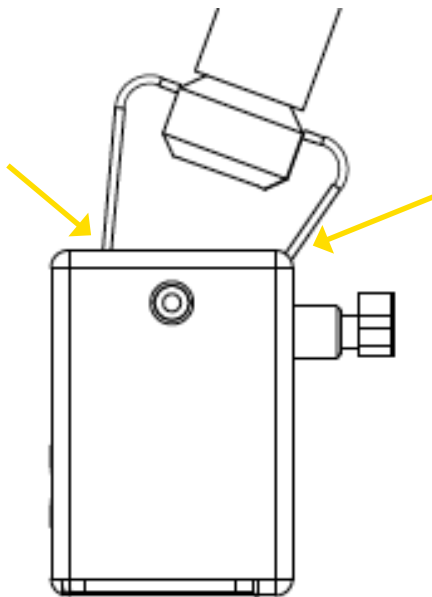

**FIGURE 8. SIDE VIEW OF THE CLAMP BLOCK AND ARM PIVOT**

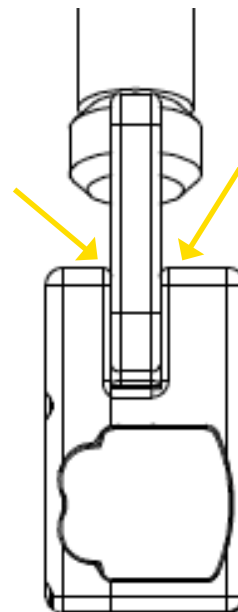

**FIGURE 9. SIDE VIEW OF THE CLAMP BLOCK AND ARM PIVOT**

# SUMMARY OF SAFETY PRECAUTIONS

---

## WARNING/CAUTION"NOTE (CONTINUED)

---

### CAUTION

---

- ✓ Certified technical personnel familiar with the cot/stretchers specifications should complete the installation of the clamp block. Refer to the cot/stretchers manufacturer's manual before installing the Safety Arm System and ensure that the installation of the Safety Arm System does not damage or interfere with the use of the cot/stretchers.
- ✓ Inspect regularly the clamp block and surface base for any issue and loose screws, bolts and nuts.

### NOTE

- ✓ Some cleaning products are corrosive in nature and may cause damage to the product if used improperly. If such products are used to clean Technimount equipment, the equipment must be rinsed with clean water and thoroughly dried following the cleaning. Failure to properly rinse and dry the Arm will leave a corrosive residue on the surface of the cot/stretchers, possibly causing premature corrosion of critical components.
- ✓ Installation of the Safety Arm System was designed to be placed on either side of the stretchers with the use of the right or the left Safety Arm System (patient right or left). When ordering, it is important to identify which side the Safety Arm is to be located. The Safety Arm System cannot be reversed as the clamp block has been designed for a specific side.
- ✓ A preventive maintenance program should be established for all Technimount equipment. Preventive maintenance may need to be performed more frequently, based on the level of use of the product. Close attention should be given to safety features (i.e.: safety pins, and attachment points).
- ✓ Failure to use authorized parts, and lubricants, etc., could cause damage to the arm and will void the warranty of the product.
- ✓ This user guide should be considered a permanent part of the Safety Arm System and should remain with the product even if the arm is subsequently sold.
- ✓ Always manipulate the arm at the lower position of the cot/stretchers, as much possible; high lever may unbalance the cot/stretchers with violent movement or unpredictable motion.

Technimount continually seeks advancements in product design and quality. Therefore, while this manual contains the most current product information available at the time of printing, there may be minor discrepancies between your arm system and this user guide. If you have any questions, please contact Technimount Customer Service or Technical Support at +1.581.998.9820.

# INSTALLATION GUIDE

---

## REMOVING PACKAGING FOR INSTALLATION

1. Unpack boxes and check all items for proper operation.
2. Ensure that all shipping and packaging materials have been properly removed from the product(s) prior to installation.
3. Identify all of the product components and hardware prior to starting the installation.
4. Some hardware or parts provided might not be applicable to the model of your cot/stretchers.
5. The Safety Arm System must work properly before it is put into service.
6. Refer to the identification of components at the beginning of this user guide if needed.

### NOTE

- ✓ Loose items or debris on the cot/stretchers can interfere with the operation of the Safety Arm System and cot/stretchers. Keep the cot/stretchers and the floor clear.

## TOOLS REQUIRED FOR INSTALLATION

Below are the basic tools required for installation. Other tools may also be needed. If you have any questions regarding the installation, or need assistance, please contact our Technical Support team at [techsupport@technimount.com](mailto:techsupport@technimount.com)



FIGURE 10. ALLEN KEY 3/16 IN



FIGURE 11. S2-T27 STAR BIT SCREWDRIVER



FIGURE 12. RUBBER HAMMER

### NOTE

- ✓ Electrical tools are not recommended for screwing into the cot/stretchers frame, as there is a potential risk of damage to the threads.
- ✓ During the installation process, Technimount System recommends the use of Blue Loctite 2400 to avoid premature loosening of screws during normal use. Put a few drops of Blue Loctite on each screw prior to installation.



# INSTALLATION GUIDE

---

## COT/STRETCHER ORIENTATION DIAGRAM

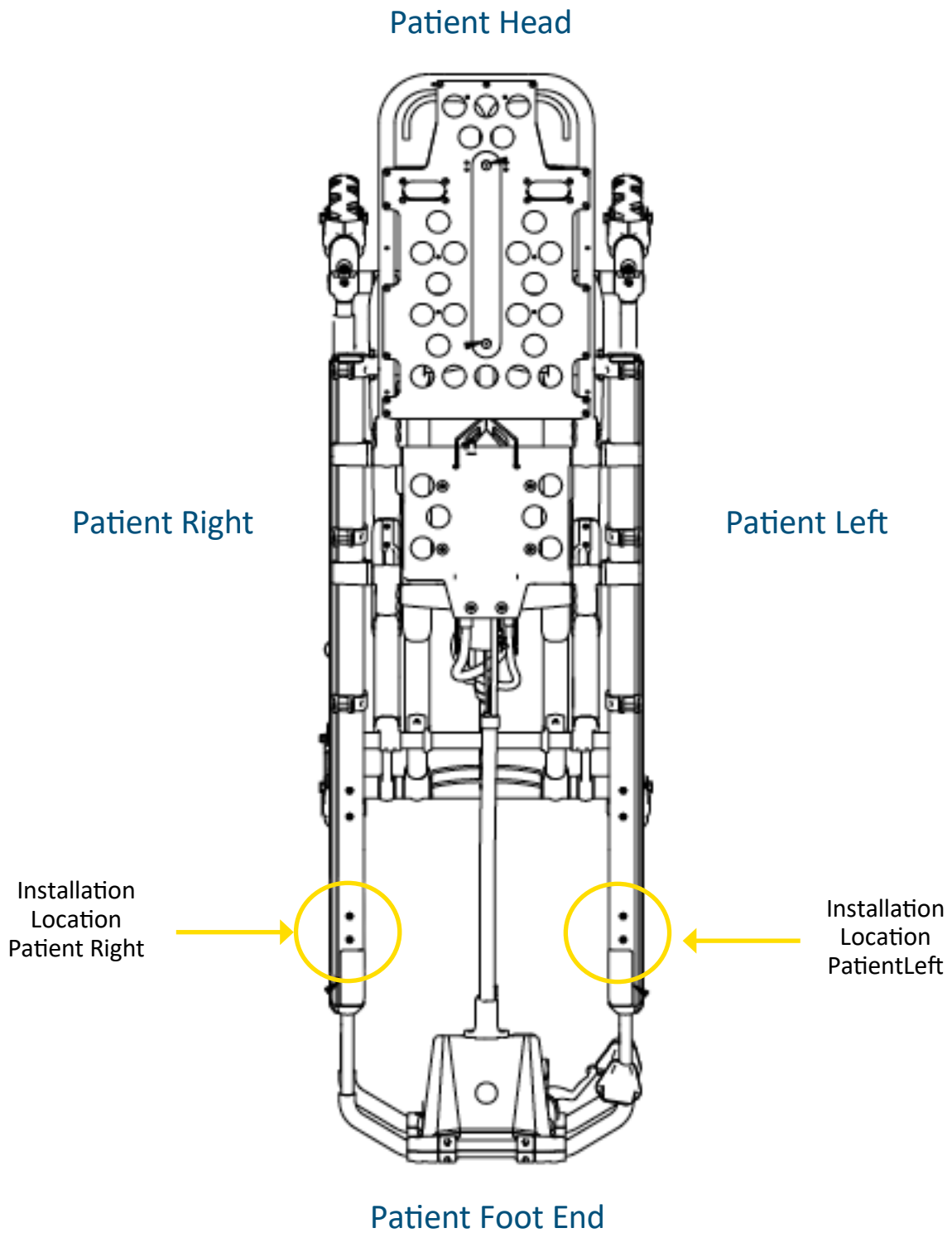

[Return To Table of Contents](#)

## PREPARING THE COT/STRETCHER FOR INSTALLATION

### [REMOVING THE IV POLE OR CHANGING THE SIDE OF THE IV POLE](#)

#### [NOTE](#)

- ✓ If the cot/stretchers has an IV pole located on the side you want to install the Safety Arm System, you will need to remove the IV Pole.
- ✓ To keep the IV pole on the same side as the cot/stretchers, you will need to install a Technimount IV Pro Adapter (Refer to Replacement Parts Table).
- ✓ Locating the IV pole on the same side as the Safety Arm System does not interfere with the installation or the operation of the arm.
- ✓ You will need to validate the location of the installation before removing the IV pole hardware.
- ✓ Technimount has two (2) different Safety Arm models. The standard 400 model for Ferno cots or the 500 model for Stryker cots.
- ✓ The installation procedure provided in this user guide is for **Patient Right** installation. The procedure is the same for both right and left sides.
- ✓ You might not have to perform these steps if you do not have an IV pole installed.
- ✓ Please refer to the cot/stretchers manufacturer's manual for more information about installation/re-installation of the IV pole.

# INSTALLATION GUIDE

## PREPARING THE COT/STRETCHER FOR INSTALLATION (CONTINUED)

### REMOVING THE IV POLE OR CHANGING SIDE OF IV POLE (CONTINUED)

1. To access screws that hold the IV pole and the holder, lift the IV pole to its upper position.



2. Remove all four (4) screws.
3. Remove IV Pole and holder.



4. Replace all four (4) screws.

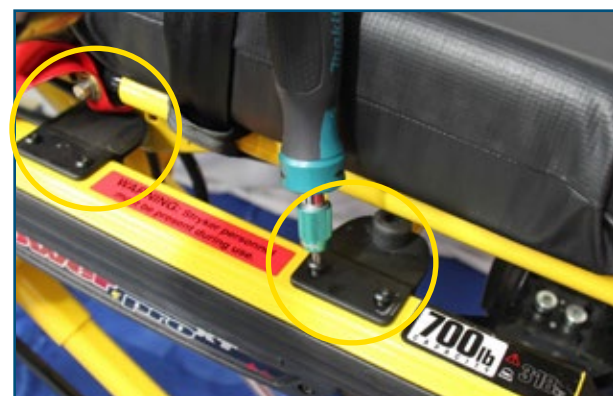

# INSTALLATION GUIDE

---

## PREPARING THE COT/STRETCHER FOR INSTALLATION (CONTINUED)

### REMOVING THE IV POLE OR CHANGING SIDE OF IV POLE (CONTINUED)

5. The IV pole can be installed on the other side of the cot/stretcher, utilizing the same bracket/holder.



6. If the IV Pole is not needed, store for later use.





# INSTALLATION GUIDE

## SAFETY ARM SYSTEM INSTALLATION

### CAUTION

- ✓ It is the responsibility of the Safety Arm System operator to ensure that the system being used on the cot/stretchers meets the installation specifications. Injury may result if a non-compatible cot/stretchers is used.

### NOTE

- ✓ The Safety Arm System Installation instructions are intended for cots/stretchers that you will use with or without a Power-Load system.
- ✓ Adjustment of the clamp block assembly may be required in order to compensate for any variation in the cot/stretchers frame dimension depending on the cot/stretchers manufacturer and model number.

### POSITION ON THE COT/STRETCHER

#### Patient Right and Left Installation

### NOTE

- ✓ When ordering the Safety Arm System, it is important to specify on which side the arm will be installed on, as the System cannot be installed on the opposite side. There is a right or left clamp block designed for each side.
- ✓ The Arm cannot be switched from one side to the other. You need to order a system according to the side that is needed.
- ✓ The location for the installation of the clamp block is the same on patient right or left sides.

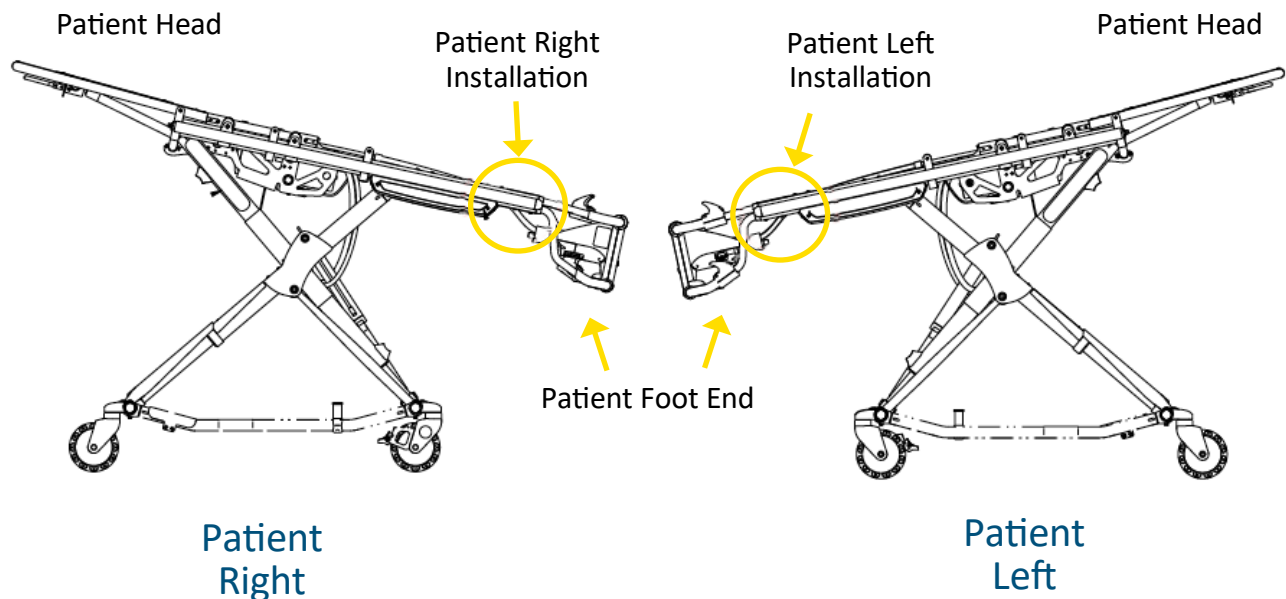

FIGURE 13. MODEL 500 - INSTALLATION POSITION ON PATIENT RIGHT AND LEFT SIDES

[Return To Table of Contents](#)

## SAFETY ARM SYSTEM INSTALLATION (CONTINUED)

### POSITION ON THE COT/STRETCHER (CONTINUED)

#### Patient Right Installation

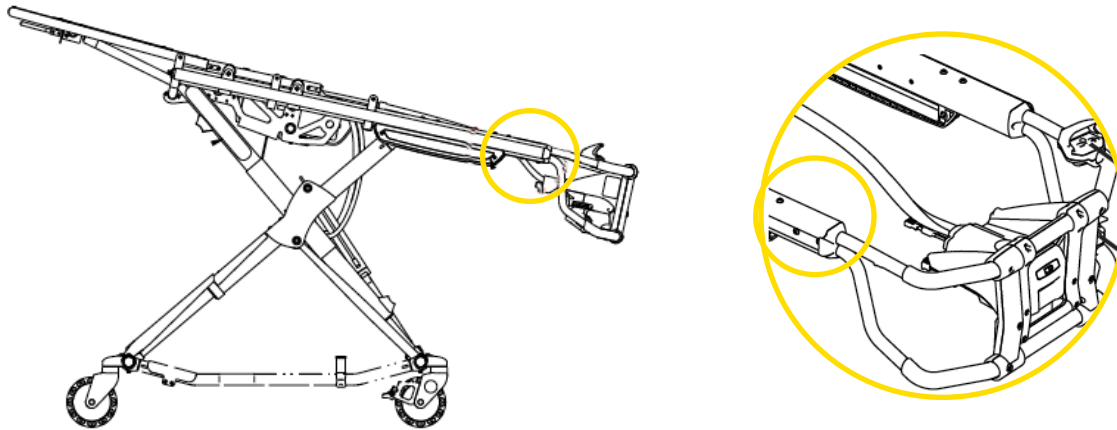

FIGURE 14. POSITION OF THE CLAMP BLOCK ON THE SIDE RAIL FRAME - PATIENT RIGHT

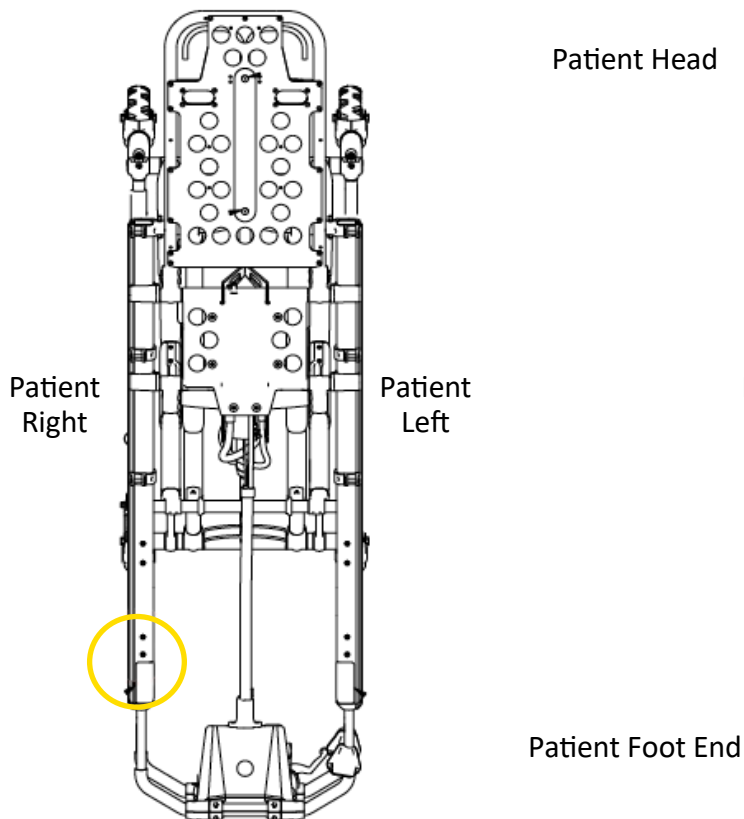

FIGURE 15. POSITION OF SAFETY ARM SYSTEM - PATIENT RIGHT

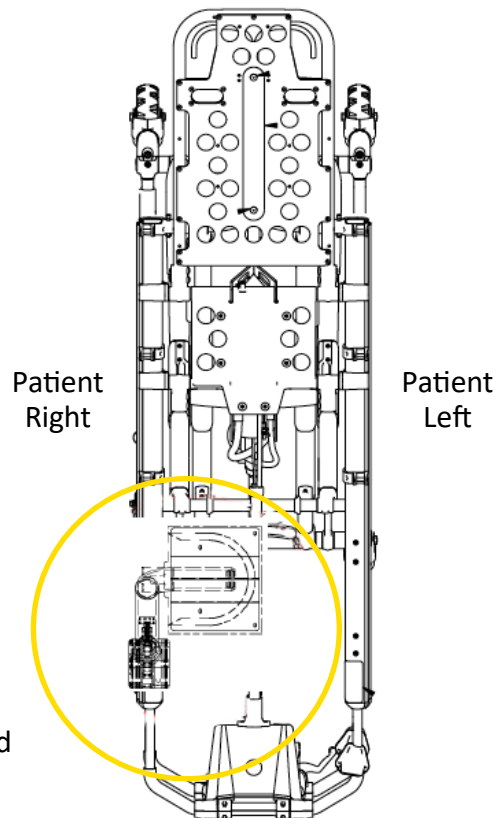

FIGURE 16. PATIENT RIGHT SAFETY ARM SYSTEM INSTALLED AND IN UPPER POSITION (LOCKED)

# INSTALLATION GUIDE

## SAFETY ARM SYSTEM INSTALLATION (CONTINUED)

### INSTALLING THE CLAMP BLOCK (PATIENT RIGHT)

#### NOTE

- ✓ During the installation process, Technimount System recommends the use of Blue Loctite 2400 to avoid premature loosening of screws during normal use. Put a few drops of Blue Loctite on each screw prior to installation.



The Loctite™ Brand shown above is provided as a suggestion only. Technimount System and its subsidiaries are not related to, nor does it commercially endorse this brand.

1. Identify the location on the cot/stretchers where you need to install the clamp block.



2. Locate the two (2) screws that are attached under the front section of the frame.



# INSTALLATION GUIDE

## SAFETY ARM SYSTEM INSTALLATION (CONTINUED)

### INSTALLING THE CLAMP BLOCK (PATIENT RIGHT) (CONTINUED)

3. Unscrew the 2 bolts with 3/16 in Allen key (or Star bite S2-T27) and set aside to be used in next step.
4. Remove the spacer, and store it, as it won't be used in the installation. Clamp Block Replaces this part.
5. Loosen the 2 screws that are on the opposite side of the stretcher to facilitate the installation of the clamp block.



6. Unscrew the four (4) hexagon socket open head screws of the clamp block with the 3/16 in Allen key.



7. Use the part with the fixed red handle to place vertically on the inside of the cot/stretcher frame.



# INSTALLATION GUIDE

## SAFETY ARM SYSTEM INSTALLATION (CONTINUED)

### INSTALLING THE CLAMP BLOCK (PATIENT RIGHT) (CONTINUED)

8. Position the clamp block under the black plate of the frame.



9. Align with the two (2) screw holes.



10. Add a couple of drops of blue Loctite 2400 to the screws before installation.
11. Tighten screws, while alternating screwheads.
12. Tighten the screws located on the opposite side of the stretcher.



[Return To Table of Contents](#)

## SAFETY ARM SYSTEM INSTALLATION (CONTINUED)

### INSTALLING THE CLAMP BLOCK (PATIENT RIGHT) (CONTINUED)

13. Position the other side of the clamp block. A tiny yellow line of the frame should remain visible.
14. Add a couple of drops of blue Loctite 2400 to the screws before installation.



15. Tighten all four (4) hexagon socket pan head screws, while alternating with all four (4) screws.



16. Once the clamp block is properly installed, you are ready to install the Safety Arm into the clamp block.



## SAFETY ARM SYSTEM INSTALLATION (CONTINUED)

### INSTALLING THE SAFETY ARM INTO THE CLAMP BLOCK

1. Pull the fixed safety pin (red round handle) outward and adjust the arm to align the hole of the clamp block with the hole of the triangle at the base of the arm.



2. Push the Lock pin in until the finger ring is flat against the wall of the clamp.



3. The fixed safety pin (red round handle) and side lock pin (finger ring) should be fully inserted and locked when the arm is in the upper position (Locked).

### **WARNING**

Failure to insert the side safety pin properly may result in injury to the patient or operator and/or damage to the cot/stretcher and/or the medical equipment.



# INSTALLATION GUIDE

## SAFETY ARM SYSTEM INSTALLATION (CONTINUED)

### INSTALLING THE STANDARD SURFACE BASE ONTO THE SAFETY ARM SYSTEM UPPER PLATE

1. Ensure that the Safety Arm System is in the upper position (Locked).



2. Identify the desired location of the surface base on the upper plate.

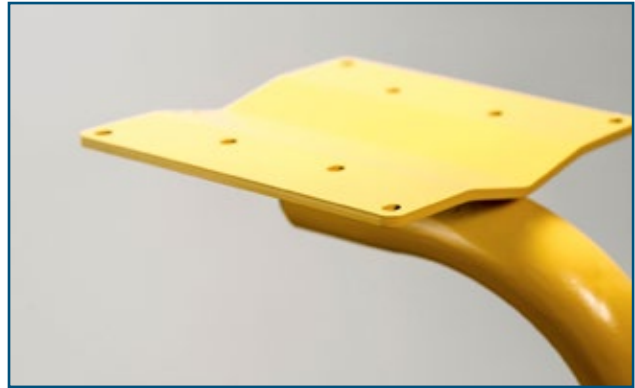

3. Keep in mind the position of the “red” quick release mechanism for easy access to the medical device. The base can be installed in 2 different positions, according to desired configuration and protocol. Can be turned in the other direction, (180°).





## SAFETY ARM SYSTEM INSTALLATION (CONTINUED)

### INSTALLING THE STANDARD SURFACE BASE ONTO THE SAFETY ARM SYSTEM UPPER PLATE (CONTINUED)

#### NOTE:

You will use only four (4) holes on the upper plate.

1. Place the standard base on top of the arm's surface plate and use the hardware provided to secure the base to the plate. (Refer to "Figure 20. Patient Right Safety Arm System Installation of the Standard Surface Base on Upper Plate" on page 33 .
2. The round headed hexagon nuts (2) should be placed on the same side of the arm to cover the longer of the 4 bolts.
3. Use the (2) longer bolts to secure the back of the surface base on the opposite side of the red quick release button.

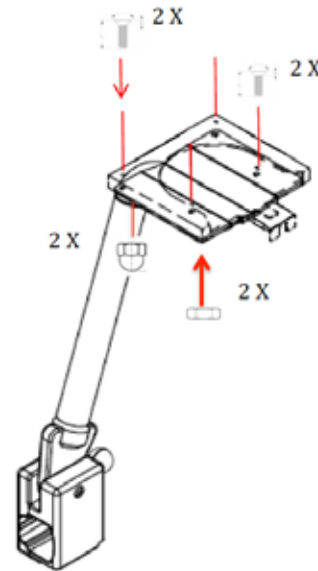

**FIGURE 17. PATIENT RIGHT SAFETY ARM SYSTEM INSTALLATION OF THE STANDARD SURFACE BASE ON UPPER PLATE**

4. Align the two (2) screws 10-32 in x 1-3/4 in with the two (2) pre-drilled holes in the back of the upper plate and the surface base. Use Loctite™ on the four (4) bolts to avoid potential loosening of the screws, due to vibration.
5. Repeat the same step with the other two (2) screws 10-32 in x 1-1/4 in at the front or the middle of the base, and tighten them in place with the Philips screwdriver.

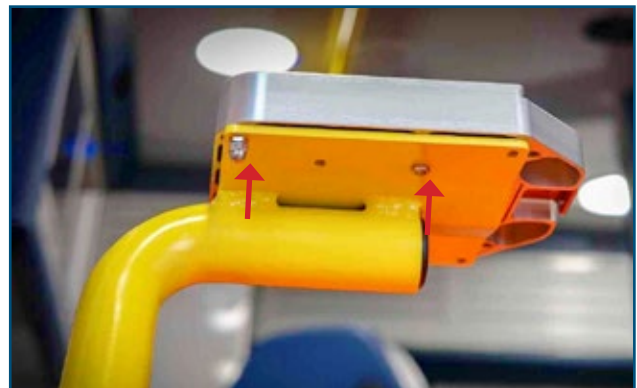

6. Tighten all four (4) screws of the surface base at the front, and at the back with the Philips screwdriver and the mechanical wrench SAE 3/8 in.



[Return To Table of Contents](#)

# OPERATION CAUTION AND WARNING

## SAFETY ARM SYSTEM INSTALLATION (CONTINUED)

### INSTALLING THE STANDARD SURFACE BASE ONTO THE SAFETY ARM SYSTEM UPPER PLATE (CONTINUED)

#### CAUTION

- ✓ Before operating the arm, clear any obstacles that may interfere and cause injury to the operator, patient or that may damage the medical equipment.
- ✓ Always keep a safe distance from the foot end of the cot/stretcher, clear of any obstacles while operating the arm. Maintain a minimum distance of at least 24 inches (2 feet) while operating.

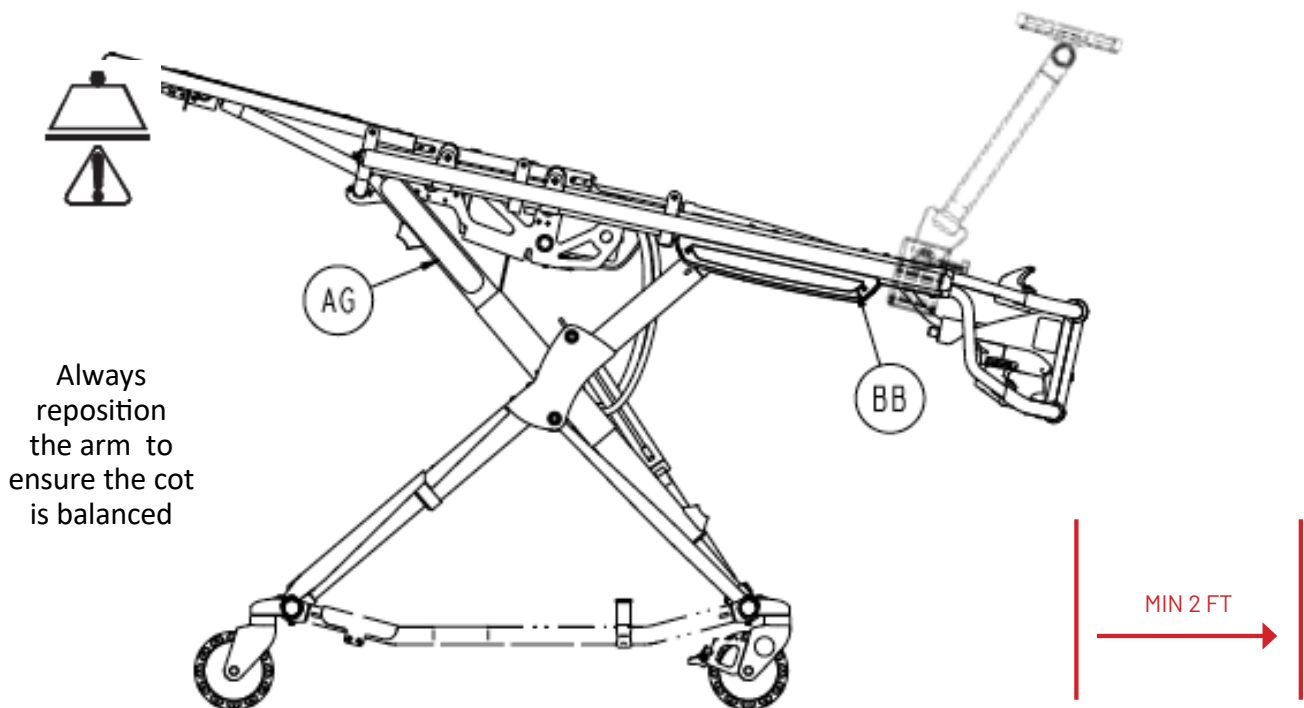

**FIGURE 18. PATIENT COT/STRETCHER WITH SAFETY ARM SYSTEM INSTALLED**

#### WARNING

- ✓ Improper usage of the Safety Arm System can cause injury to the patient or operator. Operate the product only as described in this user guide.
- ✓ Do not allow untrained staff to assist in the operation of the arm. Untrained technicians/staff can cause injury to the patient or themselves.
- ✓ Always hold the arm securely when you manipulate it not to drop the safety arm. Dropping the arm could cause injury to the operator or patient.
- ✓ Always pull and hold the locking safety pin (red handle) until it reaches the final position (up (locked) or down (un-locked)) so the arm doesn't fall during transport. Failing to do so can cause injury to the operator or patient.

[Return To Table of Contents](#)

## GENERAL OPERATING GUIDELINES

- ✓ Use the Safety Arm System only as described in this User Guide.
- ✓ Read all the labels and instructions on the product before using the Safety Arm System.
- ✓ Always inspect the clamp block and arm area for cracks and/or damage before every use.
- ✓ Loading or unloading the Safety Arm System requires a minimum of one (1) trained operator, however, two (2) trained operators are recommended when possible.
- ✓ Do not adjust, or change the arm position while moving with the cot/stretchers.
- ✓ Stay with the patient and control the arm at all times.
- ✓ The arm can be placed into two (2) positions: Locked (Upper position) & Unlocked (Lower position).
- ✓ It is recommended that operators use the system in the upper or locked position while the cot/stretchers is mobile or while the vehicle is moving.
- ✓ Always verify the fixed lock pin is secure prior and during use of the Safety Arm System.
- ✓ Always verify if the side safety pin is firmly pushed and locked into position inside the clamp block during use.



## RECOMMENDED LIFTING TECHNIQUES

When lifting the arm, there are six basic guidelines to help you avoid injury:

1. Keep your hands clear from pinch points
2. Keep your back straight
3. Coordinate your movements with your partner on positioning the arm
4. Avoid twisting
5. Always operate the arm as described in this user guide
6. Always secure the movement of the equipment by holding the arm firmly



## GENERAL OPERATING GUIDELINES (CONTINUED)

### WARNING

- ✓ Never let a patient grab, manipulate or hold the surface base or the arm on the cot/stretcher or it may cause injury to the operator or patient. Secure the arm as recommended while the patient is on the cot/stretcher.
- ✓ Always transport the patient while the arm is in the upper or locked position.
- ✓ Lower to the unlocked position when loading and unloading the patient.
- ✓ The upper or locked position maintains the balance of the cot/stretcher and reduces the potential of a cot/stretcher tipping.
- ✓ It is extremely important to raise the safety arm up along the same axis, to its maximum position, even with the weight of the medical device, in order to not damage the tip of the triangle head. Improper positioning of the arm can cause premature damage or cause improper functioning of the system.

### RECOMMENDED HANDLING POSITIONS

- ✓ Hold the arm's tubular frame at the center or close to the top near the base.
- ✓ Avoid placing your hands too close to the clamp block base due to pinch points that may cause injury to the operator.
- ✓ To raise the arm in locked position, release the fixed lock pin and pull the arm up.

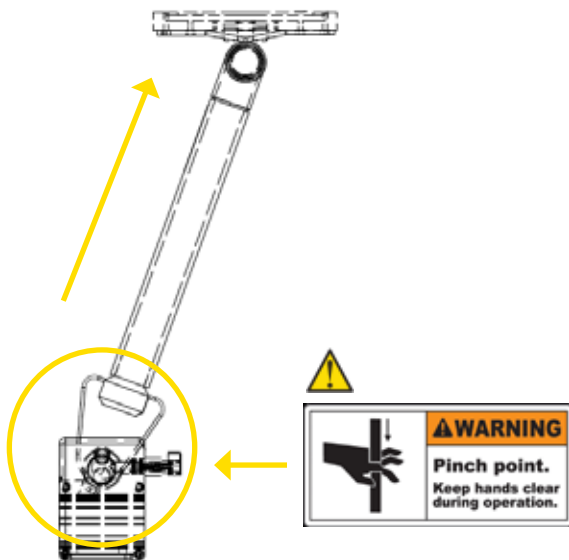

**FIGURE 19. SAFETY ARM SYSTEM IN UPPER POSITION (LOCKED)**

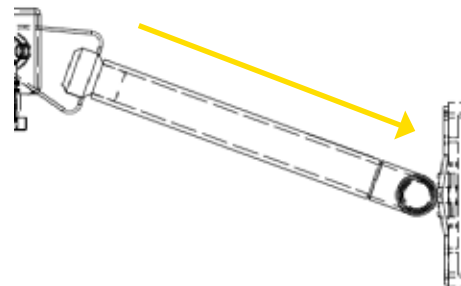

**FIGURE 20. SAFETY ARM SYSTEM IN LOWER POSITION (LOCKED)**

### WARNING

- ✓ It is extremely important to raise the safety arm up along the same axis, to its maximum position, even with the weight of the medical device, not to damage the tip of the triangle head. Improper positioning of the arm can cause premature damage or cause improper functioning of the Safety Arm System.

## RECOMMENDED HANDLING POSITIONS (CONTINUED)

### NOTE

- ✓ The tip of the triangle head is used to stop the arm from movement (i.e. in case of a rear-end collision) and to secure the arm at a fixed point and engage the fixed locking mechanism.

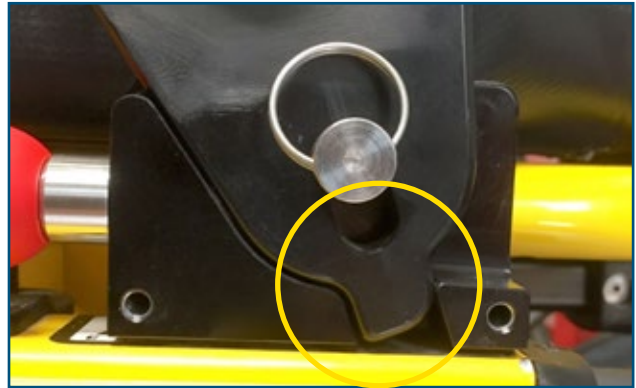

FIGURE 22. MAXIMUM UPPER POSITION

## OPERATING THE SAFETY ARM SYSTEM

---

### WARNING

- ✓ Two (2) trained operators should be present when repositioning the arm while the cot/stretcher is occupied.
- ✓ Operators must be able to safely lift the total weight of the system including the arm, the medical device and any other item related to the system.
- ✓ Ensure proper hand placement on the tubular pole or surface plate. Hands should be clear of the black clamp block and arm pivot points while loading and unloading the medical equipment or whenever changing height of the arm with two or more operators.

## OPERATING THE SAFETY ARM SYSTEM (CONTINUED)

### LOWERING THE SAFETY ARM

1. Pull and hold the fixed safety pin (red round handle) in order to disengage the triangle head from the clamp block base.

#### WARNING

 Do not put hands near the surface of the triangle head or near the pin inside the opening, during manipulation. Potential pinch point.



2. While keeping the safety pin extended to its fullest extent, lift the arm upwards in the same axis as the arm to reduce friction or resistance when lifting.

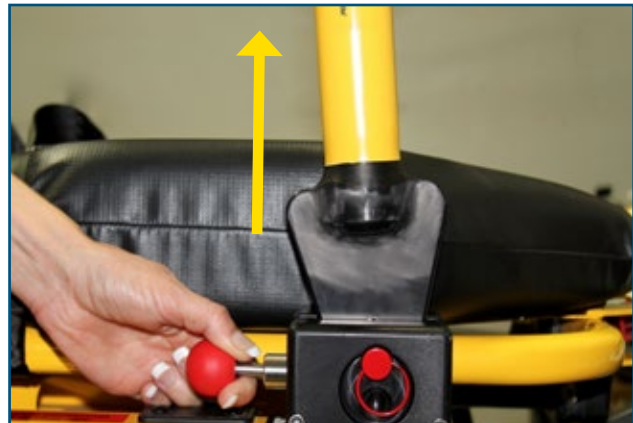

3. Lower the arm until it is in the horizontal position, parallel with the cot/stretchers frame.
4. Release the fixed safety pin.



#### WARNING

- ✓ Always remove or check if the device is correctly secured into the surface base, if lowering the unit.
- ✓ Always hold the arm securely when you manipulate it.
- ✓ Always pull and hold the safety pin (red handle) until it reaches the final upper position (locked) or down (unlocked). Failure to pull the fixed safety pin (red handle) when repositioning the arm may cause damage to the Arm or locking mechanism.

[Return To Table of Contents](#)

## OPERATING THE SAFETY ARM SYSTEM (CONTINUED)

### RAISING THE SAFETY ARM

1. Pull and hold the fixed safety pin (red round handle) until it reaches the final position.



2. While holding the safety pin, pull the safety arm up.



3. Bring the safety arm all the way up into vertical position and make sure the triangle head is correctly seated into the clamp block.
4. Release the safety pin to lock the Safety Arm in its vertical position for transport.



### WARNING

- ✓ Always use the system with the locking pin (pin with finger ring) is in the system.
- ✓ Always hold the arm securely when you manipulate it.
- ✓ Always pull and hold the safety pin (red handle) until it reaches the final upper position (locked) or down (unlocked). Failure to pull the safety pin (red handle) when repositioning the arm may cause damage to the Arm or locking mechanism.

[Return To Table of Contents](#)

## OPERATING THE SAFETY ARM SYSTEM (CONTINUED)

### REMOVING THE SAFETY ARM

1. Put the Safety Arm in vertical position.
2. Remove the medical device from the Standard Surface Base on the Safety Arm System.

#### WARNING

Ensure that the medical device has been removed from the standard surface base prior to removing the Safety Arm from the clamp block. Failure to do so, can cause injury to the patient or operator and damage to the equipment and medical device.



3. Remove the fixed lock pin by pulling outwards.



4. Pull and hold the Safety Pin (red round handle).





## OPERATING THE SAFETY ARM SYSTEM (CONTINUED)

### REMOVING THE SAFETY ARM (CONTINUED)

5. While Securely holding the arm, pull upward in order to disengage the triangle head from the clamp block.



6. Once the Safety Arm is removed, put the lock pin back into the clamp block.



# SAFETY ARM SYSTEM OPTIONS

## STRYKER POWERPRO OPTIONS

Some exceptions may apply for the PowerPro Stretcher. Please confirm with Customer Service at [customerservice@technimount.com](mailto:customerservice@technimount.com) prior to placing your order.

<u>DESCRIPTION</u>	<u>OPTION PART NUMBER</u>
Tubular Arm with Triangular Base – Patient Left Installation Yellow-Powder-Coated Finish	400-20-UN-LFS
Angled Arm with Triangular Base – Patient Right Installation Yellow-Powder-Coated Finish	400-20-UN-ANG
Clamp Block – Stryker Cot/Stretcher - Patient Left Installation	500-10-PFXT-LFS
IV Pro Adapter – IV Pole Support – Patient Left Installation - Without Knee Gatch	511-00-UN-LFS - WHKG
IV Pro Adapter – IV Pole Support – Patient Left Installation - With Knee Gatch	511-00-UN-LFS - KG
IV Pro Adapter – IV Pole Support – Patient Right Installation - Without Knee Gatch	511-00-UN-RHS - WHKG
IV Pro Adapter – IV Pole Support – Patient Right Installation –With Knee Gatch	511-00-UN-RHS - KG

## STRYKER MX-PRO OPTIONS

<u>DESCRIPTION</u>	<u>OPTION PART NUMBER</u>
Clamp block for the Stryker MX-PRO Cot/Stretcher – Patient Right Installation	530-10-MXPR
Clamp block for the Stryker MX-PRO Cot/Stretcher – Patient Left Installation	530-10-MXPR-LFS
IV Pro Adapter for the Stryker MX-PRO Cot/Stretcher – Patient Right Installation	511-00-MXP-RHS
IV Pro Adapter for the Stryker/ MX-PRO Cot/Stretcher – Patient Left Installation	511-00-MXP-LFS

### WARNING

Do not modify the arm or any components of the system. Modifying the product can cause unpredictable operation resulting in injury to the patient or operator.

## CLEANING THE SAFETY ARM SYSTEM

### CLEANING PROCESS

The Safety Arm System can be cleaned by using a pressure washer. The unit may show some signs of oxidation or discoloration from continuous washing, however, degradation of the cot/stretcher's performance or functionality will not be affected due to power washing if cleaning instructions are properly followed.

The material used to manufacture the Safety Arm System is high-grade aluminum, it is very durable and resistant to corrosion, however high levels of sodium or a high concentration of sodium or acid may prematurely corrode the product. Always rinse with soft soap and water if exposed.

- ✓ Use of a power washer can accelerate removal of contaminants collected during the use of the product.
- ✓ Rinse with clean water.
- ✓ Towel dry all casters and interface points, inside the triangle head and clamp block.
- ✓ Allow all other components to air dry.
- ✓ Avoid over saturation and ensure that the product does not stay wet longer than the cleaner manufacturer's guidelines for proper disinfecting.



### WARNING

- ✓ When cleaning, always use appropriate personal protection equipment (PPE) based on established protocols (e.g., gloves, eyewear, etc.).



### CAUTION

- ✓ Do not steam clean or use ultrasonic cleaners on the system or any of its components.
- ✓ Do not immerse the metal parts/components in water.
- ✓ Maximum water temperature should not exceed 180°F/82°C
- ✓ Maximum water pressure should not exceed 1500 psi/103.5 BAR . If a pressure washer is being used to clean the unit, the pressure nozzle must be kept a minimum of 24 inches (61 cm) from the unit.

### CLEANING SOLUTIONS

Phenolic type or quaternary type disinfectants can be used (excluding Virex® TB). Iodophor type disinfectants, Peracetic Acid, Chlorine, and especially Peroxide Oxygen are not recommended for use because staining and corrosion may result.

Suggested cleaners for the Safety Arm System surfaces and clamp box:

- ✓ Quaternary Cleaners (active ingredient - ammonium chloride)
- ✓ Phenolic Cleaners (active ingredient - o-phenyl phenol)
- ✓ Chlorinated Bleach Solution (3.25% - less than 1-part bleach to 100 parts water)

## CLEANING THE SAFETY ARM SYSTEM (CONTINUED)

### CLEANING SOLUTIONS CONTINUED

---

#### WARNING

- ✓ Some cleaning products are corrosive in nature and may cause damage to the product if used improperly.
- ✓ If the products described above are used to clean the equipment, the Safety Arm System must be rinsed with clean water and thoroughly dried following cleaning. Failure to properly rinse and dry the Safety Arm will leave a corrosive residue on the surface of the product, possibly causing premature corrosion of critical components.

### REMOVAL OF IODINE COMPOUNDS

Use a solution of 1/4 Tablespoon of Sodium Thiosulfate in 1 pint / .5 litre of warm water to clean the stained area. Clean as soon as possible after staining occurs. If stains are not immediately removed, allow solution to soak or stand on the surface. Thoroughly rinse surfaces with clean water and allow to air dry before returning unit to service.

---

#### WARNING

- ✓ Failure to properly clean contaminated parts or components will increase the risk of exposure to blood borne pathogens and may cause injury to the patient or the operator.

## PREVENTIVE MAINTENANCE

A preventive and regular maintenance program should be established for all Technimount equipment. Preventive maintenance may be required more frequently based on the usage level of the product. The Safety Arm System requires regular preventive maintenance. Establish and follow a preventive maintenance schedule and keep records of preventive maintenance activities (see maintenance form).

---

#### CAUTION

- ✓ Close attention should be given to safety features including, but not limited to the clamp block, tubular arm, surface plate, and standard surface base mount.
- ✓ Improper maintenance can cause injury or damage to the product. Maintain the product as described in this user guide.

### LUBRICATION

The Safety Arm System has been designed to operate without the need for lubrication. Due to an anodization of the metallic parts, using a silicone-base lubricant can be used but it is not necessary. If you're not sure about the product to use, please contact technical support or customer service.

---

#### CAUTION

- ✓ Failure to use authorized parts, lubricants, etc. could cause damage to the cot/stretcher and will void the warranty of the product.

# MAINTENANCE GUIDE

## INSPECTION PROCESS AND SCHEDULE

### PREVENTIVE MAINTENANCE PROGRAM

The following inspection routine and schedule is intended as a general guide for preventive maintenance of the Safety Arm System. Factors such as weather, environment, geographical location, and individual usage will necessitate different maintenance. If you are unsure as to how to perform these maintenance inspections or at what interval to perform these inspections, please contact your Technical Support Team at [techsupport@technimount.com](mailto:techsupport@technimount.com). Check each routine and replace damaged or worn out parts if necessary.

Follow table below in accordance to the timetable, whichever comes first.

ITEM	ROUTINE	<u>1 M</u> <u>OR</u> <u>2 H</u>	<u>3 M</u> <u>OR</u> <u>6 H</u>	<u>6 M</u> <u>OR</u> <u>12 H</u>	<u>12 M</u> <u>OR</u> <u>24 H</u>
Clamp Block	<ul style="list-style-type: none"> <li>✓ Inspect the 4 hexagon screws of the clamp block                             <ul style="list-style-type: none"> <li>▪ If loose, or unscrewed, tighten screw</li> <li>▪ If broken, the screw must be replaced</li> </ul> </li> <li>✓ Inspect and tighten the 2 bolts under the clamp block that hold the system on the cot/stretchers frame</li> <li>✓ Check fixed safety lock                             <ul style="list-style-type: none"> <li>▪ Ensure it is working properly and there are no particles, obstacles, or debris</li> </ul> </li> <li>✓ Check side safety lock pin                             <ul style="list-style-type: none"> <li>▪ Must be locked properly</li> </ul> </li> <li>✓ Verify if the frame of the cot/stretchers is not cracked or broken around the area of the clamp block</li> </ul>	X			
Arm - Tubular Pole	<ul style="list-style-type: none"> <li>✓ Verify all welds are intact, not cracked or broken</li> <li>✓ Verify not that the Arm is not bent, broken, or has damaged components</li> <li>✓ Verify that the retaining post is secure</li> <li>✓ Verify that there is no excessive damage to Arm</li> <li>✓ Verify the Arm operates properly</li> </ul>		X		
Surface Plate	<ul style="list-style-type: none"> <li>✓ Inspect the 4 bolts and nuts to secure the surface base onto the surface plate</li> </ul>	X			

[Return To Table of Contents](#)





## REPLACEMENT PARTS

The parts and accessories listed are all currently available for purchase. Some of the parts identified on the assembly drawing parts in this user guide may not be individually available for purchase. Please call Technimount Customer Service or Technical Support : +1.581-998-9820 or at [customerservice@technimount.com](mailto:customerservice@technimount.com) or [techsupport@technimount.com](mailto:techsupport@technimount.com) for availability and pricing.

<u>DESCRIPTION</u>	<u>PART NUMBER</u>
Clamp Block – for the Stryker Cot/Stretcher - Patient Right Installation	500-10-PFXT
Tubular Arm with Triangular Base – Patient Right Installation with Yellow-Powder-Coated Finish	400-20-UN
Stainless Steel Side Lock Pin - Without Color	910-00-UN
Stainless Steel Side Lock Pin - Red-Anodized Finish	910-00-PTR
Fixed Safety Pin with Red Handle (Kit with 3 parts)	920-00-UN
Label – Brand Name	940-00-UN
Label – Instructions in English	930-00-EN
Label – Instructions in French	930-00-FR



## WARRANTY POLICY

Original purchasers will obtain a one-year limited warranty on all parts including the arm and the clamp block. Technimount's obligation under this one-year (1) warranty is limited to supplying replacement parts and labor for any component or option of this system that is found to be defective, at Technimount's sole discretion.

Upon Technimount's request, purchaser shall return to Technimount's shipping warehouse any product or part (freight prepaid by Technimount) for which an original purchaser makes a warranty claim.

Any improper use or alteration or repair by unauthorized service providers shall void this warranty.

This statement constitutes Technimount's entire warranty with respect to the aforementioned equipment.

Technimount System makes no other warranty or representation either expressed or implied, except as set forth herein. There is no warranty of merchantability and there are no warranties of fitness for any particular purpose. In no event shall Technimount be liable hereunder for incidental or consequential damages arising from or in any manner related to sales or use of any such equipment.

Technimount System guarantees to the original Purchaser of the Hardware with which this Limited Warranty is included, that the Hardware will be free from Defects in workmanship and material under normal use for a period of one (1) year from the date that the Hardware was first purchased, which is defined as the Warranty Period. During the Warranty Period, the Hardware will be repaired or replaced according to the Limited Warranty without charge to the purchaser for either parts or labor. The parts may be repaired or replaced with either new or refurbished parts. The product may be replaced for a new or refurbished product. For this Limited Warranty, refurbished means parts and products which have been returned to factory specifications. If the Hardware is repaired or replaced within the Warranty Period, the greater of the remaining warranty period will apply or three (3) months from the date of repair/replacement. If the Hardware is repaired or replaced after the Warranty Period has expired, the Warranty Period for the repair or replacement will expire three (3) months after the date of repair or replacement.

### LIMITED RESPONSIBILITY AND WARRANTY

Technimount System shall not be responsible for damage to the part or products resulting from improper installation or use, abuse, neglect, accident, servicing or any modification to any part of a Technimount product by anyone other than Technimount System or an organization certified by Technimount. Please always refer to the Stretcher Safety Arm 500 User Guide for the proper installation and use of the product.

The Limited Warranty does not apply to normal wear that should result from normal use. It does not apply when the hardware or any component is opened, disassembled, or repaired by someone not authorized by Technimount and does not cover repair or replacement of any Hardware or part thereof damaged by: neglect, misuse, moisture, liquids, exposure to heat, accidents, abuse, and non-compliance with the instructions for installation and use supplied with the Hardware. The Limited Warranty does not cover physical damage to the surface of the Hardware.

The hardware or product defined in this user guide as a mounting or bracket system for clipping and attaching medical equipment are specifically designed to fill this requirement. Any other use will void the warranty and Technimount will not be held liable for, or on any form of a claim if the product is modified or adapted for use.

## WARRANTY OPTIONS

### THREE WARRANTY OPTIONS FOR TECHNIMOUNT PRODUCTS

1. One-year (1) additional warranty after the original warranty has expired for parts and labor has terminated. Technimount guarantees to the original purchaser that its products should be free from manufacturing nonconformities that affect product performance and customer satisfaction for a period of one (1) year following the end date of the original warranty. Technimount's obligation under this warranty is limited to supplying replacement parts and labor for, or replacing for any product or option, that is found to be defective, at Technimount's sole discretion.
2. Two-year (2) additional warranty after the original warranty for parts and labor has terminated. Technimount guarantees to the original purchaser that its products should be free from manufacturing -nonconformities that affect product performance and customer satisfaction for a period of two (2) years following the end date of the original warranty. Technimount's obligation under this warranty is limited to supplying replacement parts and labor for any component or option of this system that is, found to be defective at Technimount's sole discretion.
3. Three- year (3) additional warranty after the original warranty for parts and labor has terminated. Technimount guarantees to the original purchaser that its products should be free from manufacturing nonconformities that affect product performance and customer satisfaction for a period of three (3) years following the end date of the original warranty. Technimount's obligation under this warranty is limited to supplying replacement parts and labor for any component or option of this system that is found to be defective, at Technimount's sole discretion.

## INTERNATIONAL WARRANTY CLAUSE

This warranty reflects Canadian domestic policy. Warranty outside Canada may vary by country. Please contact your local Technimount representative for additional information.

# RETURN POLICY

---

## RETURN OF MERCHANDISE

The Safety Arm System parts and/or components may be returned up to 60 days of receiving the product(s) if they meet the following guidelines:

### PRIOR TO 30 DAYS

- ✓ 30-day money back guarantee in effect
- ✓ Technimount is responsible for all charges
- ✓ Returns will not be approved on modified item
- ✓ Charges may apply if damaged or missing items

### PRIOR TO 45 DAYS

- ✓ Product must be unused, undamaged and in the original packaging
- ✓ Customer is responsible for a 20% restocking fee
- ✓ Reasons of returning the product must be provided in writing
- ✓ Returns will not be approved on modified or damaged item
- ✓ Charges may apply if damaged or missing items

### PRIOR TO 60 DAYS

- ✓ Product must be unused, undamaged and in the original packaging
- ✓ Customer is responsible for a 30% restocking fee
- ✓ Reasons for returning the product must be provided in writing
- ✓ Returns will not be approved on modified or damaged item
- ✓ Charges may apply if damaged or missing items

### RETURN MERCHANDISE AUTHORIZATION

Technimount's customer service department is responsible for approving any merchandise return and will provide an RMA (Return Merchandise Authorization) number to be printed on any returned merchandise. Technimount reserves the right to charge shipping and restocking fees on returned items. Customized, modified, or discontinued items not subject to return.

### DAMAGED MERCHANDISE

ICC Regulations require that claims for damaged merchandise must be made with the carrier within fifteen (15) days of receiving merchandise. Do not accept damaged shipments unless such damage is noted on the delivery receipt at the time of receipt. Upon prompt notification, Technimount will file a freight claim with the appropriate carrier for damages incurred. Claim will be limited in amount to the actual replacement cost. In the event that this information is not received by Technimount within the fifteen (15) day period following the delivery of the merchandise, or the damage was not noted on the delivery receipt at the time of receipt, the customer will be responsible for payment of the original invoice in full.

### NOTE

Claims for any short shipment must be made within thirty (30) days of invoice.



# SAFETY AND FLEXIBILITY WHERE IT MATTERS MOST

TECHNIMOUNT SYSTEM - BRAND OF TECHNOLOGIES CGC

Corporate Headquarters

3770 Jean Marchand Street, Suite 100

Quebec (QC) G2C 1Y6

Canada

T + 1 581.998.9820

F + 1 855.339.6351

[technimount.com](http://technimount.com)

[info@technimount.com](mailto:info@technimount.com)

© Copyright 2020 Technimount System All Rights Reserved

Printed in Canada



**TECHNIMOUNT**  
SYSTEM™

SAS UG 202002-R01