



TECHNIMOUNT
SYSTEM™



TECHNI-SHIELD DEFENDER™

TECHNICAL BULLETIN

TECHNI-SHIELD DEFENDER™

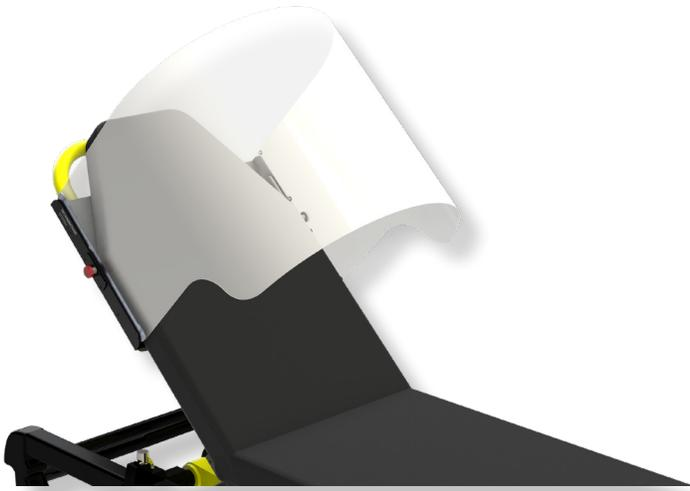

Product Description

The Techni-Shield Defender™ is a protective screen for stretchers developed to help reduce the spread of contaminated droplets in the air.

It is a removable, transparent screen that acts as an additional barrier between the patient and emergency staff to reduce the risk of exposure to patients potentially contaminated with infectious respiratory diseases.

Introduction

The Techni-Shield Defender™ is a transparent protective barrier, adjustable in two directions (up or down) in order to protect paramedics from patients potentially suffering from a respiratory disease infection.

This protective screen allows additional protection to be added for paramedics, in order to reduce the risk of exposure to a potentially contaminated patient. It does not replace Personal Protection Equipment (PPE), but adds another barrier of protection. It is designed to reduce the spread of contaminated drizzle in the air.

This screen is made from chemical-resistant material with a polyester, biological grade film, which is easy-to-clean. The system allows it to be installed or removed in less than ten seconds, without any specific tools. It is adaptable to most stretchers in North America.

It is flexible and light, built with an aluminium-anodized structure resistant to corrosion, or any biological cleaning products. Its frame size adapts to the shape of the patient on the stretcher, making it suitable for the ambulance environment or in confined spaces.

TECHNI-SHIELD DEFENDER™

Its design enables ventilators or other medical devices to be installed around the patient. As the screen is not closed, less oxygen consumption is required in comparison to a restricted space. When not in use, it can be stowed underneath of the mattress of the stretcher, ensuring it is available when needed.

Scientific based on the development

The Techni-Shield Defender™ is an additional form of PPE.

Looking at the speed of contagion with the virus (COVID-19), we found that masks and other protection equipment are wasteful as they are disposable, resulting in negative environmental impacts.

We developed the design in relation to clinical models, taking into consideration the spray droplet zone when a patient has a respiratory infection.

The first figure shows a typical model of air contamination when a patient exhales. You can observe the repartition of the aerosols, and the direction also.

Based upon clinical information, we designed the screen as a response to the spray zone in relation to patient morphologies, and the fact that masks and facial protection reduce risk, as supported by a recent study¹.

The Techni-Shield Defender™ was designed based upon the standard patient size. When a patient is laying down on the mattress on the cot, you can see in the second figure the potential position of their head in relation to their potential exhale angles.

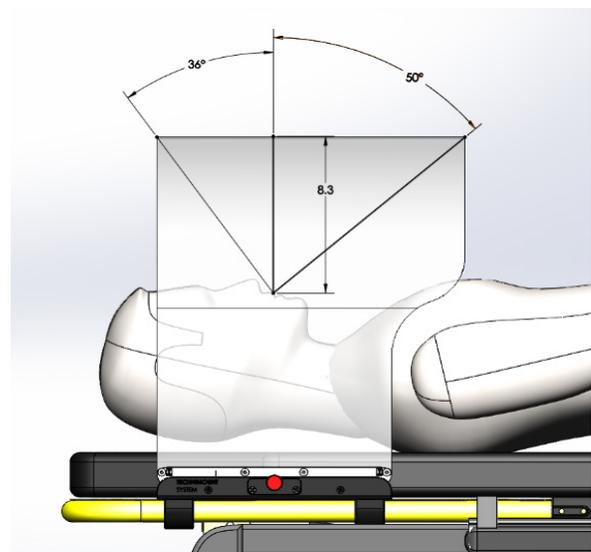
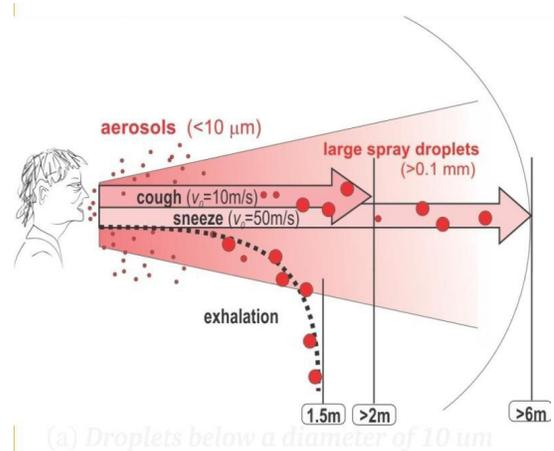

PROTECTING EMS RESPONDERS

Even if the bracket is in the upright position, the position will not change a great deal. It is possible to adapt the position by simply releasing the red knob and sliding the screen into its desired place.

This additional protection for paramedics or clinicians is aligned with the scale of protection recommended by the CDC (Center of Disease and Control and Prevention) part the NIOSH (National Institute for Occupational Safety and Health) in the United States of America (USA).

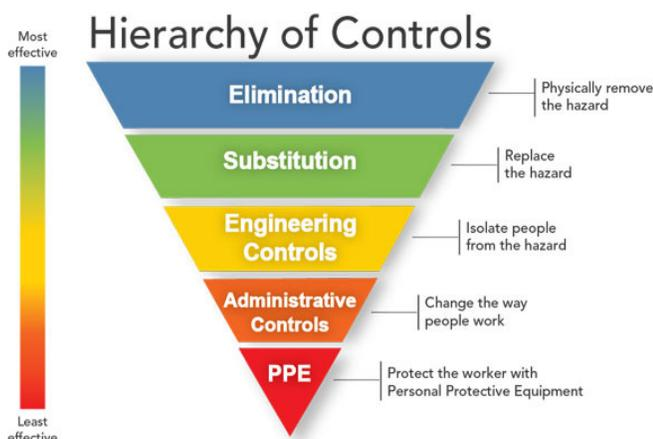

The organization established a hierarchy of control related to effective and control solutions. The idea behind this hierarchy is that the control methods at the top of the graphic are potentially more effective and protective than those at the bottom.

Following this hierarchy normally leads to the implementation of inherently safer systems, where the risk of illness or injury has been substantially reduced².

The Techni-Shield Defender™ is categorized between “Administrative Controls”; as it is not exactly related to PPE, however, it isolates the patient by adding an additional protective measure; and “Engineering Controls”; as the patient or hazard is not totally isolated, however, additional protection is added which increases the control of the infection. If we refer to the “[Engineering Controls](#)” level of the hierarchy, we support and are aligned with this definition, by “...placing a barrier between the worker and the hazard. Examples include local exhaust ventilation to capture and remove airborne emissions or machine guards to shield the worker”.

The development of this product is not just for the actual pandemic situation but will support other related protocols in EMS and Health networks. The AGMP (Aerosol Generating Medical Protocol) is a foundational procedure in EMS, in reference to patients with known or suspected airborne transmissible diseases such as tuberculosis, varicella zoster virus and the measles, along with other medical procedures.

TECHNI-SHIELD DEFENDER™

Conclusion

The Techni-Shield Defender™ provides additional protection in relation to the Hierarchy of Control, at the Engineering Control level, in order to support and slowdown the progression of the infection.

It is a reusable screen which helps reduce operating costs, does not create unnecessary environmental waste and is quick and easy to install. It is a highly flexible product, suitable for the operational needs of EMS during patient transport.

We at Technimount System strongly believe that the Techni-Shield Defender™ is the next procedural step building upon AGMP, helping to reduce risks.

Graphical Representation of the Techni-Shield Defender™

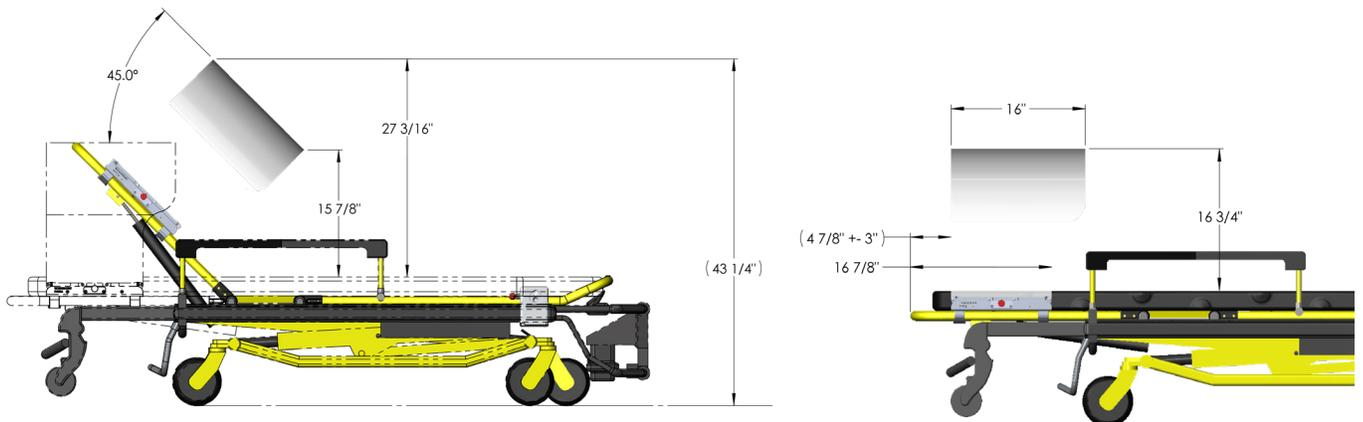

Additional Techni-Shield Defender™ Product Information

Web Page - [Techni-Shield Defender](#)

Technical Information - [Techni-Shield Defender™ Datasheet](#)

¹ Reference: Nature Medicine – Brief Communication – Respiratory virus shedding in exhaled breath and efficacy of face masks; Published April, 3rd, 2020

² Reference: Website <https://www.cdc.gov/niosh/topics/hierarchy/default.html>; CDC (Center of Disease and Control and Prevention) part of NIOSH in USA.

* The information source, company names or other organizations that may have been identified thru our bulletin have no direct relationship or commercial agreement with Technimount System or any other subsidiaries; and the product name and describes is the ownership of HTMC Medical Inc. in partnership with Technimount System.



SAFETY AND FLEXIBILITY WHERE IT MATTERS MOST

TECHNIMOUNT SYSTEM - BRAND OF TECHNOLOGIES CGC

Corporate Headquarters

3770 Jean Marchand Street, Suite 100

Quebec (QC) G2C 1Y6

Canada

T + 1 581.998.9820

F + 1 855.339.6351

technimount.com

info@technimount.com

© 2020 Technimount System - All Rights Reserved

technimount.com

