



TECHNIMOUNT
EMS™

BRACKET PRO SERIE® 60-SD

USER GUIDE



COPYRIGHT

Copyright 2021 Technimount E.M.S. Holding Inc. (Technimount), an affiliated company of Technologies CGC Inc. All Rights Reserved. No part of this publication may be reproduced, transmitted, transcribed, stored in a retrieval system, or translated into any language in any form or by any means without the written permission of Technimount or its affiliate companies.

Trademark Attributions:

Bracket Pro Serie®, Technimount EMS™ are registered trademarks of Technologies CGC Inc.

Hamilton T1® is a registered trademark of Hamilton Medical.

Technimount does not have any commercial relationship with Hamilton Medical. Hamilton Medical does not promote or sell Technimount products.

In order to ensure continuous improvements to our products and services, we invite you to communicate your comments to our Customer Service Department at customerservice@technimount.com.

CONTACT INFORMATION

OFFICE ADDRESS

TECHNIMOUNT E.M.S. HOLDING INC.
3770 Jean Marchand Street, Suite 100-C
Quebec (QC) G2C 1Y6
Canada

info@technimount.com

www.technimount.com

T + 1 888.639.2758

F + 1 855.339.6351

NOTE:

For any issues with your Technimount product, its components, or for any technical questions during the installation or maintenance, please send an email to techsupport@technimount.com.

Please have the serial number of your Technimount product available (as shown in the figure below) when calling Technimount Technical Support. Include the serial number in all written communications.

SERIAL NUMBER LOCATION

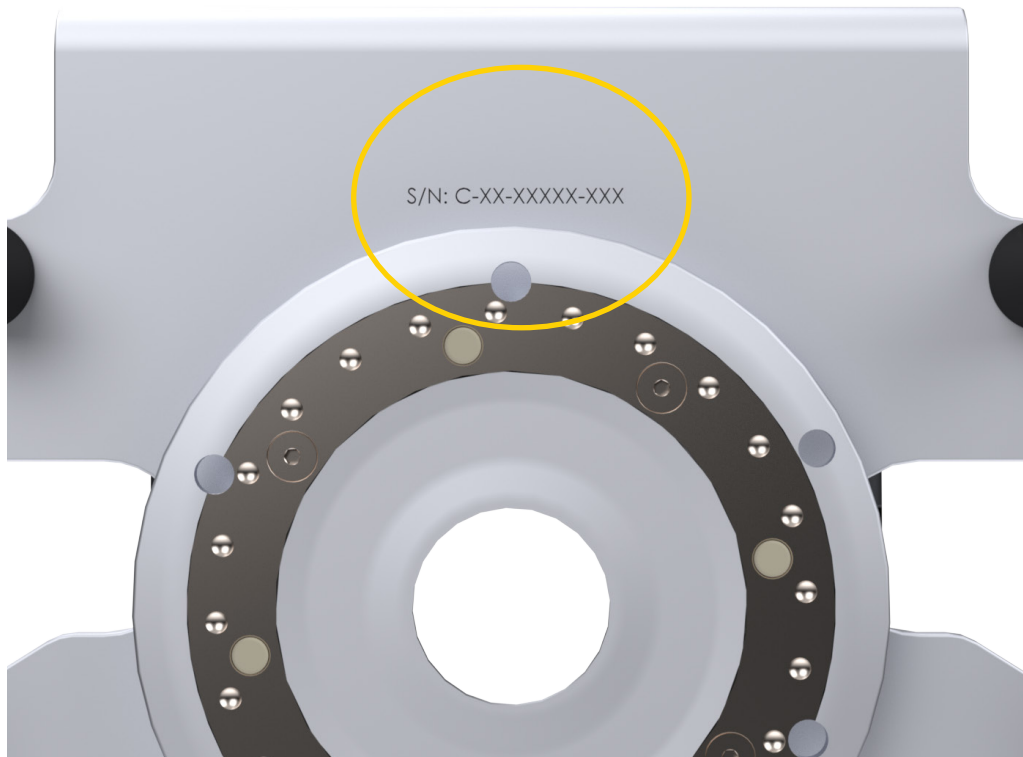





TABLE OF CONTENTS

COPYRIGHT	2
CONTACT INFORMATION.....	3
SYMBOLS AND DEFINITIONS	6
WARNING / CAUTION / NOTE.....	7
PRODUCT ILLUSTRATION.....	8
<i>BRACKET PRO SERIE 60-SD</i>	8
<i>FRONT VIEW</i>	8
<i>BACK VIEW</i>	9
INTRODUCTION	10
PURPOSE OF THE DOCUMENT	10
PRODUCT DESCRIPTION	10
INTENDED USE OF THE PRODUCT	10
POSSIBLE MOUNTING OPTIONS FOR THE BRACKET PRO SERIE 60-SD.....	11
TECHNICAL SPECIFICATIONS.....	12
SUMMARY OF SAFETY PRECAUTIONS	13
WARNING/CAUTION/NOTE	13
INSTALLATION GUIDE	16
REMOVING THE PACKAGING FOR INSTALLATION.....	16
INSTALLATION OF THE BRACKET ONTO THE HAMILTON T1 VENTILATOR.....	17
GENERAL OPERATING GUIDELINES FOR THE SAFETY ARM SYSTEM	19
OPERATING THE BRACKET ON THE SAFETY ARM SYSTEM	20
<i>INSTALLING THE BRACKET ONTO THE STANDARD SURFACE BASE</i>	20
<i>ROTATING THE BRACKET ON THE STANDARD SURFACE BASE</i>	20
<i>REMOVING THE BRACKET FROM THE STANDARD SURFACE BASE</i>	21
PART NUMBERS	22
KITS AND OTHER OPTIONS	22
MAINTENANCE GUIDE.....	23
CLEANING	23
<i>CLEANING PROCESS</i>	23
<i>REMOVAL OF IODINE COMPOUNDS</i>	24
PREVENTIVE MAINTENANCE.....	24
INSPECTION PROCESS AND SCHEDULE.....	25
<i>MAINTENANCE PROGRAM</i>	25
INSPECTION AND MAINTENANCE RECORD.....	26
TRAINING RECORD.....	27
REPLACEMENT PARTS.....	28
WARRANTY	29
WARRANTY POLICY.....	29
LIMITED RESPONSIBILITY AND WARRANTY.....	29
INTERNATIONAL WARRANTY CLAUSE	29
RETURN POLICY	30
RETURN POLICY.....	30
<i>PRIOR TO 30 DAYS</i>	30
<i>PRIOR 45 DAYS</i>	30
<i>PRIOR 60 DAYS</i>	30

TABLE OF CONTENTS



RETURN AUTHORIZATION.....	30
DAMAGED MERCHANDISE.....	31
CLAIM PROCESS	31
<i>REQUIRED INFORMATION</i>	31
<i>FINDINGS AND CONCLUSION</i>	31
QUESTIONS ABOUT OUR POLICY	31
SAE CERTIFICATION	32

SYMBOLS AND DEFINITIONS

<u>SYMBOL</u>	<u>DESCRIPTION</u>
	Warning and Caution, special attention is required. Consult accompanying documents
	Safe working load symbol and Load balance symbol
	Pinch Point

WARNING / CAUTION / NOTE

The word warning, caution, or note carry special meaning and should be carefully reviewed.

<u>SYMBOL</u>	<u>DESCRIPTION</u>
	<p>WARNING</p> <p>Alerts the reader about a situation which, if not avoided, could result in death or serious injury. It may also describe potential serious adverse reactions and safety hazards.</p>
	<p>CAUTION</p> <p>Alerts the reader of a potentially hazardous situation, which, if not avoided, may result in minor or moderate injury to the user or patient or damage to the equipment or other property. This includes special care necessary for the safe and effective use of the device to avoid damage that may occur as a result of use or misuse.</p>
NOTE	<p>Provides special information about the product.</p>

PRODUCT ILLUSTRATION

[BRACKET PRO SERIE 60-SD](#)

[Front View](#)

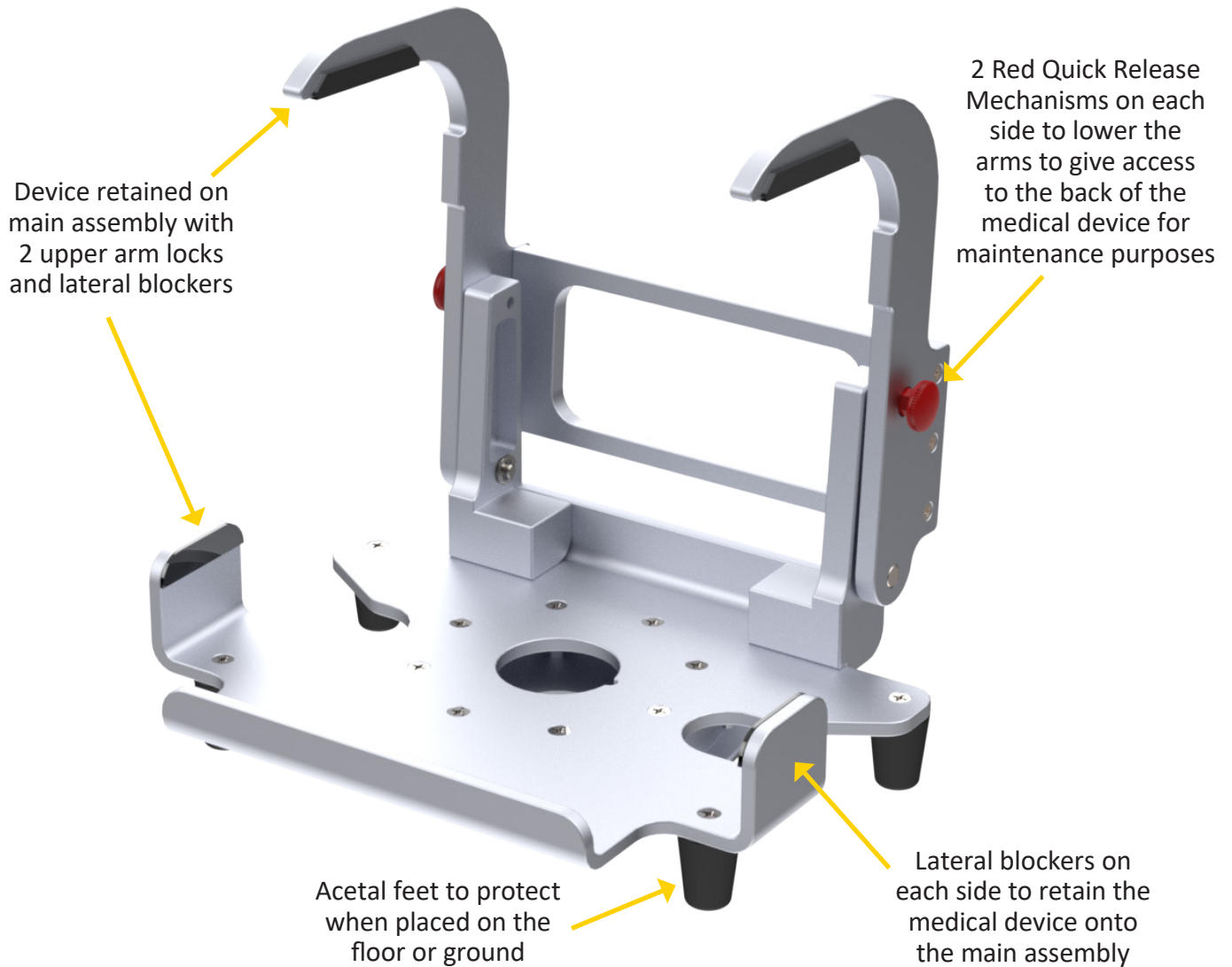

PRODUCT ILLUSTRATION (CONTINUED)

[BRACKET PRO SERIE 60-SD \(CONTINUED\)](#)

[Back View](#)

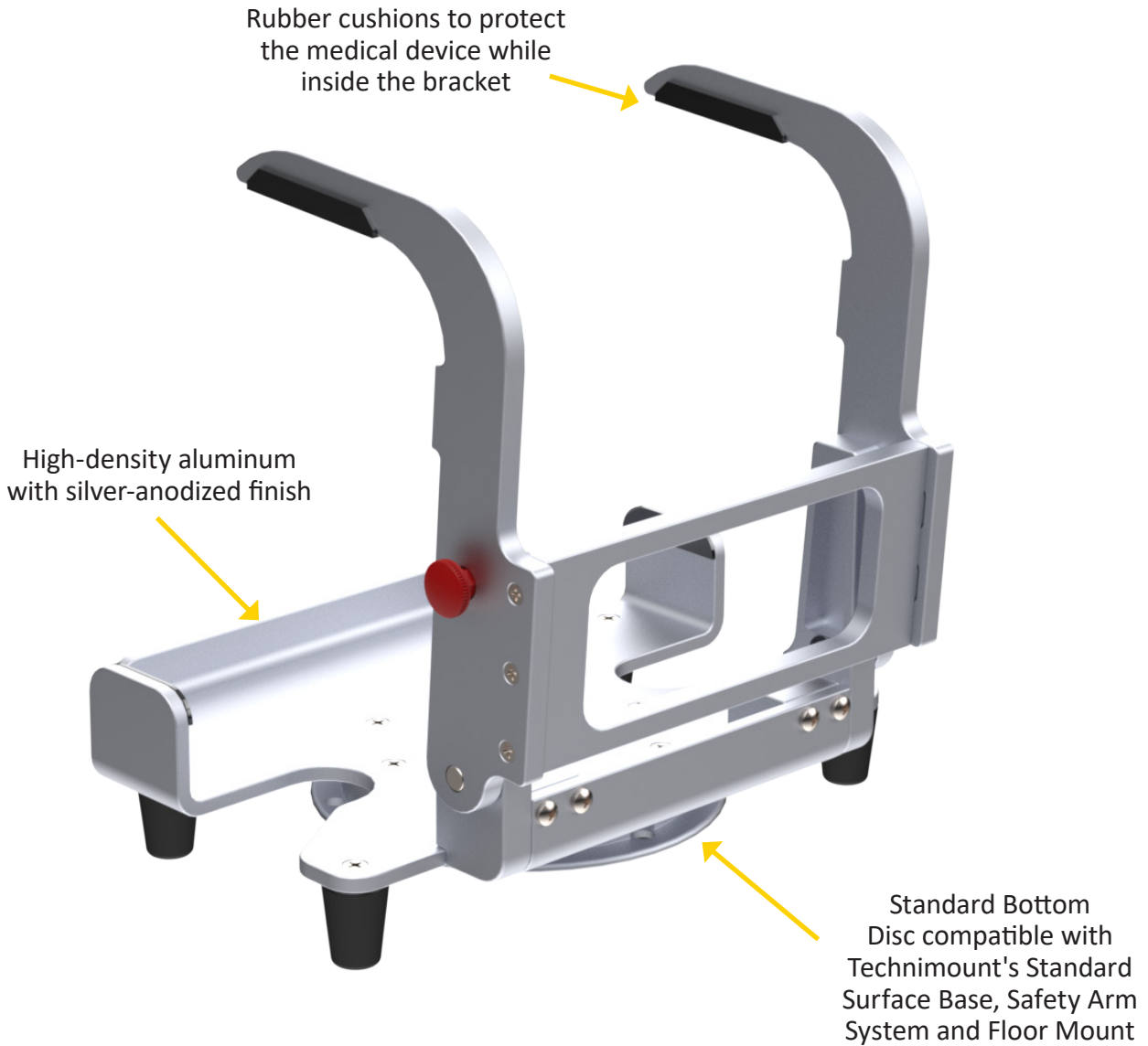

PURPOSE OF THE DOCUMENT

This user guide is designed to assist you with the installation, operation and maintenance of the Bracket Pro Serie 60-SD for the Hamilton T1 Ventilator from Hamilton Medical.

PRODUCT DESCRIPTION

The Bracket Pro Serie 60-SD is the only universal solution to mount the Hamilton T1 Ventilator from Hamilton Medical in different applications such as on surface, floor, and cot/stretchers systems. It can fit any ground and air ambulance configurations in North American and European markets. It is designed to securely support and transport the Hamilton T1 Ventilator in pre-hospital and hospital environments. When used in emergency vehicles with a cot/stretchers, the Bracket Pro Serie 60-SD can be positioned on Technimount's Safety Arm System, Standard Surface Base and Floor Mount. These solutions provide a higher flexibility for different EMS/CCT protocols and applications.

INTENDED USE OF THE PRODUCT

The Bracket Pro Serie 60-SD is a mounting solution to securely transport the Hamilton T1 Ventilator from Hamilton Medical during EMS/CCT. It is designed to be installed on the equipment as described in this user guide. The Bracket Pro Serie 60-SD is for crew who has received the appropriate training necessary to operate the equipment in the field according to its intended use as outlined in this user guide. Please read this user guide thoroughly before using this equipment. To ensure the safe operation of this equipment, it is recommended to train staff prior to use.

INTRODUCTION

POSSIBLE MOUNTING OPTIONS FOR THE BRACKET PRO SERIE 60-SD

Safety Arm System



Standard Surface Base

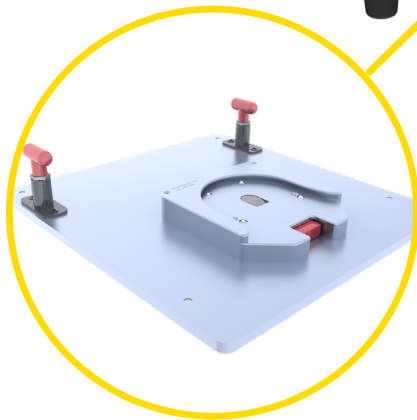
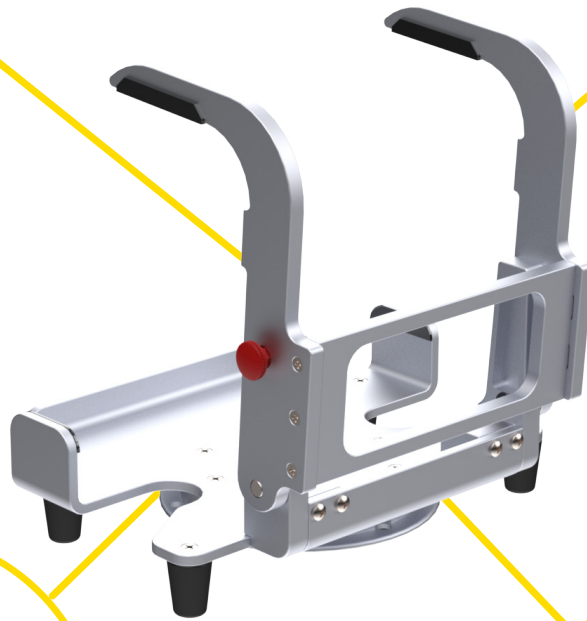

Floor Mount
Air Ambulance

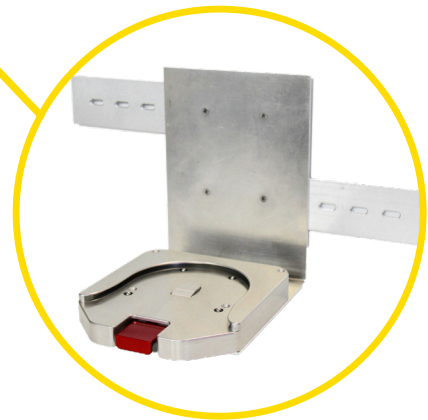

Wall Mount System

[Return To Table of Contents](#)

INTRODUCTION

TECHNICAL SPECIFICATIONS

Product Name	Bracket Pro Serie® 60-SD
Product Description	Single disc bracket mounting system to secure the Hamilton-T1 ventilator on surfaces and cots/stretchers in emergency vehicles
Compatibility of Medical Device*	Hamilton-T1 Ventilator from Hamilton Medical
Environment of Usage	EMS/CCT (Ground & Flight) – Hospital/Clinic, Military
Product Section Material	<ul style="list-style-type: none">• Main Assembly: Aluminum 6061-T6• Standard Bottom Disc: Aluminum 6061-T6 with 304 Stainless Steel Insert
Product Finish	<ul style="list-style-type: none">• Main Assembly: Silver-Anodized Finish• Standard Bottom Disc: Silver-Anodized Finish
Environmental Regulations	Complying with RoHS 3
Temperature of Usage	- 35° C to 45° C
Certification	<p>Tested in Compliance with:</p> <ul style="list-style-type: none">• SAE J3043 (26 G)• FAA, 14 CFR § 23 (applicable standards) <p>Designed to Comply with:</p> <ul style="list-style-type: none">• EN 1789 (10G)
Installation	Device Retained on Main Assembly with 2 upper arms with Red Quick Release Mechanisms and lateral blockers
Attachment Options	Standard Bottom Disc
Transportation Compatibility System	<p>Compatible with Technimount's:</p> <p>Standard Surface Base</p> <ul style="list-style-type: none">• Safety Arm System For Stryker Cots (PowerPro – XT and Mx-Pro)• Floor Mount (Flight)
Features	<ul style="list-style-type: none">• Robust Mounting Solution for EMS/CCT/ALS Transport• No Screw or Attachment into the Housing of the Medical Device• Access to all Connectors and Accessories• Flight and Ground Compatibility• Multiple Configuration Options for Transport
Physical Overall Dimensions	Width 11.5 in, Depth 10.2 in, Height 11.5 in
Weight	5.8 lb
Part Number	<ul style="list-style-type: none">• 700-12-HMSD - Bracket Pro Serie® 60-SD• 100-20-UN - Standard Surface Base
Others Models and Configuration Options	Contact Technimount EMS for more information or for other options at customerservice@technimount.com

* Product and medical equipment manufacturers names are trademarks™ or registered trademarks® of their respective holders. Technimount does not have a commercial relationship with these medical equipment manufacturers.

SUMMARY OF SAFETY PRECAUTIONS

WARNING/CAUTION/NOTE

Carefully read and strictly follow all Warnings and Cautions listed in this user guide. Servicing and maintenance should only be done by qualified personnel.

WARNING

- ✓ Always hold the Bracket with both hands when you manipulate it.
- ✓ Operate the bracket only as described in this user guide.
- ✓ Do not modify the bracket, or any components of Technimount systems. Modifying the product can cause unpredictable operation resulting in injury to the patient or operator.
- ✓ It is the responsibility of the operator of the bracket or any of its options, to ensure equipment being used with the Technimount products meets the installation specifications. Injury may result if non-compatible products are used with Technimount products.
- ✓ Do not attempt to operate, install or remove the equipment while mobile. Ensure that installation and removal of equipment is done while vehicle or aircraft is immobilized.
- ✓ Verify that the bracket is inserted correctly into a mounting system and locked. If equipment is improperly installed and locked, it can cause the equipment to fall and cause injury to the patient or operator and/or damage to the medical equipment.
- ✓ Never use the bracket if not properly installed and locked on a base, a cot/stretchers, or on a wall mount or floor mount. If not installed properly, the medical device could fall during transport and may cause injury to the patient or operator and/or damage to the product.
- ✓ Do not allow untrained staff to assist in the operation of the mounting system. Untrained technicians/staff can cause injury to the patient or themselves.
- ✓ Do not place additional equipment or items onto the bracket or mounts other than approved Technimount or components, as this could damage the product and may result in injury to the patient or operator.
- ✓ Operators must be able to safely lift the total weight of the bracket system and medical device.
- ✓ Do not attach restraints to the Bracket frame. It may result in damage to the system and/or result in injury to the patient or operator.
- ✓ Always reposition the equipment with care, avoid any improper pushing or violent manipulation, as it may result in unbalanced equipment and may cause injury to the patient or operator and/or damage to the product.
- ✓ Improper maintenance can cause injury to patient or operator or damage to the product. Maintain the bracket and mounting systems as described in this user guide. Use only Technimount approved parts and maintenance procedures. Using unapproved parts and procedures could cause unpredictable operation and/or injury and will void the product warranty.
- ✓ Failure to properly clean or dispose of corrosive products will increase the risk of premature damage and may cause injury to the patient or operator.
- ✓ Any installation on a surface or on the structure of the vehicle or the aircraft has to be validated or inspected in order to ensure it maintains the integrity of the vehicle or the aircraft.

SUMMARY OF SAFETY PRECAUTIONS

WARNING/CAUTION/NOTE (CONTINUED)

CAUTION

- ✓ Only certified technical personnel familiar with the bracket installation and use should manipulate it. Always refer to Technimount's user guides for all instructions for installing and using any Technimount Mounting System.
- ✓ Inspect regularly all components on the equipment for any issue and loose screws, bolts and nuts.
- ✓ Never install the mount into or on other similar mounting systems or brackets without written confirmation by Technimount as these different systems may be from other brands or models and may not be compatible with Technimount systems.

NOTE

- ✓ Some cleaning products are corrosive in nature and may cause damage to the product if used improperly. If such products are used to clean Technimount equipment, the equipment must be rinsed with clean water and thoroughly dried following the cleaning. Failure to properly rinse and dry the mounting systems will leave a corrosive residue on the surface, possibly causing premature corrosion of critical components.
- ✓ When ordering, it is important to identify on which mounting system you need to mount the bracket on as there are different systems for different applications (ground).
- ✓ A maintenance program should be established for all Technimount equipment. Preventive maintenance may need to be performed more frequently, based on the level of use of the product. Close attention should be given to safety features (i.e.: screws, quick release mechanisms, and attachment points).
- ✓ Failure to use authorized parts, and lubricants, could cause damage to the equipment and will void the warranty of the product.
- ✓ This user guide should be considered a permanent part of the Bracket, and should remain with the product even if the equipment is subsequently sold.
- ✓ Technimount continually seeks advancements in product design and quality. Therefore, while this user guide contains the most current product information available at the time of printing, there may contain minor differences between your mounting system and this user guide.

If you have any questions, or for more information, please contact Technimount Customer Service customerservice@technimount.com.

NOTICE/CERTIFICATION

The Bracket Pro Serie 60-SD is tested in compliance with the essential requirements and other relevant provisions of the Directive 1999/5/EC and SAE J3043. For more information, please contact Technimount Customer Service (customerservice@technimount.com).

Technimount E.M.S. Holding Inc.

C/O: Regulatory Affairs

3770 Jean Marchand Street, Suit 100-C

Quebec (QC) G2C 1Y6

Canada

T + 1 888.639.2758

F + 1 855.339.6351

technimount.com

info@technimount.com



WARNING

The end user and administrator are responsible to validate regulations and standards for safety in their region, in order to comply with applicable safety regulations. Technimount is not responsible to inform the end user and /or the administrator of applicable legislation for safety in their area.

REMOVING THE PACKAGING FOR INSTALLATION

1. Unpack boxes and check all items are included for installation.
2. Ensure that all shipping and packaging materials have been properly removed from the product(s) prior to installation.
3. Identify all of the product components and hardware prior to starting the installation.
4. The bracket must work properly before being put into service.
5. Refer to the identification of components at the beginning of this user guide if needed.

INSTALLATION OF THE BRACKET ONTO THE HAMILTON T1 VENTILATOR

1. The Bracket Pro Serie® 60-SD is designed to be installed on the Hamilton T1 Ventilator.



2. Place bracket on a stable and large surface.
3. Pull the two (2) Red Quick Release Mechanisms outwards on each side of the bracket to unlock the arms.



4. Gently lower the bracket all the way down onto its back.



INSTALLATION OF THE BRACKET ONTO THE HAMILTON T1 VENTILATOR (CONTINUED)

5. Place the Hamilton T1 inside the bracket.



6. Pull on the Red Quick Release Mechanisms and raise the arms towards the front of the medical device to close and lock the arms into upper position.

7. Release the Red Quick Release Mechanisms.

WARNING

Ensure both arms are securely locked into upper position prior to transport or mobilizing with the equipment. If incorrectly locked it could cause injury to the patient or operator and damage to the equipment.

8. The medical device and bracket are now ready for transport.



GENERAL OPERATING GUIDELINES FOR THE SAFETY ARM SYSTEM

- ✓ Use the Safety Arm System only as described in its user guide.
- ✓ Read all the labels and instructions on the product before using the Safety Arm System.
- ✓ Always inspect the Clamp Block, Safety Pin, Lock Pin, and Standard Surface Base before every use.
- ✓ Installing or removing the Safety Arm System requires a minimum of one (1) trained operator.
- ✓ Do not remove the Safety Arm System or device from the system while moving with the cot/stretcher.
- ✓ Stay with the patient and control the Safety Arm System and device during transport at all times.



WARNING

- ✓ Never let a patient grab, manipulate or hold the Safety Arm System, the Standard Surface Base or bracket on the cot/stretcher because it may cause injury to the operator or patient. Secure the Safety Arm System and bracket as recommended while the patient is on the cot/stretcher.

OPERATING THE BRACKET ON THE SAFETY ARM SYSTEM

INSTALLING THE BRACKET ONTO THE STANDARD SURFACE BASE

1. Only Technimount brackets with a Standard Bottom Disc can be inserted into the Standard Surface Base located on the Safety Arm System.
2. To insert the bracket into the Standard Surface Base, slide into the base horizontally from the front of the base.
3. Ensure the bracket is locked securely in the Standard Surface Base before manipulating the device or transporting the stretcher.



ROTATING THE BRACKET ON THE STANDARD SURFACE BASE

1. To rotate the medical device 360°, turn the bracket inside the Standard Surface Base clockwise or counter clockwise to use the device in the desired position.



OPERATING THE BRACKET ON THE SAFETY ARM SYSTEM (CONTINUED)

REMOVING THE BRACKET FROM THE STANDARD SURFACE BASE

1. To remove the bracket from the Safety Arm System, press the Red Quick Release Mechanism located on the front Standard Surface Base.
2. While holding the Red Quick Release Mechanism, slide outwards horizontally to remove from the Standard Surface Base. Hold the ventilator from the middle of the unit to gently remove from the base.



PART NUMBERS

KITS AND OTHER OPTIONS

<u>DESCRIPTION</u>	<u>PART NUMBER</u>
Bracket Pro Serie 60-SD	700-12-HMDC
Floor Mount	554-20-AB-FL
Standard Surface Base	100-20-UN
Safety Arm System	Several Models Available, refer to Customer Service

WARNING

Do not modify any components of this system. Modifying the product can cause unpredictable operation resulting in injury to the patient or operator.

NOTE

Technimount reserves the right to change Part Numbers and Products without notice. Please refer to Customer Service to ensure product part number availability.

For any replacement parts or for repair, please contact Technical Support at techsupport@technimount.com

CLEANING

CLEANING PROCESS

WARNING

ENSURE TO REMOVE MEDICAL DEVICE FROM THE BRACKET IF THOROUGH CLEANING IS NEEDED.

Follow your EMS service's protocol or medical device manufacturer's user guide for the recommended cleaning procedure of your medical devices. Cleaning procedure below does NOT provide recommendations for cleaning of the medical device. The following cleaning guidelines consider the Technimount mounting assemblies and components.

It is the responsibility of each EMS service to use the cleaning solution of their choice. All EMS service's have policies and procedures describing how they should clean and disinfect their medical equipment. Use a chlorine bleach solution (3.25% - less than one part bleach to 100 parts water), a solution containing alcohol, phenolic cleaners (active ingredient - o-phenyl phenol) or a quaternary ammonium chloride solution. In diluted concentrations, these cleaning agents have no negative effect on our products.

The bracket can be cleaned by using a pressure washer. The bracket may show some signs of oxidation or discoloration from continuous washing, however, degradation of the product's performance or functionality will not be affected due to power washing if cleaning instructions are properly followed.

The material used to manufacture the bracket is high-grade aluminum, it is very durable and resistant to corrosion, however high levels of sodium or a high concentration of sodium or acid may prematurely corrode the product. Always rinse with soft soap and water if exposed.

- ✓ Use of a power washer can accelerate removal of contaminants collected during the use of the product.
- ✓ Rinse with clean water.
- ✓ Towel dry all components.
- ✓ Allow all other components to air dry.
- ✓ Avoid over saturation and ensure that the product does not stay wet longer than the cleaner manufacturer's guidelines for proper disinfecting.

WARNING

- ✓ When cleaning, always use appropriate personal protection equipment (PPE) based on established protocols (e.g., gloves, eye wear, etc.).

CAUTION

- ✓ Do not steam clean or use ultrasonic cleaners on the system or any of its components.
- ✓ Do not immerse the metal parts/components in water.
- ✓ Maximum water temperature should not exceed 180°F/82°C.
- ✓ Maximum water pressure should not exceed 500 psi/34,5 BAR. If a pressure washer is being used to clean the unit, the pressure nozzle must be kept a minimum of 24 inches (61 cm) from the unit.

MAINTENANCE GUIDE

CLEANING (CONTINUED)

CLEANING SOLUTIONS

Phenolic type or quaternary type disinfectants can be used (excluding Virex® TB). Iodophor type disinfectants, Peracetic Acid, Chlorine, and especially Hydrogen Peroxide are not recommended for use because staining and corrosion may result.

Suggested cleaners for the bracket:

- ✓ Quaternary Cleaners (active ingredient - ammonium chloride)
- ✓ Water and soft soap
- ✓ A mild 10% bleach solution, a solution containing alcohol or a quaternary ammonium chloride solution. In diluted concentrations, these cleaning agents have no negative effect on our products.

WARNING

- ✓ Some cleaning products are corrosive in nature and may cause damage to the product if used improperly.
- ✓ If the products described are used to clean the equipment, the bracket and components must be rinsed with clean water and thoroughly dried following cleaning. Failure to properly rinse and dry the system will leave a corrosive residue on the surface of the product, possibly causing premature corrosion of critical components.

REMOVAL OF IODINE COMPOUNDS

If rust appears on any surface of the product, we recommend sanding the affected surface to remove the rust and then using the cleaning method presented in this guide once the rust is removed. To clean the stained area, use a solution of 1/4 Tablespoon of Sodium Thiosulfate in 1 pint / .5 litre of warm water to clean the stained area. Clean as soon as possible after staining occurs. If stains are not immediately removed, allow solution to soak or stand on the surface. Thoroughly rinse surfaces with clean water and allow to air dry before returning unit to service.

WARNING

- ✓ Failure to properly clean contaminated parts or components will increase the risk of exposure to blood borne pathogens and may cause injury to the patient or the operator.

PREVENTIVE MAINTENANCE

A preventive and regular maintenance program should be established for all Technimount equipment. Preventive maintenance may be required more frequently based on the usage level of the product. The bracket requires regular preventative maintenance. Establish and follow a preventive maintenance schedule and keep records of preventive maintenance activities (see maintenance form in this user guide).

CAUTION

- ✓ Close attention should be given to safety features including, but not limited to locking mechanisms and discs.
- ✓ Improper maintenance can cause injury or damage to the product. Maintain the product as described in this user guide.

MAINTENANCE GUIDE

INSPECTION PROCESS AND SCHEDULE

MAINTENANCE PROGRAM

The following inspection routine and schedule is intended as a general guide for preventive maintenance of the Bracket. Factors such as weather, environment, geographical location, and individual usage will necessitate different maintenance. If you are unsure as to how to perform these maintenance inspections or at what interval to perform these inspections, please contact your Technical Support Team at techsupport@technimount.com. Check each routine and replace damaged or worn out parts if necessary.

Follow timetable below for maintenance (either in months (M) or hours (H)), in accordance with your Service's current maintenance practices and protocols.

<u>ITEM</u>	<u>ROUTINE</u>	<u>1 M</u> <u>OR</u> <u>2 H</u>	<u>3 M</u> <u>OR</u> <u>6 H</u>	<u>6 M</u> <u>OR</u> <u>12 H</u>	<u>12 M</u> <u>OR</u> <u>24 H</u>
Bracket	<ul style="list-style-type: none"> ✓ Inspect Bracket <ul style="list-style-type: none"> ▪ Inspect the screws of the bracket ▪ Inspect the bottom screw that tightens into the medical device ▪ Ensure bracket mechanisms are working properly and there are no particles, obstacles, or debris affecting functionality ✓ Verify Disc is clean and working properly ✓ Ensure Red Quick Release Mechanisms are working properly (pull to release and then lock) ✓ Ensure arms are locking into position properly ✓ Do a visual inspection of the Bracket to ensure there is no damage or chemical attack 	X			

MAINTENANCE GUIDE

INSPECTION AND MAINTENANCE RECORD

PREVENTIVE MAINTENANCE PERFORMED	BY	DATE	TIME

MAINTENANCE GUIDE

TRAINING RECORD

<u>TRAINEE NAME</u>	<u>TRAINING DATE</u>		<u>TRAINING METHOD USER GUIDE, IN-SERVICE, IN-CLASS, ETC.</u>
	<u>BASIC TRAINING</u>	<u>TRAINING UPDATE</u>	

MAINTENANCE GUIDE

REPLACEMENT PARTS

The parts and accessories listed are all currently available for purchase. Some of the parts identified on the assembly drawing parts in this user guide may not be individually available for purchase. Please call Technimount Customer Service : +1 888.639.2758 or customerservice@technimount.com for availability and pricing.

<u>DESCRIPTION</u>	<u>PART NUMBER</u>
Bracket Pro Serie 60-SD	700-12-HMSD
Standard Bottom Disc	926-00-SS
Acetal Feet	TCM-032-082

WARRANTY POLICY

This statement constitutes TECHNIMOUNT's entire warranty policy with regards to the TECHNIMOUNT Products.

TECHNIMOUNT MAKES NO OTHER WARRANTY OR REPRESENTATION NEITHER EXPRESSED NOR IMPLIED, EXCEPT AS SET FORTH HEREIN. THERE IS NO WARRANTY OF MERCHANTABILITY AND THERE ARE NO WARRANTIES OF FITNESS FOR ANY PARTICULAR PURPOSE. IN NO EVENT SHALL TECHNIMOUNT BE LIABLE HEREUNDER FOR INCIDENTAL OR CONSEQUENTIAL DAMAGES ARISING FROM OR IN ANY MANNER RELATED TO SALES OR USE OF ANY SUCH EQUIPMENT.

TECHNIMOUNT E.M.S. Holding Inc. (TECHNIMOUNT) guarantees to the original "Purchaser" of the "Hardware" with which this "Limited Warranty" is included that the Hardware will be free from "Defects" in workmanship and materials under normal use for a "Warranty Period", one (1) year from the date that the Hardware was first purchased by the Purchaser. During the Warranty Period, the Hardware will be repaired or replaced according to the "Limited Warranty" without charge to the Purchaser for either parts or labor. The parts may be repaired or replaced with either new or refurbished parts. The product may be replaced for a new or refurbished product. For this Limited Warranty "refurbished" means parts and products, which have been returned to factory specifications. If the Hardware is repaired or replaced within the Warranty Period, the greater of the remaining warranty period will apply or three (3) months from the date of repair/replacement. If the Hardware is repaired or replaced after the Warranty Period has expired, the Warranty Period for the repair or replacement will expire three (3) months after the date of repair or replacement.

LIMITED RESPONSIBILITY AND WARRANTY

The Limited Warranty does not apply to normal wear that should result from normal use. It does not apply when the Hardware or any component is opened, disassembled, or repaired by someone not authorized by TECHNIMOUNT and does not cover repair or replacement of any Hardware or part thereof damaged by neglect, misuse, moisture, liquids, exposure to heat, accidents, abuse, and non-compliance with the instructions for installation and use provided with the Hardware. The Limited Warranty does not cover physical damage to the surface of the Hardware, and the decision to repair, replace or refuse the coverage is final and its sole discretion of TECHNIMOUNT, and is made without any compensation or obligation from TECHNIMOUNT.

The hardware, or product defined as a mounting or bracket system for clipping and attaching medical equipment is specifically designed to fill this requirement. Any other use will void the warranty and TECHNIMOUNT will not be held liable on any claim if the product is modified or adapted for use.

Technimount products are intended to retain a medical device in place in the case of a single crash impact. A Technimount product must NOT be used again if it was involved in a crash. The product MUST be replaced. If the Purchaser uses a Technimount product following a crash, it is at the Purchaser's own risk and Technimount will not be held liable.

INTERNATIONAL WARRANTY CLAUSE

This warranty reflects Canadian domestic policy. Warranty outside Canada may vary by country. Please contact TECHNIMOUNT Customer Service for more information.

RETURN POLICY

RETURN POLICY

Mounting systems and bracket systems for portable medical devices may be returned up to 60 days of receipt if:

- The product is not what was originally ordered
- The product does not meet specifications with TECHNIMOUNT's technical sheets according to the customer
- The product is not compatible with the equipment on which it was to be installed

For any manufacturing defect, refer to the conditions of the Warranty Policy.

PRIOR TO 30 DAYS

- Product must be undamaged and in its original packaging
- The product return request must be provided in writing and it must be approved by TECHNIMOUNT prior to returning the product
- Returns will not be approved on a modified or damaged item
- Charges may apply if damaged or missing item
- Customer is responsible for a 10% restocking fee

PRIOR 45 DAYS

- Product must be unused, undamaged and in its original packaging
- The product return request must be provided in writing and it must be approved by TECHNIMOUNT prior to returning the product
- Returns will not be approved on modified or damaged item
- Charges may apply if damaged or missing items
- Customer is responsible for a 25% restocking fee

PRIOR 60 DAYS

- Product must be unused, undamaged and in its original packaging
- The product return request must be provided in writing and it must be approved by TECHNIMOUNT prior to returning the product
- Returns will not be approved on a modified or damaged item
- Charges may apply if damaged or missing items
- Customer is responsible for a 30% restocking fee

RETURN AUTHORIZATION

TECHNIMOUNT's customer service department is responsible for approving any merchandise return and will provide a Return Merchandise Authorization (RMA) number to be printed on any returned merchandise. TECHNIMOUNT reserves the right to charge shipping and restocking fees on returned items. SPECIAL, MODIFIED, OR DISCONTINUED ITEMS NOT SUBJECT TO RETURN.

RETURN POLICY

DAMAGED MERCHANDISE

ICC Regulations require that claims for damaged merchandise must be made with the carrier within fifteen (15) days of receiving merchandise. DO NOT ACCEPT DAMAGED SHIPMENTS UNLESS SUCH DAMAGE IS NOTED ON THE DELIVERY RECEIPT AT THE TIME OF RECEIPT. Upon prompt notification, TECHNIMOUNT will file a freight claim with the appropriate carrier for damages incurred. Claim will be limited in amount to the actual replacement cost. In the event that this information is not received by TECHNIMOUNT within the fifteen (15) day period following the delivery of the merchandise, or the damage was not noted on the delivery receipt at the time of receipt, the customer will be responsible for payment of the original invoice in full.

Note: Claims for any short or broken shipment must be made within thirty (30) days of invoice.

CLAIM PROCESS

Please follow the claim procedure below to return a defective product:

Fill in the RMA form online at <https://www.technimount.com/service-support/service-support-overview/>

REQUIRED INFORMATION

- Serial number
- Invoice number
- Identification of the issue
- Upload the pictures of the issue
- Submit the form

A confirmation of the receipt of the claim will be sent to you within 2 business days. If you have not received a confirmation email by then, please contact techsupport@technimount.com.

If the RMA request is approved, TECHNIMOUNT will provide you with an RMA number for your claim. We will also include instructions for the replacement of your product. No product return will be accepted without the RMA number labeled on the outside of the box being returned.

FINDINGS AND CONCLUSION

- If following an investigation, we find that our product is defective, TECHNIMOUNT will take corrective actions and close the claim
- If following an investigation, we find that our product is NOT defective (misuse or abuse of the product) the product will not be covered by the warranty. Details of our findings and conclusions will be provided to you

QUESTIONS ABOUT OUR POLICY

If you have any questions regarding our return policy, please contact our Customer Service department at customerservice@technimount.com.

SAE CERTIFICATION





SAFETY AND FLEXIBILITY WHERE IT MATTERS MOST

TECHNIMOUNT E.M.S. HOLDING INC.
3770 Jean Marchand Street, Suite 100-C
Quebec (QC) G2C 1Y6
Canada
T + 1 888.639.2758
F + 1 855.339.6351
technimount.com
info@technimount.com

© 2021 Technimount E.M.S. Holding Inc. - All Rights Reserved
Printed in Canada



TECHNIMOUNT
EMS™