

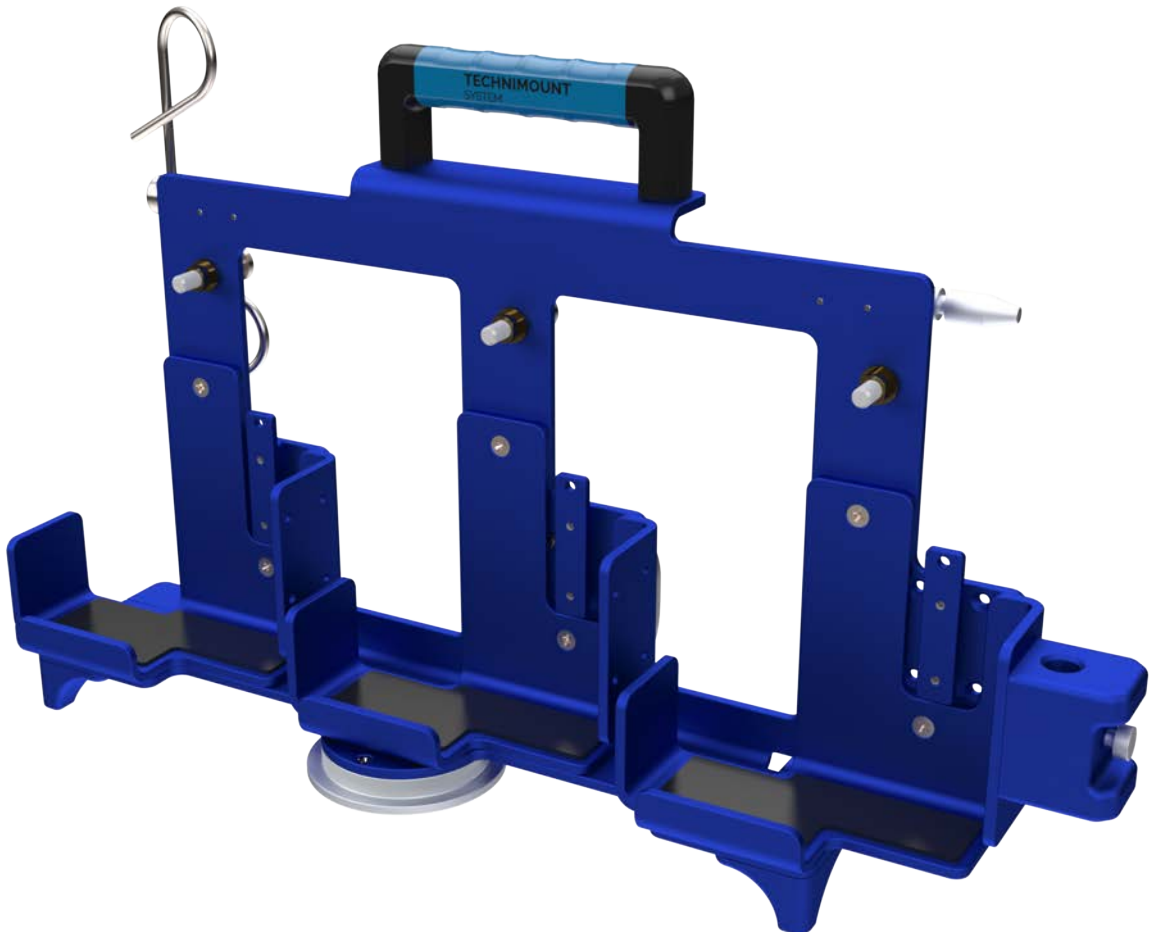

**TECHNIMOUNT**  
EMS™

# **BRACKET PRO SERIE® 121-FL**

## USER GUIDE



# COPYRIGHT

---

Copyright 2021 Technimount E.M.S. Holding Inc. (Technimount), an affiliated company of Technologies CGC Inc. All Rights Reserved. No part of this publication may be reproduced, transmitted, transcribed, stored in a retrieval system, or translated into any language in any form or by any means without the written permission of Technimount or its affiliate companies.

#### Trademark Attributions:

Bracket Pro Serie®, Technimount EMS™ are registered trade marks of Technologies CGC Inc.

Spectrum IQ® is a registered trademark from Baxter.

In order to ensure continuous improvements to our products and services, we invite you to communicate your comments to our Customer Service Department at [customerservice@technimount.com](mailto:customerservice@technimount.com). See Contact Information.

# CONTACT INFORMATION

---

## OFFICE ADDRESS

TECHMOUNT E.M.S. HOLDING INC.  
3770 Jean Marchand Street, Suite 100-C  
Quebec (QC) G2C 1Y6  
Canada

[info@technimount.com](mailto:info@technimount.com)

[www.technimount.com](http://www.technimount.com)

T + 1 888.639.2758

F + 1 855.339.6351

## NOTE:

For any issues with your Technimount product, its components, or for any technical questions during the installation or maintenance, please send an Email to [techsupport@technimount.com](mailto:techsupport@technimount.com).

Please have the serial number of your Technimount product available (as shown in the figure below) when calling Technimount Customer Service or Technical Support. Include the serial number in all written communications.

## SERIAL NUMBER LOCATION

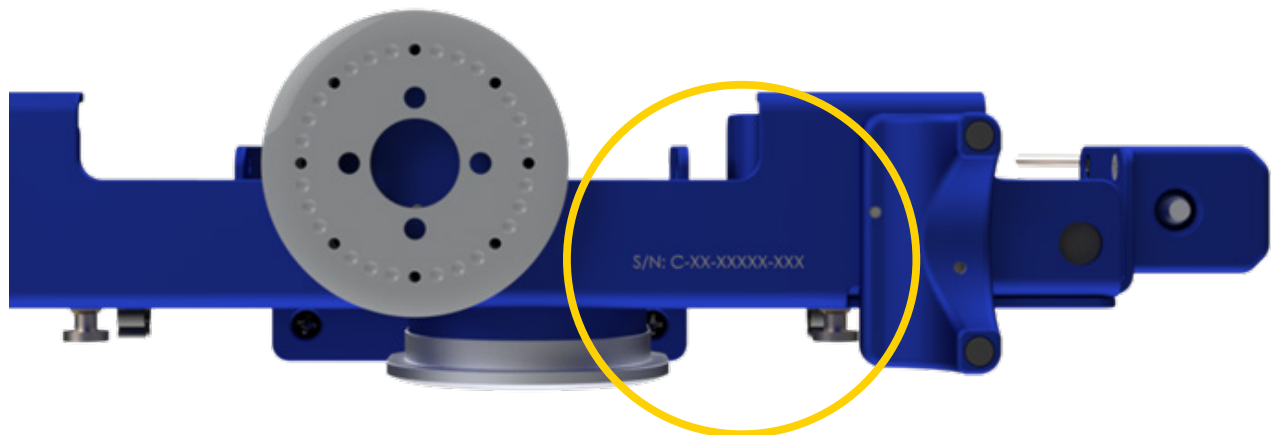

[Return To Table of Contents](#)

# TABLE OF CONTENTS

---

<b>COPYRIGHT .....</b>	<b>2</b>
<b>CONTACT INFORMATION.....</b>	<b>3</b>
<b>INTRODUCTION .....</b>	<b>6</b>
PURPOSE OF THE DOCUMENT .....	6
PRODUCT DESCRIPTION .....	6
INTENDED USE OF THE PRODUCT .....	6
POSSIBLE MOUNTING OPTIONS FOR THE BRACKET PRO SERIE® 121-FL .....	7
SYMBOLS AND DEFINITIONS .....	8
WARNING / CAUTION / NOTE.....	9
PRODUCT ILLUSTRATION.....	10
<i>BRACKET PRO SERIE 121-FL</i> .....	10
<i>FRONT VIEW</i> .....	10
<i>BACK VIEW</i> .....	11
SPECIFICATIONS.....	12
NOTICE .....	13
<b>SUMMARY OF SAFETY PRECAUTIONS .....</b>	<b>14</b>
WARNING/CAUTION/NOTE .....	14
<b>INSTALLATION GUIDE .....</b>	<b>16</b>
REMOVING THE PACKAGING FOR INSTALLATION .....	16
INSTALLATION OF THE BAXTER PUMPS ONTO THE BRACKET .....	17
<b>PART NUMBERS .....</b>	<b>20</b>
KITS AND OTHER OPTIONS .....	20
<b>MAINTENANCE GUIDE.....</b>	<b>21</b>
CLEANING THE BRACKET SYSTEM .....	21
<i>CLEANING PROCESS</i> .....	21
<i>CLEANING SOLUTIONS</i> .....	21
<i>REMOVAL OF IODINE COMPOUNDS</i> .....	22
PREVENTIVE MAINTENANCE.....	22
<i>LUBRICATION</i> .....	22
INSPECTION PROCESS AND SCHEDULE.....	23
<i>MAINTENANCE PROGRAM</i> .....	23
INSPECTION AND MAINTENANCE RECORD.....	24
TRAINING RECORD.....	25
REPLACEMENT PARTS.....	26
<b>WARRANTY .....</b>	<b>27</b>
WARRANTY POLICY .....	27
LIMITED RESPONSIBILITY AND WARRANTY.....	27
INTERNATIONAL WARRANTY CLAUSE.....	27
RETURN POLICY.....	28
<i>PRIOR TO 30 DAYS</i> .....	28
<i>PRIOR TO 45 DAYS</i> .....	28
<i>PRIOR TO 60 DAYS</i> .....	28
RETURN AUTHORIZATION.....	28
DAMAGED MERCHANDISE.....	29
CLAIM PROCESS .....	29

# TABLE OF CONTENTS

---

<i>REQUIRED INFORMATION</i> .....	29
<i>FINDINGS AND CONCLUSION</i> .....	29
QUESTIONS ABOUT OUR POLICY .....	29
<b>SAE CERTIFICATION</b> .....	<b>30</b>

## **PURPOSE OF THE DOCUMENT**

This User Guide is designed to assist you with the installation, operation and maintenance of the Technimount Bracket Pro Serie 121-FL that was designed for the Spectrum IQ Infusion System from Baxter®.

## **PRODUCT DESCRIPTION**

The Bracket Pro Serie 121-FL is a complete mounting system for Spectrum IQ Infusion System from Baxter in different applications such as on surface, floor, cot/stretchers and wall systems. It can fit any ground and air ambulance configurations in North American and European markets. It is designed to securely support and transport the Spectrum IQ Infusion System in pre-hospital and hospital environments. When used in emergency vehicles with a cot/stretchers, the Bracket Pro Serie 121-FL can be positioned on Technimount's Safety Arm System, on a Universal Standard Base, on a Safety MD-Transporter or with Technimount's Floor Mount or Wall Mount Systems. These solutions provide a higher flexibility for different EMS/CCT protocols and applications.

The Bracket Pro Serie 121-FL is compatible with the floor platform of air ambulances in Europe. It can also be used with the Wall Mount System for ground ambulances in Europe and North America. This mounting system is compatible with all of Technimount's products.

## **INTENDED USE OF THE PRODUCT**

The Bracket Pro Serie 121-FL is a mounting solution to securely transport the Spectrum IQ Infusion System during intra and inter-hospital transport. It is designed to be installed on the equipment as described in this user guide. This equipment is for crew who has received the appropriate training necessary to operate the equipment in the field according to its intended use as outlined in this user guide. Please read this User Guide thoroughly before using this equipment. To ensure the safe operation of this equipment, it is recommended to train staff prior to use.

# INTRODUCTION

## POSSIBLE MOUNTING OPTIONS FOR THE BRACKET PRO SERIE® 121-FL

Safety MD-Transporter



Wall Mount System (EU)

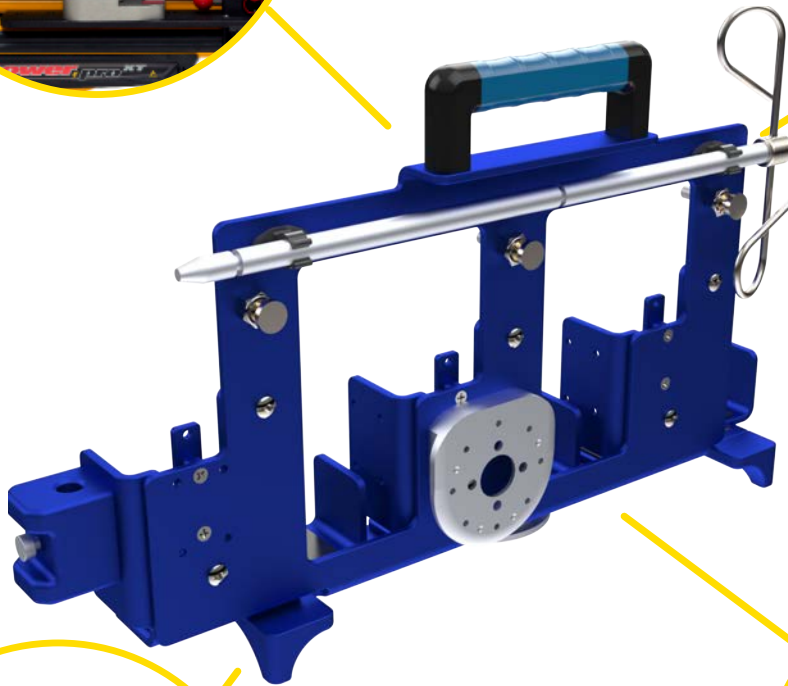
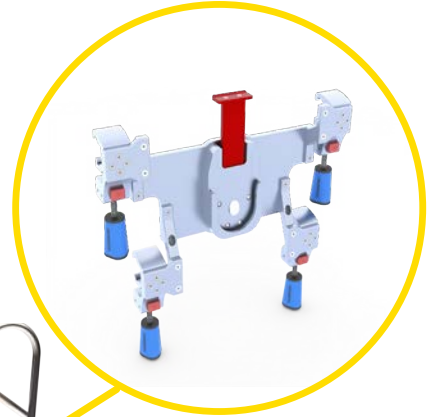



Safety MD-Transporter  
(Horizontal)



Proplate with 2 Micro  
Bases for IT Stretchers

[Return To Table of Contents](#)



## SYMBOLS AND DEFINITIONS

<u>SYMBOL</u>	<u>DESCRIPTION</u>
	Warning and Caution, special attention is required. Consult accompanying documents
	Safe working load symbol and Load balance symbol
	Pinch Point



## WARNING / CAUTION / NOTE

The word warning, caution, or note carry special meaning and should be carefully reviewed.

<u>SYMBOL</u>	<u>DESCRIPTION</u>
	<p><b>WARNING</b></p> <p>Alerts the reader about a situation which, if not avoided, could result in death or serious injury. It may also describe potential serious adverse reactions and safety hazards.</p>
	<p><b>CAUTION</b></p> <p>Alerts the reader of a potentially hazardous situation, which, if not avoided, may result in minor or moderate injury to the user or patient or damage to the equipment or other property. This includes special care necessary for the safe and effective use of the device to avoid damage that may occur as a result of use or misuse.</p>
<b>NOTE</b>	<p>Provides special information about the product.</p>

# INTRODUCTION

## PRODUCT ILLUSTRATION

### [BRACKET PRO SERIE 121-FL](#)

#### [Front View](#)

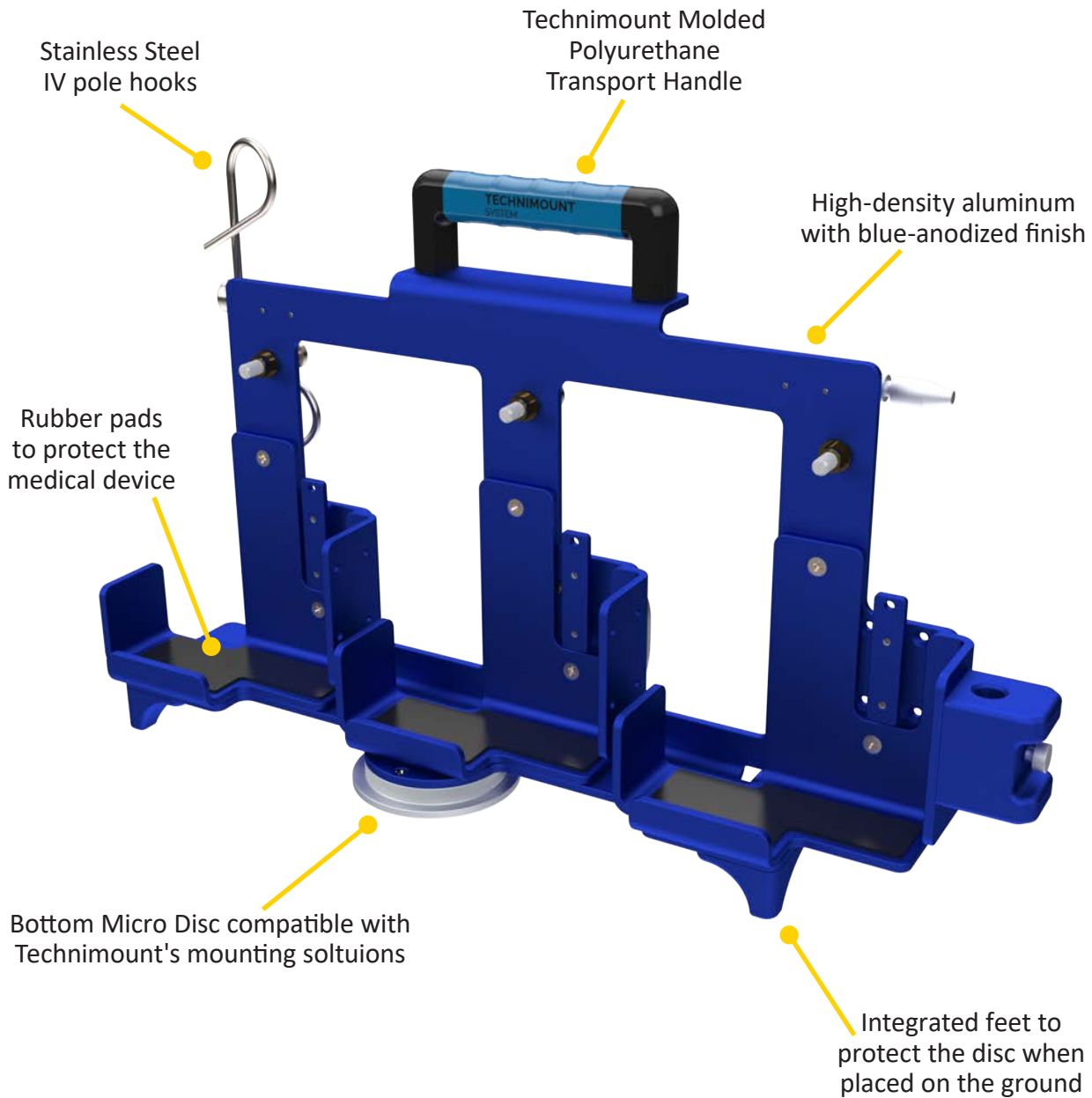

## PRODUCT ILLUSTRATION (CONTINUED)

### BRACKET PRO SERIE 121-FL (CONTINUED)

#### [Back View](#)

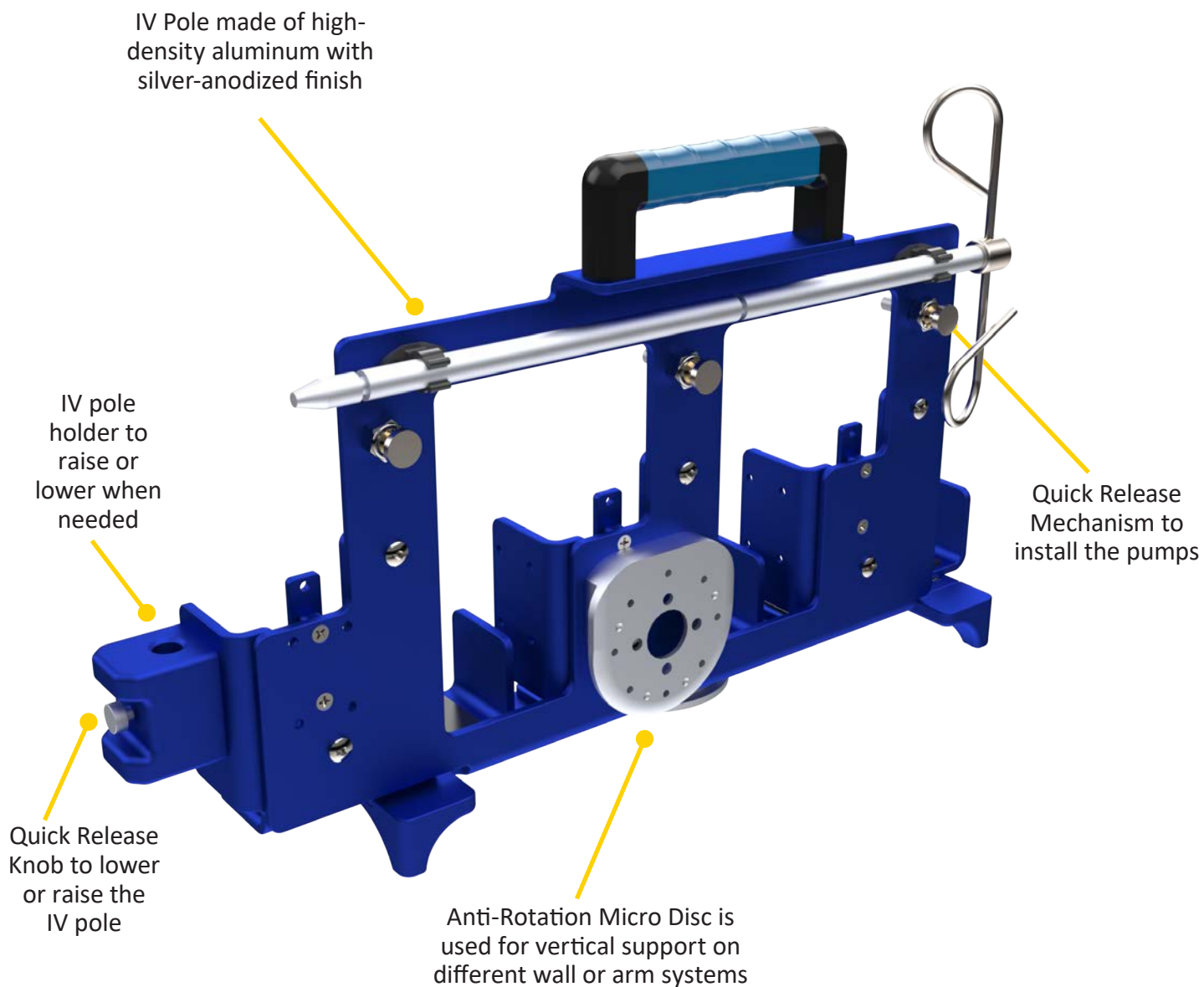

# INTRODUCTION

## SPECIFICATIONS

<b>Product Name</b>	Bracket Pro Serie® 121-FL
<b>Product Description</b>	Bracket mounting system to secure the Spectrum IQ Infusion Pumps on cots/stretchers and walls in emergency vehicles
<b>Compatibility of Medical Device*</b>	Baxter® Spectrum IQ Infusion Pump
<b>Environment of Usage</b>	EMS/CCT (Ground & Air) – Hospital/Clinic, Military
<b>Product Section Material</b>	<ul style="list-style-type: none"><li>• Main Assembly: Aluminum 6061-T6</li><li>• Bottom Micro Disc: Aluminum 6061-T6</li><li>• Anti-Rotation Micro Disc: Aluminum 6061-T6</li><li>• IV Pole: Aluminum 6061-T6</li><li>• IV Pole Hooks: Stainless Steel</li></ul>
<b>Product Finish</b>	<ul style="list-style-type: none"><li>• Main Assembly: Blue-Anodized Finish</li><li>• Bottom Micro Disc: Silver-Anodized Finish</li><li>• Anti-Rotation Micro Disc- Silver-Anodized Finish</li><li>• IV Pole: Silver-Anodized Finish</li><li>• IV Pole Hook: Silver-Anodized Finish</li></ul>
<b>Environmental Regulations</b>	Comply with RoSH 3
<b>Temperature of Usage</b>	- 35° C to 45° C
<b>Certification</b>	Designed to Comply with: <ul style="list-style-type: none"><li>• SAE J3043 (26 G)</li><li>• FAA, 14 CFR § 23 (applicable section)</li></ul>
<b>Installation</b>	Device Retained on Main Assembly with Quick Release Mechanism
<b>Attachment Options</b>	2 Locking Discs – Bottom Micro Disc – Anti-Rotation Micro Disc
<b>Transportation Compatibility System</b>	Compatible with Technimount's: <ul style="list-style-type: none"><li>• Wall Mount Systems</li><li>• Safety MD-Transporters</li><li>• Proplate with Micro Bases for Incubators</li></ul>
<b>Features</b>	<ul style="list-style-type: none"><li>• Robust Mounting Solution for EMS/CCT/ALS</li><li>• Air and Ground Compatibility</li><li>• Quick Release Mechanism to Easily Insert and Remove the Pumps</li><li>• Polyurethane Plastic Transport Handle</li></ul>
<b>Physical Overall Dimensions</b>	Width 20.26 in, Depth 4.56 in, Height 12.30 in.
<b>Weight</b>	6.82 lb
<b>Part Number</b>	<ul style="list-style-type: none"><li>• 1530-10-BXIQ-FL3 - Bracket Pro Serie 121-FL</li><li>• 120-20-UN - Mirco Base</li></ul>
<b>Other Models and Configuration Options</b>	Contact Technimount EMS for more information or for other options at <a href="mailto:customerservice@technimount.com">customerservice@technimount.com</a>

\* Product and medical equipment manufacturer names are trademarks™ or registered trademarks® of their respective holders. Technimount does not have a commercial relationship with these medical equipment manufacturers.

## NOTICE

The Bracket Pro Serie 121-FL is designed to comply with the essential requirements and other relevant provisions of the Directive 1999/5/EC and SAE J3043. Contact with Customer Service ([customerservice@technimount.com](mailto:customerservice@technimount.com)) for more information.

### **Technimount E.M.S. Holding Inc.**

C/O: Regulatory Affairs

3770 Jean Marchand Street, Suite 100-C

Quebec (QC) G2C 1Y6

Canada

T + 1 888.639.2758

F + 1 855.339.6351

[technimount.com](http://technimount.com)

[info@technimount.com](mailto:info@technimount.com)



## WARNING

The end user and administrator are responsible to validate regulations and standards for safety in their region, in order to comply with applicable safety regulations. Technimount is not responsible to inform the end user and/or the administrator of applicable legislation for safety in their area.

# SUMMARY OF SAFETY PRECAUTIONS

---

## WARNING/CAUTION/NOTE

Carefully read and strictly follow all Warnings and Cautions listed in this user guide. Servicing and maintenance should only be done by qualified personnel.

---

### WARNING

---

- ✓ Always hold the Bracket with both hands when you manipulate it.
- ✓ Operate the bracket only as described in this user guide.
- ✓ Do not modify the Bracket, or any components of Technimount systems. Modifying the product can cause unpredictable operation resulting in injury to the patient or operator.
- ✓ It is the responsibility of the operator of the Bracket or any of its options, to ensure equipment being used with the Technimount products meets the installation specifications. Injury may result if non-compatible products are used with Technimount System products.
- ✓ Do not attempt to operate, install or remove the equipment while mobile. Ensure that installation and removal of equipment is done while vehicle is immobilized.
- ✓ Verify that the bracket is inserted correctly into a mounting system and locked. If equipment is improperly installed and locked, it can cause the equipment to fall and cause injury to the patient or operator and/or damage to the medical equipment.
- ✓ Do not allow untrained staff to assist in the operation of the mounting system. Untrained technicians/staff can cause injury to the patient or themselves.
- ✓ Do not place additional equipment or items onto the Bracket or mounts other than approved Technimount Systems or components, as this could damage the product and may result in injury to the patient or operator.
- ✓ Operators must be able to safely lift the total weight of the Bracket System and Medical Device.
- ✓ Do not attach restraints to the Bracket frame. It may result in damage to the System and/or result in injury to the patient or operator.
- ✓ Always reposition the equipment with care, avoid any improper pushing or violent manipulation, as it may result in unbalanced equipment and may cause injury to the patient or operator and/or damage to the product.
- ✓ Improper maintenance can cause injury to patient or operator or damage to the product. Maintain the Bracket and Mounting Systems as described in this user guide. Use only Technimount approved parts and maintenance procedures. Using unapproved parts and procedures could cause unpredictable operation and/or injury and will void the product warranty.
- ✓ Failure to properly clean or dispose of corrosive products will increase the risk of premature damage and may cause injury to the patient or operator.
- ✓ Any installation on a surface, wall or on the structure of the vehicle or the aircraft has to be validated or inspected in order to ensure it maintains the integrity of the vehicle or the aircraft.

# SUMMARY OF SAFETY PRECAUTIONS

---

## WARNING/CAUTION/NOTE (CONTINUED)

---

### CAUTION

---

- ✓ Only certified technical personnel familiar with the Bracket installation and use should manipulate it. Always refer to Technimount's user guides for all instructions for installing and using any Technimount Mounting System.
- ✓ Inspect regularly all components on the equipment for any issue and loose screws, bolts and nuts.
- ✓ Never install the mount into or on other similar mounting systems or brackets without written confirmation by Technimount System as these different systems may be from other brands or models and may not be compatible with Technimount Systems.

### NOTE

- ✓ Some cleaning products are corrosive in nature and may cause damage to the product if used improperly. If such products are used to clean Technimount equipment, the equipment must be rinsed with clean water and thoroughly dried following the cleaning. Failure to properly rinse and dry the Mounting Systems will leave a corrosive residue on the surface, possibly causing premature corrosion of critical components.
- ✓ When ordering, it is important to identify on which mounting system you need to mount the bracket on as their are different systems for different EMS applications, e.g., EMS ground mounting systems.
- ✓ A maintenance program should be established for all Technimount equipment. Preventive maintenance may need to be performed more frequently, based on the level of use of the product. Close attention should be given to safety features (i.e.: screws, quick release mechanisms, and attachment points).
- ✓ Failure to use authorized parts, and lubricants, etc., could cause damage to the equipment and will void the warranty of the product.
- ✓ This user guide should be considered a permanent part of the Bracket, and should remain with the product even if the equipment is subsequently sold.
- ✓ Technimount continually seeks advancements in product design and quality. Therefore, while this user guide contains the most current product information available at the time of printing, there may contain minor differences between your mounting system and this user guide. If you have any questions, please contact Technimount Customer Service at +1.888.639.2758.

## REMOVING THE PACKAGING FOR INSTALLATION

1. Unpack boxes and check all items.
2. Ensure that all shipping and packaging materials have been properly removed from the product(s) prior to installation.
3. Identify all of the product components and hardware prior to starting the installation.
4. The Bracket System must work properly before being put into service.
5. Refer to the identification of components at the beginning of this user guide if needed.

## TOOLS REQUIRED FOR INSTALLATION

No tools are required for installation. If you have any questions regarding the installation, or need assistance, please contact our Technical Support team at [techsupport@technimount.com](mailto:techsupport@technimount.com)



# INSTALLATION GUIDE

## INSTALLATION OF THE BAXTER PUMPS ONTO THE BRACKET

1. Place the bracket on a stable surface for installation.

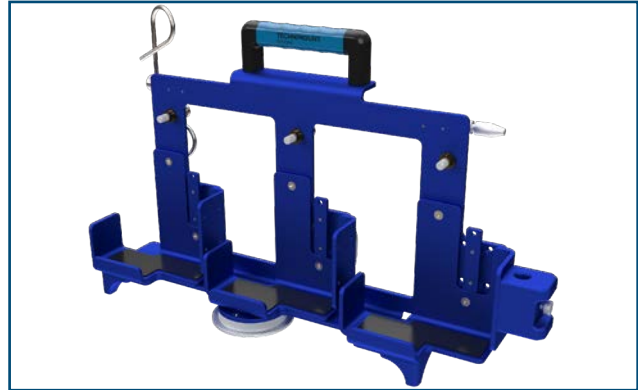

2. Before inserting the device, locate the locking block on the medical device.



3. Align the locking block with the support system on the bracket.

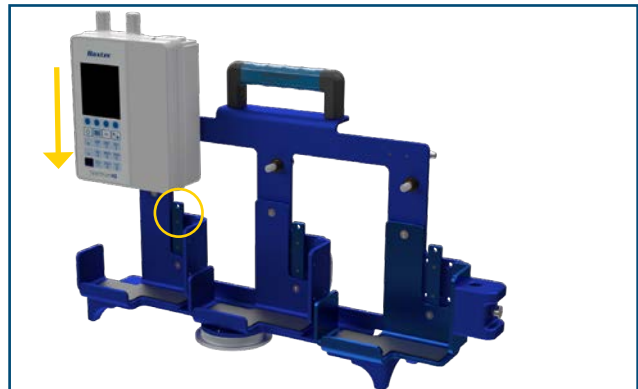

# INSTALLATION GUIDE

## INSTALLATION OF THE BAXTER PUMPS ONTO THE BRACKET (CONTINUED)

4. Pull on the Quick Release Mechanism and insert the medical device into the bracket.

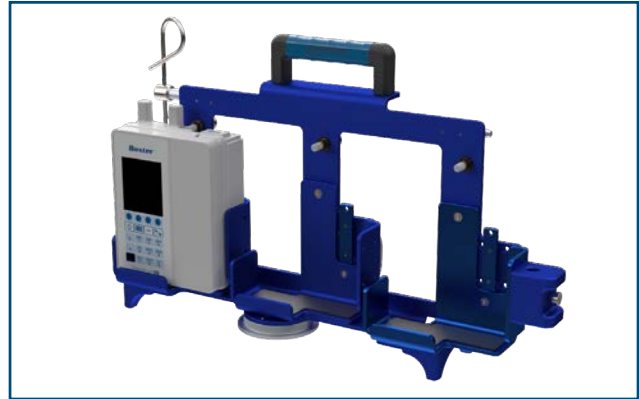

5. Proceed to install all pumps while following steps 1 to 4.



6. Once properly locked the Baxter pumps are ready for EMS transport.

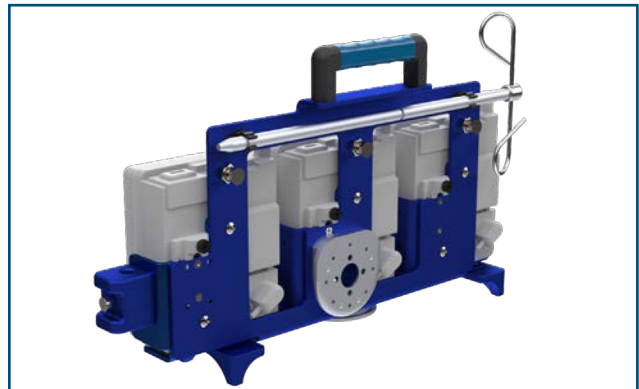

# INSTALLATION GUIDE

---

## INSTALLATION OF THE IV POLE

1. Insert the IV pole from the top of the IV pole holder.

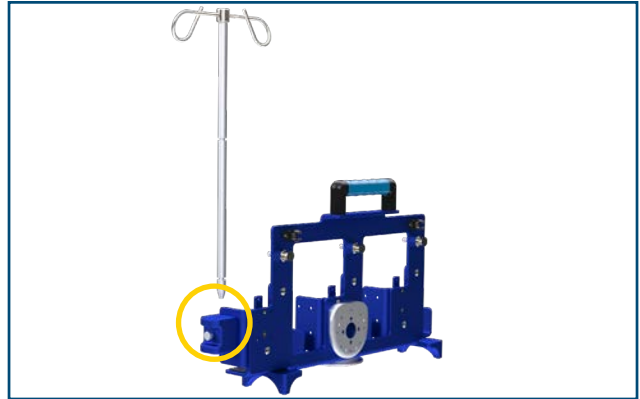

2. Slide in until you reach one of the grooves on the IV pole to hold into position.
3. The IV pole is now ready to be used with IV bags.

 **WARNING**

- ✓ Do not use the IV pole during EMS transport.



# PART NUMBERS

---

## KITS AND OTHER OPTIONS

DESCRIPTION	PART NUMBER
Part Number - Bracket Pro Serie 121-FL	1530-10-BXIQ-FL3
Part Number - Bracket Pro Serie 121-GR	1520-10-BXIQ-GR3
Wall Mount Only	553-20-AB-WA
Safety MD-Transporter	Refer to customer service for the right configuration for your stretcher

---

 **WARNING**

Do not modify any components of these system. Modifying the products can cause unpredictable operation resulting in injury to the patient or operator.

**NOTE**

Technimount reserves the right to change Part Numbers and Products without notice. Please refer to Customer Service to ensure product part number availability.

For any replacement parts or for repair, please contact Technical Support at [techsupport@technimount.com](mailto:techsupport@technimount.com)

## CLEANING THE BRACKET SYSTEM

### CLEANING PROCESS

---

#### WARNING

Follow your EMS service's protocol or medical device manufacturer's user guide for the recommended cleaning procedure of your medical devices. Cleaning procedure below does NOT provide recommendations for cleaning of the medical device. The following cleaning guidelines consider the Technimount mounting assemblies and components. Remove medical device from the bracket if thorough cleaning is needed.

The Bracket can be cleaned by using a pressure washer. The bracket may show some signs of oxidation or discoloration from continuous washing, however, degradation of the cot/stretchers performance or functionality will not be affected due to power washing if cleaning instructions are properly followed.

The material used to manufacture the Bracket is high-grade aluminum, it is very durable and resistant to corrosion, however high levels of sodium or a high concentration of sodium or acid may prematurely corrode the product. Always rinse with soft soap and water if exposed.

- ✓ Use of a power washer can accelerate removal of contaminants collected during the use of the product.
- ✓ Rinse with clean water.
- ✓ Towel dry all components.
- ✓ Allow all other components to air dry.
- ✓ Avoid over saturation and ensure that the product does not stay wet longer than the cleaner manufacturer's guidelines for proper disinfecting.

---

#### WARNING

- ✓ When cleaning, always use appropriate personal protection equipment (PPE) based on established protocols (e.g., gloves, eyewear, etc.).

---

#### CAUTION

- ✓ Do not steam clean or use ultrasonic cleaners on the system or any of its components.
- ✓ Do not immerse the metal parts/components in water.
- ✓ Maximum water temperature should not exceed 180°F/82°C.
- ✓ Maximum water pressure should not exceed 1500 psi/103.5 BAR . If a pressure washer is being used to clean the unit, the pressure nozzle must be kept a minimum of 24 inches (61 cm) from the unit.

### CLEANING SOLUTIONS

Phenolic type or quaternary type disinfectants can be used (excluding Virex® TB). Iodophor type disinfectants, Peracetic Acid, Chlorine, and especially Hydrogen Peroxide are not recommended for use because staining and corrosion may result.

Suggested cleaners for the Bracket:

- ✓ Quaternary Cleaners (active ingredient - ammonium chloride)
- ✓ Phenolic Cleaners (active ingredient - o-phenyl phenol)
- ✓ Chlorinated Bleach Solution (3.25% - less than 1-part bleach to 100 parts water)

[Return To Table of Contents](#)

## CLEANING THE BRACKET SYSTEM (CONTINUED)

### CLEANING SOLUTIONS CONTINUED

---

#### WARNING

- ✓ Some cleaning products are corrosive in nature and may cause damage to the product if used improperly.
- ✓ If the products described are used to clean the equipment, the Bracket and components must be rinsed with clean water and thoroughly dried following cleaning. Failure to properly rinse and dry the system will leave a corrosive residue on the surface of the product, possibly causing premature corrosion of critical components.

### REMOVAL OF IODINE COMPOUNDS

Use a solution of 1/4 Tablespoon of Sodium Thiosulfate in 1 pint / .5 litre of warm water to clean the stained area. Clean as soon as possible after staining occurs. If stains are not immediately removed, allow solution to soak or stand on the surface. Thoroughly rinse surfaces with clean water and allow to air dry before returning unit to service.

---

#### WARNING

- ✓ Failure to properly clean contaminated parts or components will increase the risk of exposure to blood borne pathogens and may cause injury to the patient or the operator.

## PREVENTIVE MAINTENANCE

A preventive and regular maintenance program should be established for all Technimount equipment. Preventive maintenance may be required more frequently based on the usage level of the product. The Bracket requires regular preventative maintenance. Establish and follow a preventive maintenance schedule and keep records of preventive maintenance activities (see maintenance form in this user guide).

---

#### CAUTION

- ✓ Close attention should be given to safety features including, but not limited to locking mechanisms and Discs.
- ✓ Improper maintenance can cause injury or damage to the product. Maintain the product as described in this user guide.

### LUBRICATION

The Bracket System has been designed to operate without the need for lubrication. If you have questions, please contact Technical Support at [techsupport@technimount.com](mailto:techsupport@technimount.com).

---

#### CAUTION

- ✓ Failure to use authorized parts, lubricants, etc. could cause damage to the cot/stretchers and will void the warranty of the product.

# MAINTENANCE GUIDE

## INSPECTION PROCESS AND SCHEDULE

### MAINTENANCE PROGRAM

The following inspection routine and schedule is intended as a general guide for preventive maintenance of the Bracket. Factors such as weather, environment, geographical location, and individual usage will necessitate different maintenance. If you are unsure as to how to perform these maintenance inspections or at what interval to perform these inspections, please contact your Technical Support Team at [techsupport@technimount.com](mailto:techsupport@technimount.com). Check each routine and replace damaged or worn out parts if necessary.

Follow timetable below for maintenance (either in months (M) or hours (H)), in accordance with your Service's current maintenance practices and protocols.

<u>ITEM</u>	<u>ROUTINE</u>	<u>1 M</u> <u>OR</u> <u>2 H</u>	<u>3 M</u> <u>OR</u> <u>6 H</u>	<u>6 M</u> <u>OR</u> <u>12 H</u>	<u>12 M</u> <u>OR</u> <u>24 H</u>
Bracket	<ul style="list-style-type: none"> <li>✓ Inspect Bracket                             <ul style="list-style-type: none"> <li>▪ Inspect the screws</li> <li>▪ Ensure it is working properly and there are no particles, obstacles, or debris</li> <li>▪ Inspect back screws</li> </ul> </li> <li>✓ Verify Discs                             <ul style="list-style-type: none"> <li>▪ Verify that there is no damage or dirt on the discs and there are no loose screws</li> <li>▪ The discs can be easily inserted into and removed from Micro Base</li> </ul> </li> <li>✓ Do a visual inspection for the Bracket to ensure there is no damage or chemical attack</li> <li>✓ Inspect the Quick Release Mechanism to ensure there is no damage and it locks properly</li> </ul>	X			

# MAINTENANCE GUIDE

---

## INSPECTION AND MAINTENANCE RECORD

<u>PREVENTIVE MAINTENANCE PERFORMED</u>	<u>BY</u>	<u>DATE</u>	<u>TIME</u>





# MAINTENANCE GUIDE

---

## REPLACEMENT PARTS

The parts and accessories listed are all currently available for purchase. Some of the parts identified on the assembly drawing parts in this user guide may not be individually available for purchase. Please call Technimount Customer Service : +1.888.639.2758 or at [customerservice@technimount.com](mailto:customerservice@technimount.com) for availability and pricing.

<u>DESCRIPTION</u>	<u>PART NUMBER</u>
IV Pole	TCM-052-037
Acetal Feet	TCM-032-082

## WARRANTY POLICY

This statement constitutes TECHNIMOUNT's entire warranty policy with regards to the TECHNIMOUNT Products.

TECHNIMOUNT MAKES NO OTHER WARRANTY OR REPRESENTATION NEITHER EXPRESSED NOR IMPLIED, EXCEPT AS SET FORTH HEREIN. THERE IS NO WARRANTY OF MERCHANTABILITY AND THERE ARE NO WARRANTIES OF FITNESS FOR ANY PARTICULAR PURPOSE. IN NO EVENT SHALL TECHNIMOUNT BE LIABLE HEREUNDER FOR INCIDENTAL OR CONSEQUENTIAL DAMAGES ARISING FROM OR IN ANY MANNER RELATED TO SALES OR USE OF ANY SUCH EQUIPMENT.

TECHNIMOUNT E.M.S. Holding Inc. (TECHNIMOUNT) guarantees to the original "Purchaser" of the "Hardware" with which this "Limited Warranty" is included that the Hardware will be free from "Defects" in workmanship and materials under normal use for a "Warranty Period", one (1) year from the date that the Hardware was first purchased by the Purchaser. During the Warranty Period, the Hardware will be repaired or replaced according to the "Limited Warranty" without charge to the Purchaser for either parts or labor. The parts may be repaired or replaced with either new or refurbished parts. The product may be replaced for a new or refurbished product. For this Limited Warranty "refurbished" means parts and products, which have been returned to factory specifications. If the Hardware is repaired or replaced within the Warranty Period, the greater of the remaining warranty period will apply or three (3) months from the date of repair/replacement. If the Hardware is repaired or replaced after the Warranty Period has expired, the Warranty Period for the repair or replacement will expire three (3) months after the date of repair or replacement.

## LIMITED RESPONSIBILITY AND WARRANTY

The Limited Warranty does not apply to normal wear that should result from normal use. It does not apply when the Hardware or any component is opened, disassembled, or repaired by someone not authorized by TECHNIMOUNT and does not cover repair or replacement of any Hardware or part thereof damaged by neglect, misuse, moisture, liquids, exposure to heat, accidents, abuse, and non-compliance with the instructions for installation and use provided with the Hardware. The Limited Warranty does not cover physical damage to the surface of the Hardware, and the decision to repair, replace or refuse the coverage is final and its sole discretion of TECHNIMOUNT, and is made without any compensation or obligation from TECHNIMOUNT.

The hardware, or product defined as a mounting or bracket system for clipping and attaching medical equipment is specifically designed to fill this requirement. Any other use will void the warranty and TECHNIMOUNT will not be held liable on any claim if the product is modified or adapted for use.

Technimount products are intended to retain a medical device in place in the case of a single crash impact. A Technimount product must NOT be used again if it was involved in a crash. The product MUST be replaced. If the Purchaser uses a Technimount product following a crash, it is at the Purchaser's own risk and Technimount will not be held liable.

## INTERNATIONAL WARRANTY CLAUSE

This warranty reflects Canadian domestic policy. Warranty outside Canada may vary by country. Please contact TECHNIMOUNT Customer Service for more information.

## RETURN POLICY

Mounting systems and bracket systems for portable medical devices may be returned up to 60 days of receipt if:

- The product is not what was originally ordered
- The product does not meet specifications with TECHNIMOUNT's technical sheets according to the customer
- The product is not compatible with the equipment on which it was to be installed

For any manufacturing defect, refer to the conditions of the Warranty Policy.

### PRIOR TO 30 DAYS

- Product must be undamaged and in its original packaging
- The product return request must be provided in writing and it must be approved by TECHNIMOUNT prior to returning the product
- Returns will not be approved on a modified or damaged item
- Charges may apply if damaged or missing item
- Customer is responsible for a 10% restocking fee

### PRIOR TO 45 DAYS

- Product must be unused, undamaged and in its original packaging
- The product return request must be provided in writing and it must be approved by TECHNIMOUNT prior to returning the product
- Returns will not be approved on modified or damaged item
- Charges may apply if damaged or missing items
- Customer is responsible for a 25% restocking fee

### PRIOR TO 60 DAYS

- Product must be unused, undamaged and in its original packaging
- The product return request must be provided in writing and it must be approved by TECHNIMOUNT prior to returning the product
- Returns will not be approved on a modified or damaged item
- Charges may apply if damaged or missing items
- Customer is responsible for a 30% restocking fee

## RETURN AUTHORIZATION

TECHNIMOUNT's customer service department is responsible for approving any merchandise return and will provide a Return Merchandise Authorization (RMA) number to be printed on any returned merchandise. TECHNIMOUNT reserves the right to charge shipping and restocking fees on returned items. SPECIAL, MODIFIED, OR DISCONTINUED ITEMS NOT SUBJECT TO RETURN.

## DAMAGED MERCHANDISE

ICC Regulations require that claims for damaged merchandise must be made with the carrier within fifteen (15) days of receiving merchandise. DO NOT ACCEPT DAMAGED SHIPMENTS UNLESS SUCH DAMAGE IS NOTED ON THE DELIVERY RECEIPT AT THE TIME OF RECEIPT. Upon prompt notification, TECHNIMOUNT will file a freight claim with the appropriate carrier for damages incurred. Claim will be limited in amount to the actual replacement cost. In the event that this information is not received by TECHNIMOUNT within the fifteen (15) day period following the delivery of the merchandise, or the damage was not noted on the delivery receipt at the time of receipt, the customer will be responsible for payment of the original invoice in full.

Note: Claims for any short or broken shipment must be made within thirty (30) days of invoice.

## CLAIM PROCESS

Please follow the claim procedure below to return a defective product:

Fill in the RMA form online at <https://www.technimount.com/service-support/service-support-overview/>

### REQUIRED INFORMATION

- Serial number
- Invoice number
- Identification of the issue
- Upload the pictures of the issue
- Submit the form

A confirmation of the receipt of the claim will be sent to you within 2 business days. If you have not received a confirmation Email by then, please contact [techsupport@technimount.com](mailto:techsupport@technimount.com).

If the RMA request is approved, TECHNIMOUNT will provide you with an RMA number for your claim. We will also include instructions for the replacement of your product. No product return will be accepted without the RMA number labeled on the outside of the box being returned.

### FINDINGS AND CONCLUSION

- If following an investigation, we find that our product is defective, TECHNIMOUNT will take corrective actions and close the claim
- If following an investigation, we find that our product is NOT defective (misuse or abuse of the product) the product will not be covered by the warranty. Details of our findings and conclusions will be provided to you.

## QUESTIONS ABOUT OUR POLICY

If you have any questions regarding our return policy, please contact our Customer Service department at [customerservice@technimount.com](mailto:customerservice@technimount.com).

# SAE CERTIFICATION

---





# SAFETY AND FLEXIBILITY WHERE IT MATTERS MOST

TECHNIMOUNT E.M.S. HOLDING INC.  
3770 Jean Marchand Street, Suite 100-C  
Quebec (QC) G2C 1Y6  
Canada  
T + 1 888.639.2758  
F + 1 855.339.6351  
[technimount.com](http://technimount.com)  
[info@technimount.com](mailto:info@technimount.com)

© 2021 Technimount E.M.S. Holding Inc. - All Rights Reserved  
Printed in Canada



**TECHNIMOUNT**  
EMS™