



TECHNIMOUNT
EMS™

SAFETY ARM SYSTEM™ 500

USER GUIDE



COPYRIGHT

Copyright 2022 Technimount E.M.S. Holding Inc. (Technimount), an affiliated company of Technologies CGC Inc. All Rights Reserved. No part of this publication may be reproduced, transmitted, transcribed, stored in a retrieval system, or translated into any language in any form or by any means without the written permission of Technimount or its affiliate companies.

Trademark Attributions:

Technimount System™ and Technimount EMS™ are registered trademarks of Technologies CGC Inc.

Safety Arm System™ is a Trademark of Technologies CGC Inc.

Stryker® stretcher models and numbers are registered trademarks of Stryker.

In order to ensure continuous improvements to our products and services, we invite you to communicate your comments to our Customer Service Department at customerservice@technimount.com.

CONTACT INFORMATION

CORPORATE HEADQUARTERS

TECHIMOUNT E.M.S. HOLDING INC.
3770 Jean Marchand Street, Suite 100-C
Quebec (QC) G2C 1Y6
Canada

info@technimount.com

www.technimount.com

T + 1 581.700.6613

TF + 1 888.639.2758

NOTE:

For any issues with your Technimount product, its components, or for any technical questions during the installation or maintenance, please send an Email to techsupport@technimount.com

Please have the serial number of your Technimount product available (as shown on picture below) when calling Technimount Customer Service or Technical Support. Include the serial number in all written communications.

SERIAL NUMBER LOCATION

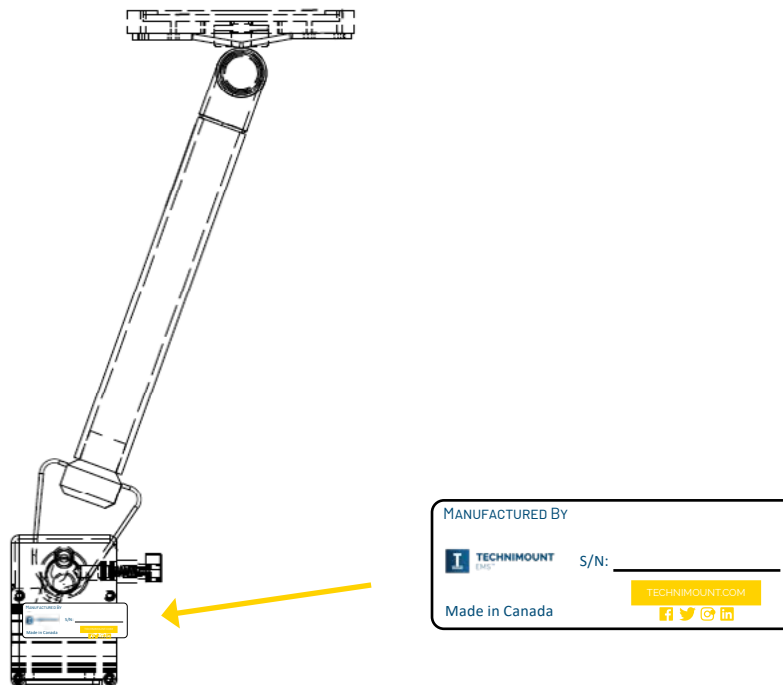

[Return To Table of Contents](#)

TABLE OF CONTENTS

COPYRIGHT	2
CONTACT INFORMATION.....	3
INTRODUCTION	6
PRODUCT DESCRIPTION	6
INTENDED USE OF THE PRODUCT	6
SYMBOLS AND DEFINITIONS	7
WARNING / CAUTION / NOTE.....	8
IDENTIFICATION OF COMPONENTS.....	9
<i>LOCK PIN</i>	9
<i>SAFETY PIN</i>	9
<i>CLAMP BLOCK</i>	10
<i>SAFETY ARM</i>	10
<i>HARDWARE KIT FOR THE SAFETY ARM</i>	11
PRODUCT OPTIONS AVAILABLE	11
INSTALLATION RELATED TO THE STRYKER POWERLOAD STRETCHER.....	11
TECHNICAL SPECIFICATIONS.....	12
NOTICE	14
PRODUCT INFORMATION	15
PRODUCT ILLUSTRATION WITH OTHER EQUIPMENT ON STRETCHER	15
<i>INSTALLATION OVERVIEW</i>	16
SUMMARY OF SAFETY PRECAUTIONS	17
WARNING/CAUTION/NOTE	17
INSTALLATION GUIDE	20
REMOVING PACKAGING FOR INSTALLATION	20
TOOLS REQUIRED FOR INSTALLATION.....	20
COT/STRETCHER ORIENTATION DIAGRAM	21
PREPARING THE COT/STRETCHER FOR INSTALLATION	22
<i>REMOVING THE IV POLE OR CHANGING THE SIDE OF THE IV POLE</i>	22
SAFETY ARM SYSTEM INSTALLATION.....	25
<i>POSITION ON THE COT/STRETCHER</i>	25
<i>PATIENT RIGHT AND LEFT INSTALLATION</i>	25
<i>POSITION ON THE COT/STRETCHER (CONTINUED)</i>	26
<i>PATIENT RIGHT INSTALLATION</i>	26
<i>INSTALLING THE CLAMP BLOCK (PATIENT RIGHT)</i>	27
<i>PREPARING THE IV PRO ADAPTER PLATE</i>	31
<i>INSTALLING THE MICRO BASE ON THE IV PRO ADAPTER PLATE</i>	32
<i>INSTALLING THE IV PRO ADAPTER</i>	33
<i>INSTALLING THE IV POLE AND HOLDER ONTO THE IV PRO ADAPTER</i>	36
<i>INSTALLING THE SAFETY ARM INTO THE CLAMP BLOCK</i>	38
<i>INSTALLING THE STANDARD SURFACE BASE ONTO THE SAFETY ARM SYSTEM UPPER PLATE</i>	39
OPERATION CAUTION AND WARNING	41
OPERATION GUIDE	42
GENERAL OPERATING GUIDELINES.....	42
<i>RECOMMENDED LIFTING TECHNIQUES</i>	42
<i>RECOMMENDED HANDLING POSITIONS</i>	43
OPERATING THE SAFETY ARM SYSTEM	44
<i>LOWERING THE SAFETY ARM</i>	45

TABLE OF CONTENTS

<i>RAISING THE SAFETY ARM</i>	46
<i>REMOVING THE SAFETY ARM</i>	47
SAFETY ARM SYSTEM OPTIONS	49
STRYKER POWER-PRO OPTIONS.....	49
STRYKER MX-PRO OPTIONS.....	49
MAINTENANCE GUIDE.....	50
CLEANING THE SAFETY ARM SYSTEM	50
<i>CLEANING PROCESS</i>	50
<i>CLEANING SOLUTIONS</i>	50
<i>REMOVAL OF IODINE COMPOUNDS</i>	51
PREVENTIVE MAINTENANCE.....	51
<i>LUBRICATION</i>	51
INSPECTION PROCESS AND SCHEDULE.....	52
<i>PREVENTIVE MAINTENANCE PROGRAM</i>	52
INSPECTION AND MAINTENANCE RECORD.....	53
TRAINING RECORD.....	54
REPLACEMENT PARTS.....	55
WARRANTY	56
WARRANTY POLICY	56
LIMITED RESPONSIBILITY AND WARRANTY.....	56
INTERNATIONAL WARRANTY CLAUSE	56
RETURN POLICY	57
RETURN POLICY.....	57
<i>PRIOR TO 30 DAYS</i>	57
<i>PRIOR TO 45 DAYS</i>	57
<i>PRIOR TO 60 DAYS</i>	57
RETURN AUTHORIZATION.....	57
DAMAGED MERCHANDISE.....	58
CLAIM PROCESS	58
<i>REQUIRED INFORMATION</i>	58
<i>FINDINGS AND CONCLUSION</i>	58
QUESTIONS ABOUT OUR POLICY.....	58
SAE CERTIFICATION	59

INTRODUCTION

This user guide is designed to assist you with the installation, operation and maintenance of the Technimount Safety Arm System 500.

PRODUCT DESCRIPTION

The Technimount Safety Arm System 500 is a mounting solution for the stretcher that consists of a platform, mounted on a top-down movable arm, installed with a clamp block on the stretcher frame. It is designed to support and transport portable medical devices with a maximum weight of 30 lbs. in EMS and Critical Care Transport. The medical device can be removed and stored safely when not in use. When the arm is used in emergency vehicles with a cot/stretcher, it has two positions, upper locked position for transport and the lower position for loading/unloading of the patient on the stretcher. The red safety pin must be pulled to lower or raise the arm.

The Safety Arm System is equipped with a safety locking mechanism to secure the position of the arm during transport. When not in use, the arm can be lowered for loading and unloading of the patient. The arm is also equipped with a side locking pin with a finger ring handle in order to secure the arm into the clamp block attached to the stretcher. In case of emergencies, the side locking pin can be removed in less than 5 seconds, by releasing or pulling back the fixed safety locking mechanism. Once removed, raise the Safety Arm to disengage it from the clamp block.

Once combined with the surface base mounting system (Bracket Pro Serie®) it allows the medical crew to see and use the unit during transport as well as during patient loading and unloading.

INTENDED USE OF THE PRODUCT

The Safety Arm System 500 is a secure mounting system for medical devices, designed to be installed on a stretcher (Stryker Stretchers MX-PRO and Power-PRO models). The mount is intended to support and transport medical equipment during a medical intervention of a traumatized, an ambulatory or non-ambulatory patient (including infants, children and adults).

The upper position (or locked position) is designed to incorporate the use of the medical device while transporting the patient and performing normal tasks by medical personnel. The lower position (or unlocked position) is designed to assist with loading or unloading of the patient onto/from the stretcher, and it is not designed to be used during the movement or transport of the stretcher.



Once the arm is in the upper position (or locked position), it facilitates the safe transport of associated medical equipment (i.e. defibrillator and/or pumps) in emergency vehicles. The use of the Safety Arm System 500 was developed to be used on an ambulance stretcher and intended for front-line responders who have received the training necessary to operate the System in the field. The expected service life of the Safety Arm System is 5 years, or more, depending upon use.

The Safety Arm System is intended for transport purposes only. It is not intended for more than one unit nor any additional equipment attached to the arm.

Please read this user guide thoroughly before using this equipment. To ensure the safe operation of this equipment, it is recommended to train staff prior to use.

[Return To Table of Contents](#)



SYMBOLS AND DEFINITIONS

SYMBOL	DESCRIPTION
	Caution, special attention is required. Consult accompanying documents
	Safe working load symbol and Load balance symbol
	Pinch Point

INTRODUCTION

WARNING / CAUTION / NOTE

The word warning, caution, or note carry special meaning and should be carefully reviewed.

SYMBOL	DESCRIPTION
	<p>WARNING</p> <p>Alerts the reader about a situation which, if not avoided, could result in death or serious injury. It may also describe potential serious adverse reactions and safety hazards.</p>
	<p>CAUTION</p> <p>Alerts the reader of a potentially hazardous situation, which, if not avoided, may result in minor or moderate injury to the user or patient or damage to the equipment or other property. This includes special care necessary for the safe and effective use of the device to avoid damage that may occur as a result of use or misuse.</p>
<p>NOTE</p>	<p>Provides special information about the product.</p>

IDENTIFICATION OF COMPONENTS

LOCK PIN

The Lock Pin is made of stainless steel with a finger ring. It is used to lock the Safety Arm System inside the clamp block. It goes through the clamp block and the bottom of the arm, locking the arm inside the clamp block.



LOCK PIN WITH FINGER RING

SAFETY PIN

The fixed safety pin is identified by the red round handle mechanism used for locking the arm in the upper position.

- a) Side Lock Pin Aperture
- b) Safety Pin with red handle

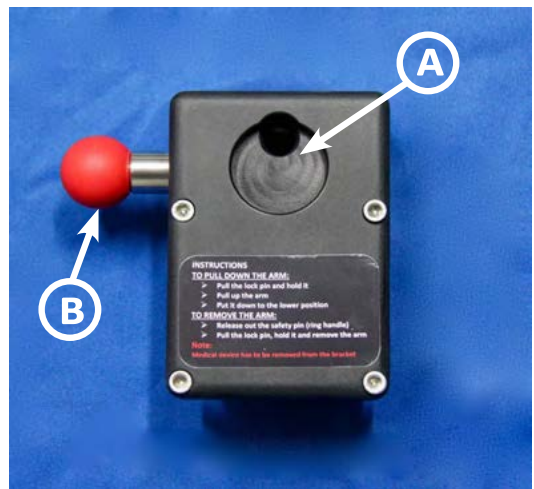

CLAMP BLOCK WITH SAFETY PIN

INTRODUCTION

IDENTIFICATION OF COMPONENTS (CONTINUED)

CLAMP BLOCK

The clamp block is the two (2) part metal system attached on one side of the stretcher frame, in order to support and insert the arm. The two sections are attached with four (4) stainless steel hexagon socket pan head screws; as shown in picture on the right.



CLAMP BLOCK BEFORE ASSEMBLY



CLAMP BLOCK AFTER ASSEMBLY

SAFETY ARM

The base mount (upper plate) is welded onto the safety arm as shown in picture on the right. The yellow safety arm goes into the clamp block as shown in picture on the right.



**SAFETY ARM BASE MOUNT (UPPER PLATE)
AND B) HARDWARE FOR INSTALLATION OF THE
BASE TO THE PLATE**



YELLOW SAFETY ARM

INTRODUCTION

HARDWARE KIT FOR THE SAFETY ARM

The hardware (stainless steel screws, nuts and caps) are provided for the installation of the Standard Surface Base on the upper plate.

1. 2 stainless steel screws 10-32 x 1-3/4" Philips (star)
2. 2 stainless steel screws 10-32 x 1-1/4" Philips (star)
3. 4 stainless steel hexagonal nuts 10-32 x 3/8"
4. 2 stainless steel hexagonal Caps 10-32

PRODUCT OPTIONS AVAILABLE

1. The yellow color is the standard color for the Safety Arm System.
2. Straight and Angled arm models for left and right side of the stretcher are available for additional configuration options.
3. To install the IV Pole on the same side of the Safety Arm Stretcher, an IV Pro Adapter plate is required to support it. Contact Customer Service for more information, customerservice@technimount.com

INSTALLATION RELATED TO THE STRYKER POWERLOAD STRETCHER

- ✓ The spacer block is the shim installed under the "V" bracket on the cot/stretcher frame when a power load system is installed with the cot/stretcher. This bracket is NOT a Technimount part.

[Return To Table of Contents](#)

INTRODUCTION

TECHNICAL SPECIFICATIONS

Product Name	Safety Arm System™ 500
Product Description	Securely transports portable medical devices directly on Stryker stretchers
Cot/Stretcher Compatibility	<ul style="list-style-type: none">• Stryker® Power-Pro XT, model 6500-6506• Stryker® Performance-Pro XT, model 6085-6086• Stryker® MX-PRO R3
Environment of Usage	EMS (Ground & Flight) – Hospital/Clinic, Military
Product Section Material	<ul style="list-style-type: none">• Main Assembly: Aluminum 6061-T6• Clamp Block: Aluminum 6061-T6
Product Finish	<ul style="list-style-type: none">• Main Assembly: Yellow Powder Coat• Clamp Block: Hard Black-Anodized Finish
Environmental Regulations	Complying with RoHS 3
Maximum Load Capacity	30 lb (13.61 kg)
Temperature of Usage	-31° F to 113°F (-35° C to 45° C)
Certification	Designed to Comply with: <ul style="list-style-type: none">• SAE J3043 (26 G)
Installation	Mounting System Retained on Stretcher with Clamp Block, Lock Pin and Red Handle Safety Pin.
Transportation Compatibility Systems	Compatible with Technimount's: <ul style="list-style-type: none">• Standard Surface Base• Bracket Pro Serie® Product Line with a Standard Bottom Disc• IV Pro Adapter with or without Knee Gatch (Patient Left, Patient Right)
Features	<ul style="list-style-type: none">• Top-down Movable Arm for Patient Loading/Unloading on Both Sides• Dual Locking Mechanism (Lock Pin and Safety Pin)• Left and Right Angled Arm and Straight Arm Models Available for additional configuration options on patient left and patient right side
Overall Physical Dimensions	Total height with Clamp Block - 22.6 in (57.4 cm) Overall length with Clamp Block - 21.6 in (59.93 cm) Clearance Between Stretcher Mattress and Safety Arm System with Standard Surface Base: <ul style="list-style-type: none">• Cot Mattress Up - 17.25 in (43.8 cm)• Cot Mattress Down - 10 in (25.4 cm)• Space from Stretcher Frame to Under Base Plate in Lower Position<ul style="list-style-type: none">• With Tubbing - 9.4 in (23.8 cm)• After the Base Plate - 12 in (35.5 cm)

[Return To Table of Contents](#)

TECHNICAL SPECIFICATIONS CONTINUED

Weight	<ul style="list-style-type: none">• 3.35 lb (1.52 kg) - Safety Arm System without Standard Surface Base• 2.92 lb (1.32 kg) - Clamp Block• 5.57 lb (2.53 kg) - Safety Arm System including Hardware
Part Numbers	<ul style="list-style-type: none">• 400-20-UN - Safety Arm (Right Side Arm Only)• 400-20-UN-ANG - Safety Arm (Right Side Angular Arm Only)• 400-20-UN-LFS - Safety Arm (Left Side Arm Only)• 400-20-UN-LFS-ANG - Safety Arm (Left Side Angular Arm Only)• 500-10-PFXT - Clamp Block (Stryker Power-Pro XT Right Side)• 500-10-PFXT-LFS - Clamp Block (Stryker Power-Pro XT Left Side)• 530-10-MXPR - Clamp Block (Stryker MX-PRO Right Side)• 530-10-MXPR-LFS - Clamp Block (Stryker MX-PRO Left Side)
Other Models and Configuration Options	Contact Technimount EMS for more information or for other options at customerservice@technimount.com

INTRODUCTION

NOTICE

The Safety Arm System is designed to comply with SAE J3043 safety standards. Please contact Technimount Customer Service Department at (customerservice@technimount.com) for more information.

Technimount E.M.S. Holding Inc.

Regulatory Affairs
3770, Jean Marchand Street, Suite 100-C
Quebec City (QC) G2C 1Y6
Canada
T + 1 581.700.6613
TF + 1 888.639.2758
technimount.com
legal@technimount.com

WARNING

The end users and administrators are responsible to validate regulations and standards for safety in their region, in order to comply with applicable safety regulations. Technimount is not responsible to inform the end user and/or the administrator of applicable legislation for safety in their area.

PRODUCT INFORMATION

PRODUCT ILLUSTRATION WITH OTHER EQUIPMENT ON STRETCHER

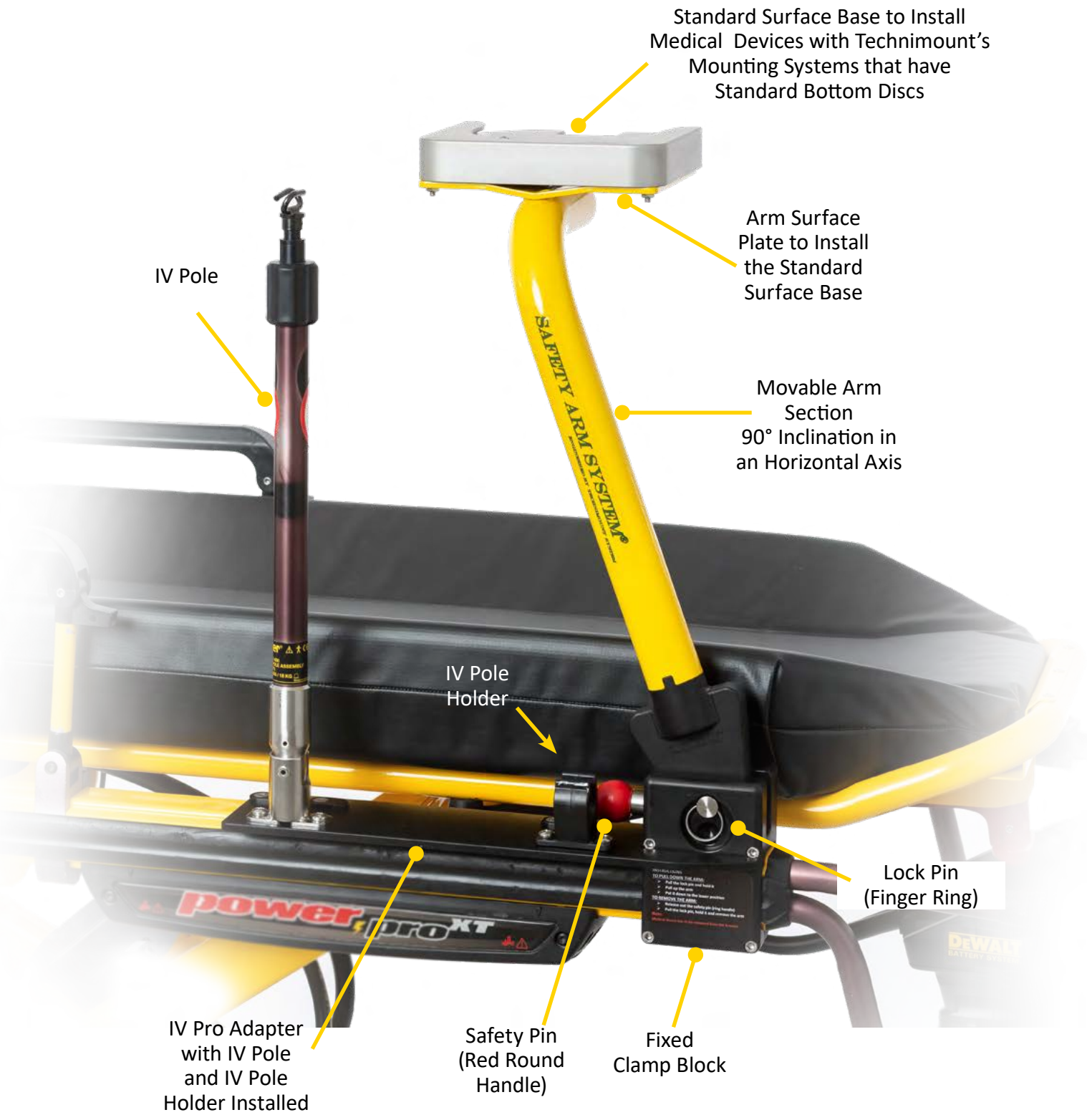

Standard Surface Base to Install Medical Devices with Technimount's Mounting Systems that have Standard Bottom Discs

Arm Surface Plate to Install the Standard Surface Base

Movable Arm Section 90° Inclination in an Horizontal Axis

IV Pole

IV Pole Holder

IV Pro Adapter with IV Pole and IV Pole Holder Installed

Safety Pin (Red Round Handle)

Fixed Clamp Block

Lock Pin (Finger Ring)

[Return To Table of Contents](#)

PRODUCT ILLUSTRATION (CONTINUED)

INSTALLATION OVERVIEW

Upper Position

Locked Position for
Transportation

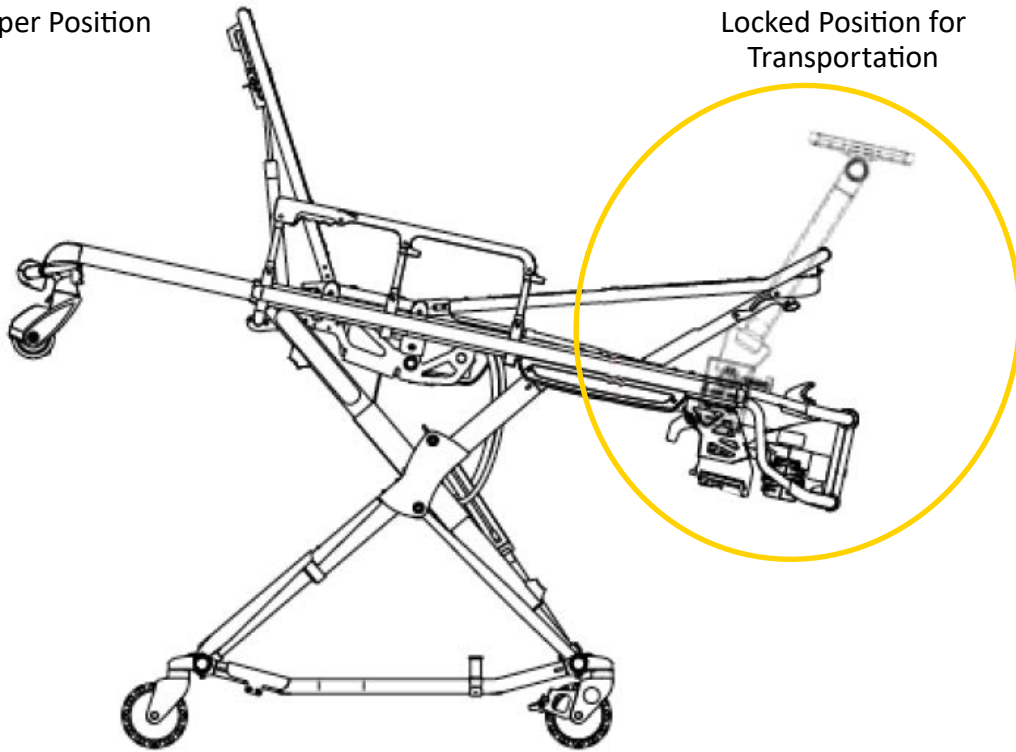

SAFETY ARM SYSTEM INSTALLED ON COT

SUMMARY OF SAFETY PRECAUTIONS

WARNING/CAUTION/NOTE

Carefully read and strictly follow all Warnings and Cautions listed in this manual. Servicing and maintenance should only be done by qualified personnel.

WARNING

- ✓ Always hold the arm when you manipulate it.
- ✓ Always pull and hold the Safety Pin (red handle) until it reaches the final upper position (**locked**) or lower position (**unlocked**). Failure to do so can cause damage to the equipment.
- ✓ To avoid injury, hands should be clear of the black clamp block and arm pivot while loading and unloading the medical equipment or whenever changing height position of the arm with two or more operators.
- ✓ Improper usage of the Safety Arm System can cause serious injury to the patient or operator. Operate the arm only as described in this user guide.
- ✓ Do not modify the arm or any components of the system. Modifying the product can cause unpredictable operation resulting in injury to the patient or operator.
- ✓ It is the responsibility of the operator of the cot/stretchers to ensure that the Safety Arm System being used with Technimount products meets the installation specifications. Injury may result if non-compatible products are used with Technimount products.
- ✓ Do not attempt to operate the arm when it is loaded into a vehicle or in a very tight or narrow space.
- ✓ Failure to install the side Lock Pin (finger ring) can cause the arm to fall and may cause injury to the operator and may damage the product. Always secure the arm with the safety pin. Install and use the safety pin as described in this user guide.
- ✓ To avoid any injury, verify that the side safety pin has been pulled all the way through the clamp block before removing the arm from the cot/stretchers or lowering the arm to the unlocked position.
- ✓ Verify that both pins (Safety Pin and Lock Pin) are always pushed into the holes of the clamp block and the arm base is in the locked position. Regardless of how the arm is loaded or unloaded with a medical device, injury to the patient or operator and/or damage to the arm may occur.
- ✓ Practice changing arm positions (Transportation (Locked)/Loading & Unloading (Unlocked)) until operation of the product is fully understood. Improper use may cause injury to the operator.
- ✓ Always hold the arm securely near the bend (top of the arm) when changing positions from locked to unlocked. Failure to do so, can cause damage to the product and/or the cot/stretchers.
- ✓ Do not allow untrained staff to assist in the operation of the arm system. Untrained technicians/staff can cause injury to the patient or themselves.
- ✓ Do not sit on the tubular pole (arm), damage to the product could occur, and may result in injury to the patient or operator.
- ✓ Grasping the arm improperly can cause injury. Keep hands, fingers and feet away from moving parts. To avoid injury, use extreme caution when placing your hands near the tubular base (arm and clamp block) while raising or lowering the arm.
- ✓ Operators must be able to safely lift the total weight of the Safety Arm System (arm and medical device), and any items attached to the arm.
- ✓ Never use the arm when installed on the cot/stretchers in the lower or unlocked position, to open the rear vehicle door, or pull the cot/stretchers with the arm.
- ✓ Do not attempt to load the arm with the medical device in the lower or unlocked position. Loading a medical device onto the arm must be in the upper and locked position, if not installed properly, the medical device on the Standard Surface Base may cause injury to the patient or operator and/or damage to the product.

[Return To Table of Contents](#)

SUMMARY OF SAFETY PRECAUTIONS

WARNING/CAUTION NOTE (CONTINUED)

WARNING (CONTINUED)

- ✓ Do not attach restraints to the base tubular frame, the Standard Surface Base, or any other place of the arm system. It may result in damage to the arm and/or result in injury to the patient or operator.
- ✓ Do not place any additional equipment or objects on the arm, other than the approved Technimount device bracket for medical devices.
- ✓ Always reposition the arm with care. Avoid any improper pushing, violent manipulation and impacts to surroundings as it may result in an unbalanced cot/stretchers and may cause injury to the patient or operator and/or damage to the product.
- ✓ To avoid the risk of patient injury or equipment damage, ensure that you properly mount and secure the defibrillator platform (bracket) to the arm's Standard Surface Base.
- ✓ To avoid the risk of patient injury or equipment damage, you must make sure that the disc attached to the bracket under the medical device is properly locked into the Standard Surface Base prior to repositioning the arm.
- ✓ If you want to remove the arm from the system, make sure you remove the medical device from the Standard Surface Base prior the operation, failure of removing it may result in damage to the product, or cause injury to the operator.
- ✓ Improper maintenance can cause injury or damage to the product. Maintain the Safety Arm System as described in this user guide. Use only Technimount approved parts and maintenance procedures. Using unapproved parts and procedures could cause unpredictable operation and/or injury and will void the product warranty.
- ✓ Failure to properly clean or dispose of corrosive products will increase the risk of premature damage and may cause injury to the patient or operator.
- ✓ Ensure proper hand placement on a high position on the tubular frame (pole). Hands should be clear of clamp block while loading and unloading the arm or whenever changing height position of the arm system with two or more operators.
- ✓ Do not adjust or change the position of the arm while you are walking or working with the cot/stretchers. Stay with the patient and control the arm at all times.

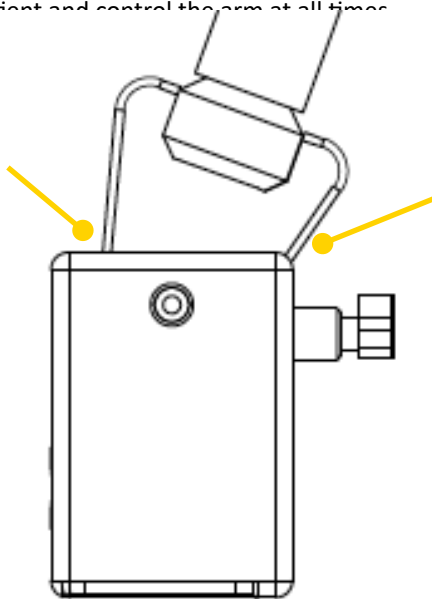

SIDE VIEW OF THE CLAMP BLOCK AND ARM PIVOT

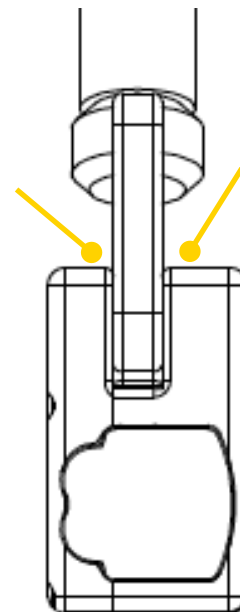

SIDE VIEW OF THE CLAMP BLOCK AND ARM PIVOT

[Return To Table of Contents](#)

SUMMARY OF SAFETY PRECAUTIONS

WARNING/CAUTION"NOTE (CONTINUED)

CAUTION

- ✓ Certified technical personnel familiar with the cot/stretchers specifications should complete the installation of the clamp block. Refer to the cot/stretchers manufacturer's manual before installing the Safety Arm System and ensure that the installation of the Safety Arm System does not damage or interfere with the use of the cot/stretchers.
- ✓ Inspect regularly the clamp block and Standard Surface Base for any issue and loose screws, bolts and nuts.
- ✓ Do not use a Safety Arm System that is damaged or was subject to a vehicle collision, car crash or any road incident.

NOTE

- ✓ Some cleaning products are corrosive in nature and may cause damage to the product if used improperly. If such products are used to clean Technimount equipment, the equipment must be rinsed with clean water and thoroughly dried following the cleaning. Failure to properly rinse and dry the Arm will leave a corrosive residue on the surface of the cot/stretchers, possibly causing premature corrosion of critical components.
- ✓ Installation of the Safety Arm System was designed to be placed on either side of the stretchers with the use of the right or the left Safety Arm System (patient right or left). When ordering, it is important to identify which side the Safety Arm is to be located. The Safety Arm System cannot be reversed as the clamp block has been designed for a specific side.
- ✓ A preventive maintenance program should be established for all Technimount equipment. Preventive maintenance may need to be performed more frequently, based on the level of use of the product. Close attention should be given to safety features (i.e.: safety pins, and attachment points).
- ✓ Failure to use authorized parts, and lubricants, etc., could cause damage to the arm and will void the warranty of the product.
- ✓ This user guide should be considered a permanent part of the Safety Arm System and should remain with the product even if the arm is subsequently sold.
- ✓ Always manipulate the arm at the lower position of the cot/stretchers, as much possible; high lever may unbalance the cot/stretchers with violent movement or unpredictable motion.

Technimount continually seeks advancements in product design and quality. Therefore, while this manual contains the most current product information available at the time of printing, there may be minor discrepancies between your arm system and this user guide. If you have any questions, please contact Technimount Customer Service or Technical Support at +1.581.700.6613.

[Return To Table of Contents](#)

INSTALLATION GUIDE

REMOVING PACKAGING FOR INSTALLATION

1. Unpack boxes and check all items for proper operation.
2. Ensure that all shipping and packaging materials have been properly removed from the product(s) prior to installation.
3. Identify all of the product components and hardware prior to starting the installation.
4. Some hardware or parts provided might not be applicable to the model of your cot/stretchers.
5. The Safety Arm System must work properly before it is put into service.
6. Refer to the identification of components at the beginning of this user guide if needed.

NOTE

- ✓ Loose items or debris on the cot/stretchers can interfere with the operation of the Safety Arm System and cot/stretchers. Keep the cot/stretchers and the floor clear.

TOOLS REQUIRED FOR INSTALLATION

Below are the basic tools required for installation. Other tools may also be needed. If you have any questions regarding the installation, or need assistance, please contact our Technical Support team at techsupport@technimount.com



ALLEN KEY 3/16 IN



S2-T27 STAR BIT SCREWDRIVER



RUBBER HAMMER

NOTE

- ✓ Electrical tools are not recommended for screwing into the cot/stretchers frame, as there is a potential risk of damage to the threads.
- ✓ During the installation process, Technimount recommends the use of Blue Loctite 2400 to avoid premature loosening of screws during normal use. Put a few drops of Blue Loctite on each screw prior to installation.



The Loctite™ Brand shown above is provided as a suggestion only. Technimount System and its subsidiaries are not related to, nor does it commercially endorse this brand.

[Return To Table of Contents](#)

INSTALLATION GUIDE

COT/STRETCHER ORIENTATION DIAGRAM

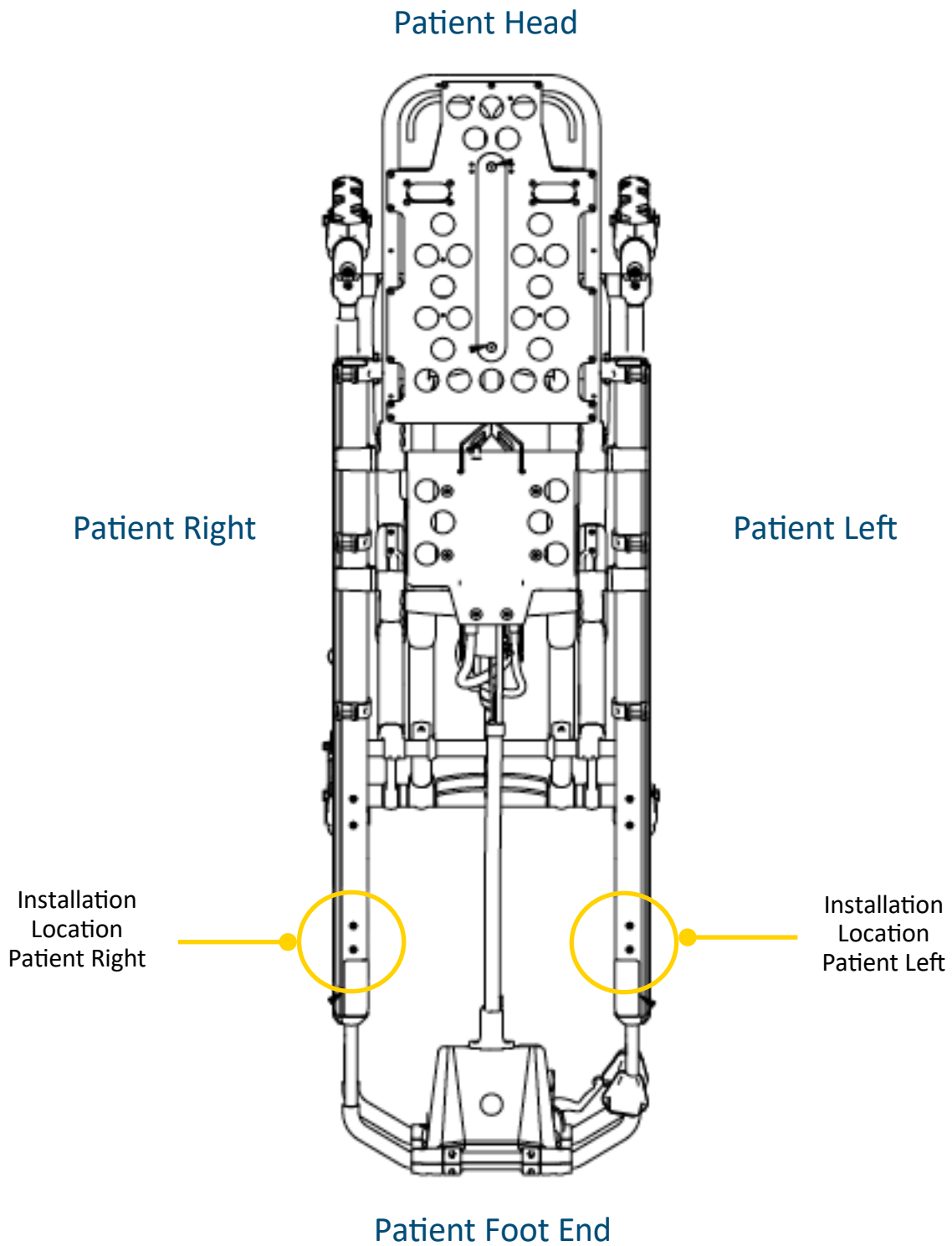

[Return To Table of Contents](#)

PREPARING THE COT/STRETCHER FOR INSTALLATION

REMOVING THE IV POLE OR CHANGING THE SIDE OF THE IV POLE

NOTE

- ✓ If the cot/stretchers has an IV pole located on the side you want to install the Safety Arm System, you will need to remove the IV Pole.
- ✓ To keep the IV pole on the same side as the cot/stretchers, you will need to install a Technimount IV Pro Adapter (Refer to Replacement Parts Table).
- ✓ Locating the IV pole on the same side as the Safety Arm System does not interfere with the installation or the operation of the arm.
- ✓ You will need to validate the location of the installation before removing the IV pole hardware.
- ✓ Technimount has two (2) different Safety Arm models. The standard 400 model for Ferno cots or the 500 model for Stryker cots.
- ✓ The installation procedure provided in this user guide is for **Patient Right** installation. The procedure is the same for both right and left sides.
- ✓ You might not have to perform these steps if you do not have an IV pole installed.
- ✓ Please refer to the cot/stretchers manufacturer's manual for more information about installation/re-installation of the IV pole.

INSTALLATION GUIDE

PREPARING THE COT/STRETCHER FOR INSTALLATION (CONTINUED)

REMOVING THE IV POLE OR CHANGING SIDE OF IV POLE (CONTINUED)

1. To access screws that hold the IV pole and the holder, lift the IV pole to its upper position.



2. Remove all four (4) screws.
3. Remove IV Pole and holder.



4. Replace all four (4) screws.



[Return To Table of Contents](#)

INSTALLATION GUIDE

PREPARING THE COT/STRETCHER FOR INSTALLATION (CONTINUED)

REMOVING THE IV POLE OR CHANGING SIDE OF IV POLE (CONTINUED)

5. The IV pole can be installed on the other side of the cot/stretcher, utilizing the same bracket/holder.



6. If the IV Pole is not needed, store for later use.



INSTALLATION GUIDE

SAFETY ARM SYSTEM INSTALLATION

CAUTION

- ✓ It is the responsibility of the Safety Arm System operator to ensure that the system being used on the cot/stretcher meets the installation specifications. Injury may result if a non-compatible cot/stretcher is used.

NOTE

- ✓ The Safety Arm System Installation instructions are intended for cots/stretchers that you will use with or without a Power-Load system.
- ✓ Adjustment of the clamp block assembly may be required in order to compensate for any variation in the cot/stretcher frame dimension depending on the cot/stretcher manufacturer and model number.

POSITION ON THE COT/STRETCHER

Patient Right and Left Installation

NOTE

- ✓ When ordering the Safety Arm System, it is important to specify on which side the arm will be installed on, as the System cannot be installed on the opposite side. There is a right or left clamp block designed for each side.
- ✓ The Arm cannot be switched from one side to the other. You need to order a system according to the side that is needed.
- ✓ The location for the installation of the clamp block is the same on patient right or left sides.

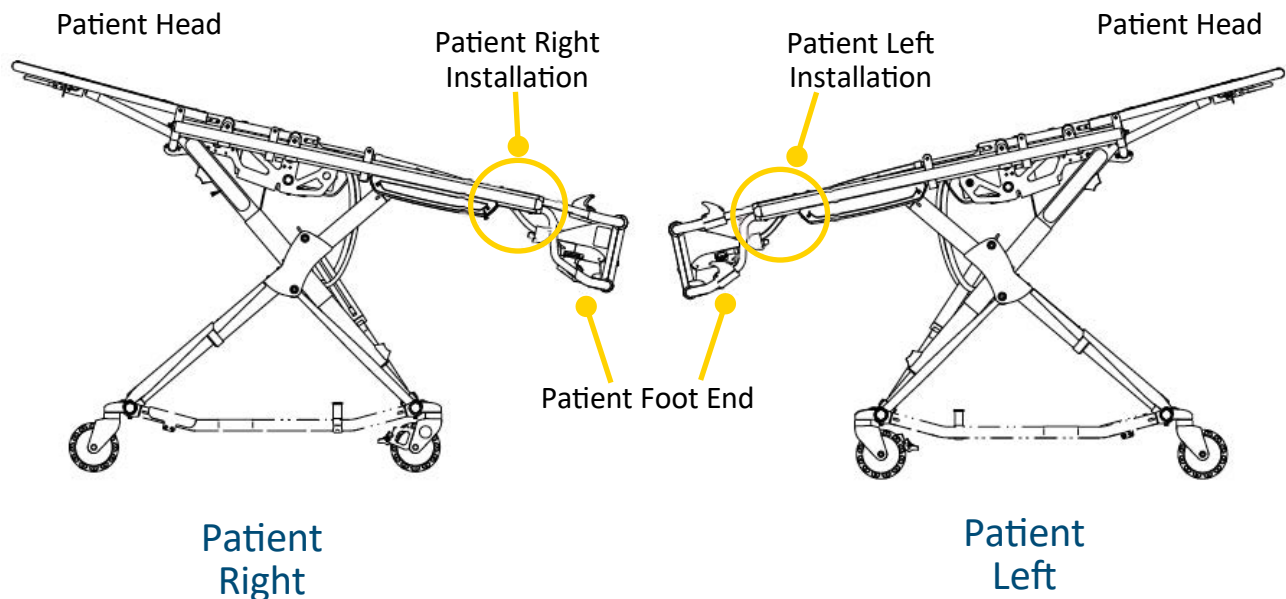

MODEL 500 - INSTALLATION POSITION ON PATIENT RIGHT AND LEFT SIDES

[Return To Table of Contents](#)

INSTALLATION GUIDE

SAFETY ARM SYSTEM INSTALLATION (CONTINUED)

POSITION ON THE COT/STRETCHER (CONTINUED)

Patient Right Installation

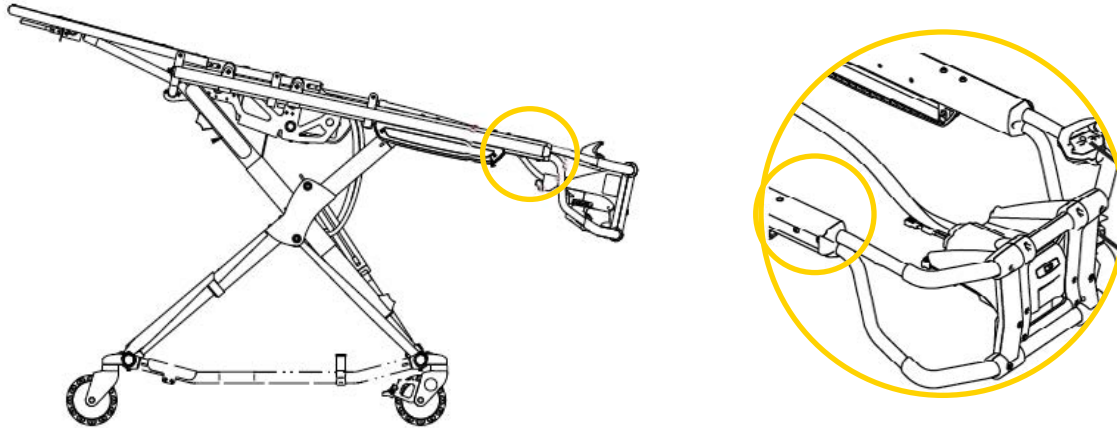

POSITION OF THE CLAMP BLOCK ON THE SIDE RAIL FRAME - PATIENT RIGHT

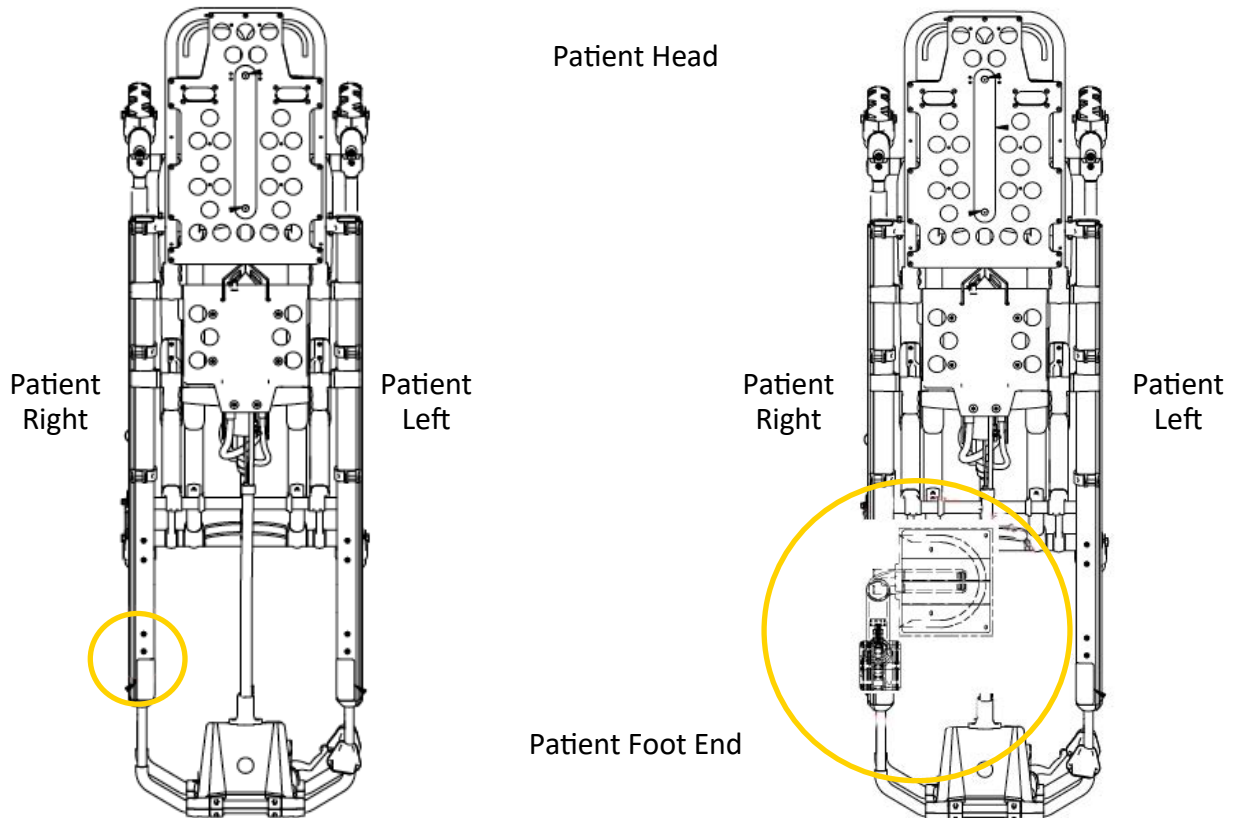

POSITION OF SAFETY ARM SYSTEM - PATIENT RIGHT

PATIENT RIGHT SAFETY ARM SYSTEM INSTALLED AND IN UPPER POSITION (LOCKED)

[Return To Table of Contents](#)

INSTALLATION GUIDE

SAFETY ARM SYSTEM INSTALLATION (CONTINUED)

INSTALLING THE CLAMP BLOCK (PATIENT RIGHT)

NOTE

- ✓ During the installation process, Technimount recommends the use of Blue Loctite 2400 to avoid premature loosening of screws during normal use. Put a few drops of Blue Loctite on each screw prior to installation.



The Loctite™ Brand shown above is provided as a suggestion only. Technimount System and its subsidiaries are not related to, nor does it commercially endorse this brand.

1. Identify the location on the cot/stretchers where you need to install the clamp block.



2. Locate the two (2) screws that are attached under the front section of the frame.



[Return To Table of Contents](#)

INSTALLATION GUIDE

SAFETY ARM SYSTEM INSTALLATION (CONTINUED)

INSTALLING THE CLAMP BLOCK (PATIENT RIGHT) (CONTINUED)

3. Unscrew the 2 bolts with 3/16 in Allen key (or Star bite S2-T27) and set aside to be used in next step.
4. Remove the spacer, and store it, as it won't be used in the installation. Clamp Block Replaces this part.
5. Loosen the 2 screws that are on the opposite side of the stretcher to facilitate the installation of the clamp block.



6. Unscrew the four (4) stainless steel hexagon socket open head screws of the clamp block with the 3/16 in Allen key.



7. Use the part with the fixed red handle to place vertically on the inside of the cot/stretcher frame.

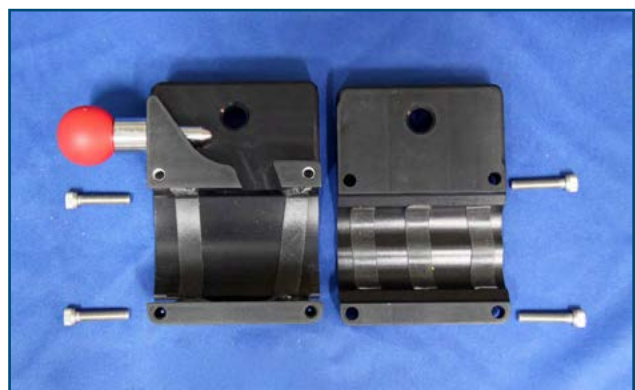

INSTALLATION GUIDE

SAFETY ARM SYSTEM INSTALLATION (CONTINUED)

INSTALLING THE CLAMP BLOCK (PATIENT RIGHT) (CONTINUED)

8. Position the clamp block under the black plate of the frame.



9. Align with the two (2) screw holes.



10. Add a couple of drops of blue Loctite 2400 to the screws before installation.
11. Tighten screws, while alternating screwheads.
12. Tighten the screws located on the opposite side of the stretcher.



[Return To Table of Contents](#)

INSTALLATION GUIDE

SAFETY ARM SYSTEM INSTALLATION (CONTINUED)

INSTALLING THE CLAMP BLOCK (PATIENT RIGHT) (CONTINUED)

13. Position the other side of the clamp block. A tiny yellow line of the frame should remain visible.
14. Add a couple of drops of blue Loctite 2400 to the screws before installation.

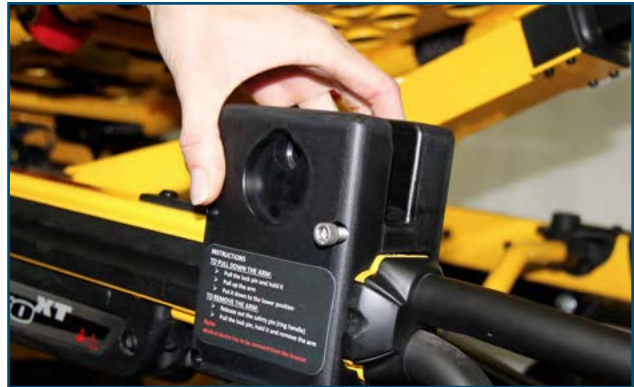

15. Tighten all four (4) stainless steel hexagon socket pan head screws, while alternating with all four (4) screws.



16. Once the clamp block is properly installed, you are ready to install the Safety Arm into the clamp block.



SAFETY ARM SYSTEM INSTALLATION (CONTINUED)

PREPARING THE IV PRO ADAPTER PLATE

NOTE

- ✓ The following 4 steps are for the installation of the IV Pro Adapter plate. If not applicable, continue to Installing the Safety Arm System Into the Clamp Block (Page 38).

1. Install the 2 blocks provided with Safety MD Transporter onto the IV Pro Adapter plate.

NOTE:

- ✓ Ensure to install the short block on the side of the IV Pro Adapter plate with pointed end.

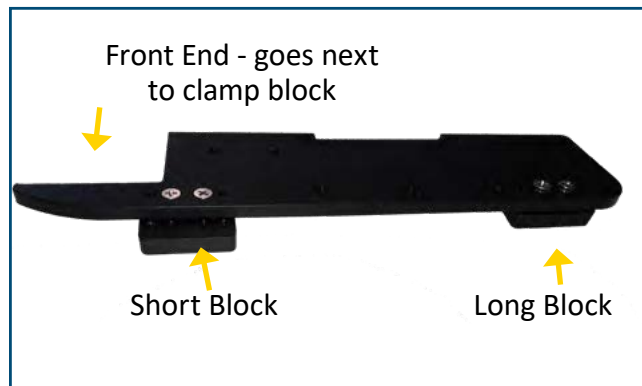

2. Using screwdriver with a star bit, tighten all 4 screws (2 on each block).
3. Insert screws from the bottom of the IV Pro Adapter plate.

NOTE

- ✓ Installation of the blocks is performed underneath of the plate, in order to have the blocks on the upper side once installed.

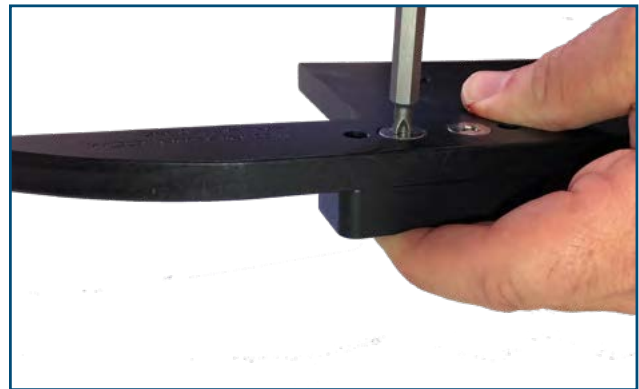

4. IV Pro Adapter plate with the 2 blocks installed.



[Return To Table of Contents](#)

INSTALLATION GUIDE

SAFETY ARM SYSTEM INSTALLATION (CONTINUED)

INSTALLING THE MICRO BASE ON THE IV PRO ADAPTER PLATE

NOTE

✓ The following 4 steps are for the installation of the Micro Base onto the IV Pro Adapter plate. If not applicable, proceed to the following page (Page 33).

1. Five (5) screws are provided to install the Micro Base onto the IV Pro Adapter plate.



2. Align with the five (5) screw holes.



3. Add a couple of drops of blue Loctite to the screws before installation.
4. Tighten screws, while alternating screwheads.



[Return To Table of Contents](#)

SAFETY ARM SYSTEM INSTALLATION (CONTINUED)

INSTALLING THE IV PRO ADAPTER

NOTE

- ✓ During the installation process, Technimount System recommends the use of Loctite 2400 (Blue) to avoid premature loosening of screws during normal use.

1. Identify the location on the cot/stretcher where you need to install the IV Pro Adapter.

NOTE

- ✓ Make sure the IV Pro Adapter will correspond to the feature of the stretcher/cot with or without the knee gatch. The knee gatch feature will require two (2) recesses on the IV Pro Adapter plate, the one without knee gatch will have only one (1) long recess to obtain the proper fit on the stretcher/cot.



2. Pull and hold the Safety Pin (red round handle) while putting a pair of pliers to hold the pin open.

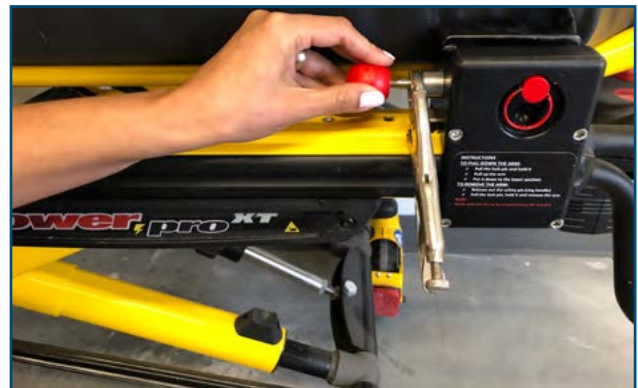

INSTALLATION GUIDE

SAFETY ARM SYSTEM INSTALLATION (CONTINUED)

INSTALLING THE IV PRO ADAPTER (CONTINUED)

- When pliers are secured in place on the screw to hold the Safety Pin open, turn the red round handle counter clockwise, to unscrew and remove the red round handle.

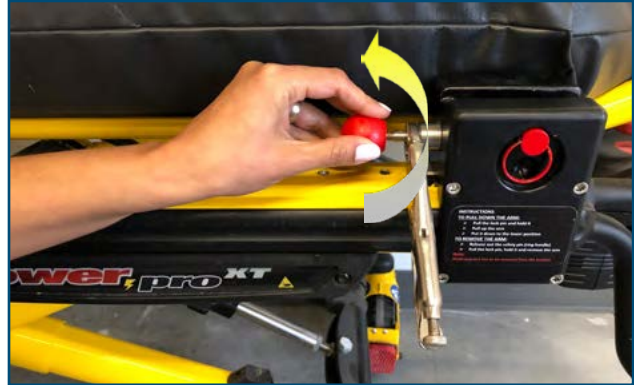

- Remove the red round handle.

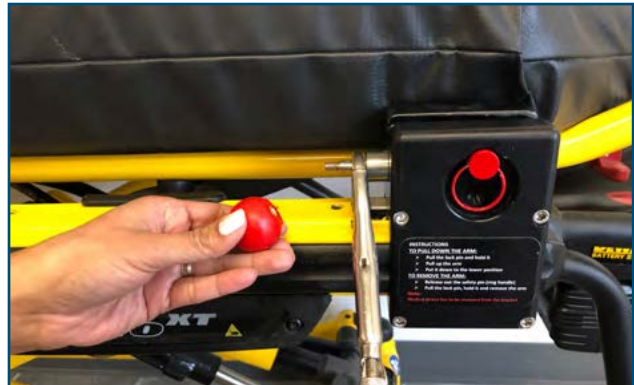

- Locate all 4 screw holes on the stretcher frame.



SAFETY ARM SYSTEM INSTALLATION (CONTINUED)

INSTALLING THE IV PRO ADAPTER (CONTINUED)

NOTE

✓ The Micro Base shown in the following images does not impact the installation of the IV Pro Adapter plate

6. Align IV Pro Adapter plate with the 4 screw holes on the cot/stretcher
7. Put a few drops of blue Loctite on each screw.
8. Tighten all four (4) screws while alternating screwheads



9. Push pin from the inside of the clamp block outward and place a pair of pliers on the screw to hold open while you replace the red round handle.
10. Put on a pair of gloves in order to put some blue Loctite onto the safety pin screw.



WARNING

✓ Use safety glasses to protect the eyes. Use impermeable gloves and protective clothing as necessary to prevent skin contact.

11. Put a few drops of blue Loctite onto the screw before replacing the red round handle. This will prevent premature loosening of the screws during normal use.
12. Replace the red round handle while turning clockwise.



[Return To Table of Contents](#)

INSTALLATION GUIDE

SAFETY ARM SYSTEM INSTALLATION (CONTINUED)

INSTALLING THE IV PRO ADAPTER (CONTINUED)

13. Screw in tightly.



INSTALLING THE IV POLE AND HOLDER ONTO THE IV PRO ADAPTER

1. Locate the 2 blocks on either side of the IV Pro Adapter plate.

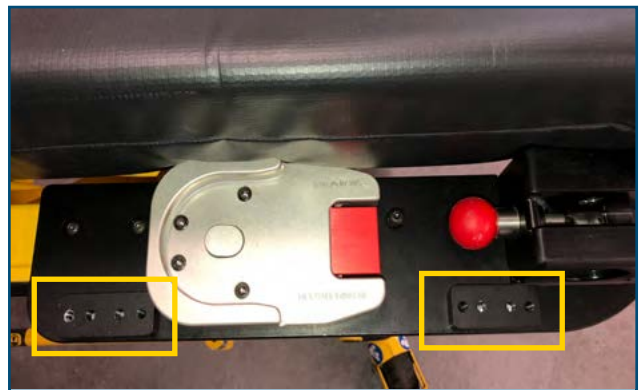

2. Install the IV Pro Holder onto the block located near the Clamp Block.
3. Align with the two (2) screw holes.
4. Tighten both screws.



[Return To Table of Contents](#)

INSTALLATION GUIDE

SAFETY ARM SYSTEM INSTALLATION (CONTINUED)

INSTALLING THE IV POLE AND HOLDER ONTO THE IV PRO ADAPTER (CONTINUED)

5. Install the IV pole onto the IV Pro Adapter plate second block
6. Align with the two (2) screw holes.
7. Use the same screws provided with the IV Pole or similar screws provided, with same threads and length.
8. Tighten both screws.



9. When not in use, lower the IV pole and clip it into its holder.



[Return To Table of Contents](#)

SAFETY ARM SYSTEM INSTALLATION (CONTINUED)

INSTALLING THE SAFETY ARM INTO THE CLAMP BLOCK

1. Pull the fixed safety pin (red round handle) outward and adjust the arm to align the hole of the clamp block with the hole of the triangle at the base of the arm.



2. Push the Lock pin in until the finger ring is flat against the wall of the clamp.



3. The fixed safety pin (red round handle) and side lock pin (finger ring) should be fully inserted and locked when the arm is in the upper position (Locked).

WARNING

Failure to insert the side safety pin properly may result in injury to the patient or operator and/or damage to the cot/stretchers and/or the medical equipment.



INSTALLATION GUIDE

SAFETY ARM SYSTEM INSTALLATION (CONTINUED)

INSTALLING THE STANDARD SURFACE BASE ONTO THE SAFETY ARM SYSTEM UPPER PLATE

1. Ensure that the Safety Arm System is in the upper position (Locked).



2. Identify the desired location of the surface base on the upper plate.



3. Keep in mind the position of the “red” quick release mechanism for easy access to the medical device. The base can be installed in 2 different positions, according to desired configuration and protocol. Can be turned in the other direction, (180°).

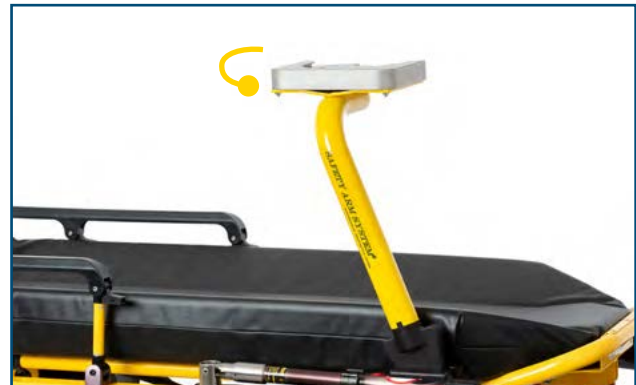

[Return To Table of Contents](#)

SAFETY ARM SYSTEM INSTALLATION (CONTINUED)

INSTALLING THE STANDARD SURFACE BASE ONTO THE SAFETY ARM SYSTEM UPPER PLATE (CONTINUED)

NOTE:

You will use only four (4) holes on the upper plate.

1. Place the Standard Surface Base on top of the arm's surface plate and use the hardware provided to secure the base to the plate.
2. The round headed hexagon nuts (2) should be placed on the same side of the arm to cover the longer of the 4 bolts.
3. Use the (2) longer bolts to secure the back of the Standard Surface Base on the opposite side of the red quick release button.

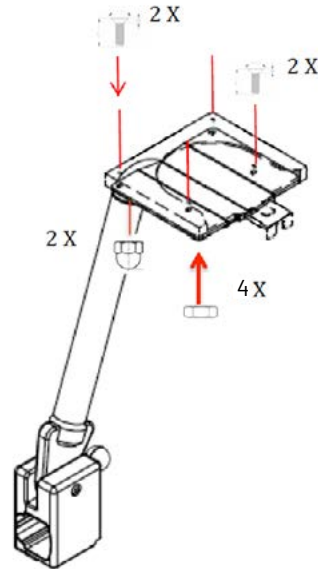

FIGURE 17. PATIENT RIGHT SAFETY ARM SYSTEM INSTALLATION OF THE STANDARD SURFACE BASE ON UPPER PLATE

4. Align the two (2) stainless steel screws 10-32 in x 1-3/4 in with the two (2) pre-drilled holes in the back of the upper plate and the Standard Surface Base. Use Loctite™ on the four (4) bolts to avoid potential loosening of the screws, due to vibration.
5. Repeat the same step with the other two (2) stainless steel screws 10-32 in x 1-1/4 in at the front or the middle of the base, and tighten them with the Philips screwdriver.
6. Tighten all four (4) screws of the Standard Surface Base at the front, and at the back with the Philips screwdriver and the mechanical wrench SAE 3/8 in.



[Return To Table of Contents](#)

SAFETY ARM SYSTEM INSTALLATION (CONTINUED)

INSTALLING THE STANDARD SURFACE BASE ONTO THE SAFETY ARM SYSTEM UPPER PLATE (CONTINUED)

CAUTION

- ✓ Before operating the arm, clear any obstacles that may interfere and cause injury to the operator, patient or that may damage the medical equipment.
- ✓ Always keep a safe distance from the foot end of the cot/stretcher, clear of any obstacles while operating the arm. Maintain a minimum distance of at least 24 inches (2 feet) while operating.

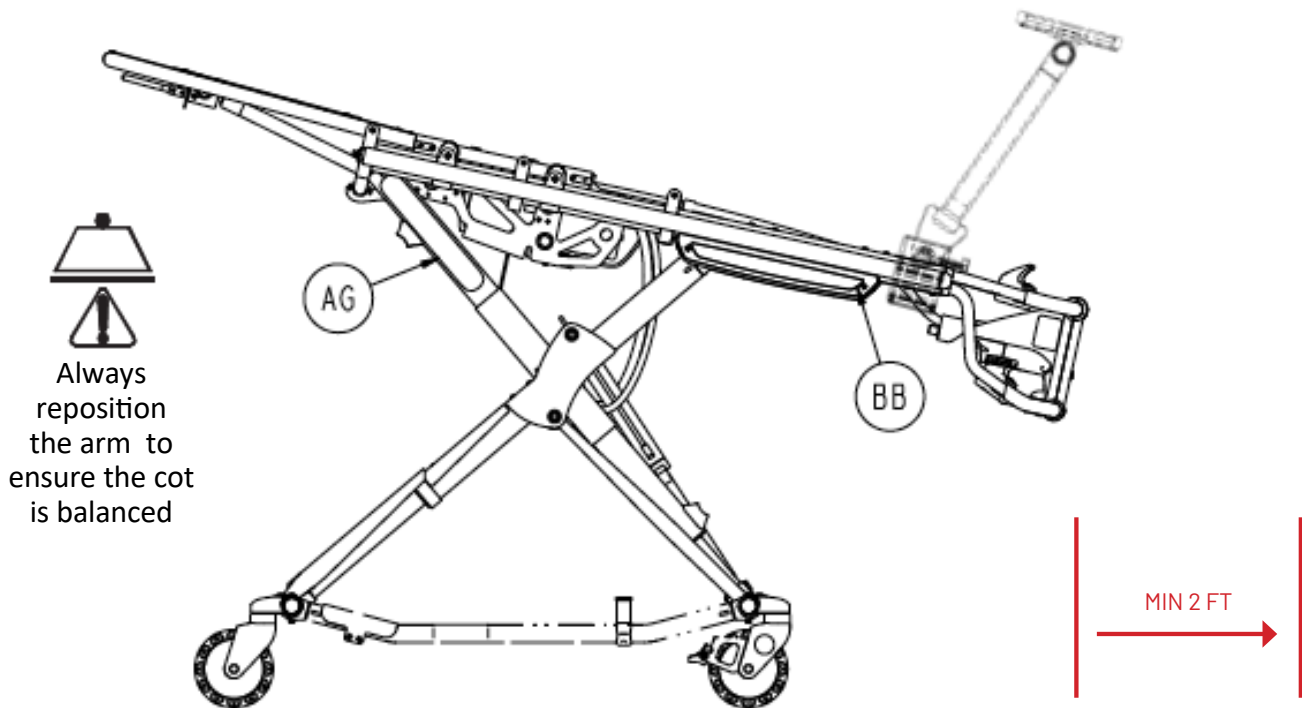

FIGURE 18. PATIENT COT/STRETCHER WITH SAFETY ARM SYSTEM INSTALLED

WARNING

- ✓ Improper usage of the Safety Arm System can cause injury to the patient or operator. Operate the product only as described in this user guide.
- ✓ Do not allow untrained staff to assist in the operation of the arm. Untrained technicians/staff can cause injury to the patient or themselves.
- ✓ Always hold the arm securely when you manipulate it not to drop the safety arm. Dropping the arm could cause injury to the operator or patient.
- ✓ Always pull and hold the locking safety pin (red handle) until it reaches the final position (up (locked) or down (unlocked)) so the arm doesn't fall during transport. Failing to do so can cause injury to the operator or patient.

[Return To Table of Contents](#)

GENERAL OPERATING GUIDELINES

- ✓ Use the Safety Arm System only as described in this user guide.
- ✓ Read all the labels and instructions on the product before using the Safety Arm System.
- ✓ Always inspect the clamp block and arm area for cracks and/or damage before every use.
- ✓ Loading or unloading the Safety Arm System requires a minimum of one (1) trained operator, however, two (2) trained operators are recommended when possible.
- ✓ Do not adjust, or change the arm position while moving with the cot/stretcher.
- ✓ Stay with the patient and control the arm at all times.
- ✓ The arm can be placed into two (2) positions: Locked (Upper position) & Unlocked (Lower position).
- ✓ It is recommended that operators use the system in the upper or locked position while the cot/stretcher is mobile or while the vehicle is moving.
- ✓ Always verify the fixed lock pin is secure prior and during use of the Safety Arm System.
- ✓ Always verify if the side safety pin is firmly pushed and locked into position inside the clamp block during use.



RECOMMENDED LIFTING TECHNIQUES

When lifting the arm, there are six basic guidelines to help you avoid injury:

1. Keep your hands clear from pinch points
2. Keep your back straight
3. Coordinate your movements with your partner on positioning the arm
4. Avoid twisting
5. Always operate the arm as described in this user guide
6. Always secure the movement of the equipment by holding the arm firmly



GENERAL OPERATING GUIDELINES (CONTINUED)

WARNING

- ✓ Never let a patient grab, manipulate or hold the Standard Surface Base or the arm on the cot/stretcher or it may cause injury to the operator or patient. Secure the arm as recommended while the patient is on the cot/stretcher.
- ✓ Always transport the patient while the arm is in the upper or locked position.
- ✓ Lower to the unlocked position when loading and unloading the patient.
- ✓ The upper or locked position maintains the balance of the cot/stretcher and reduces the potential of a cot/stretcher tipping.
- ✓ It is extremely important to raise the safety arm up along the same axis, to its maximum position, even with the weight of the medical device, in order to not damage the tip of the triangle head. Improper positioning of the arm can cause premature damage or cause improper functioning of the system.

RECOMMENDED HANDLING POSITIONS

- ✓ Hold the arm's tubular frame at the center or close to the top near the base.
- ✓ Avoid placing your hands too close to the clamp block base due to pinch points that may cause injury to the operator.
- ✓ To raise the arm in locked position, release the fixed lock pin and pull the arm up.

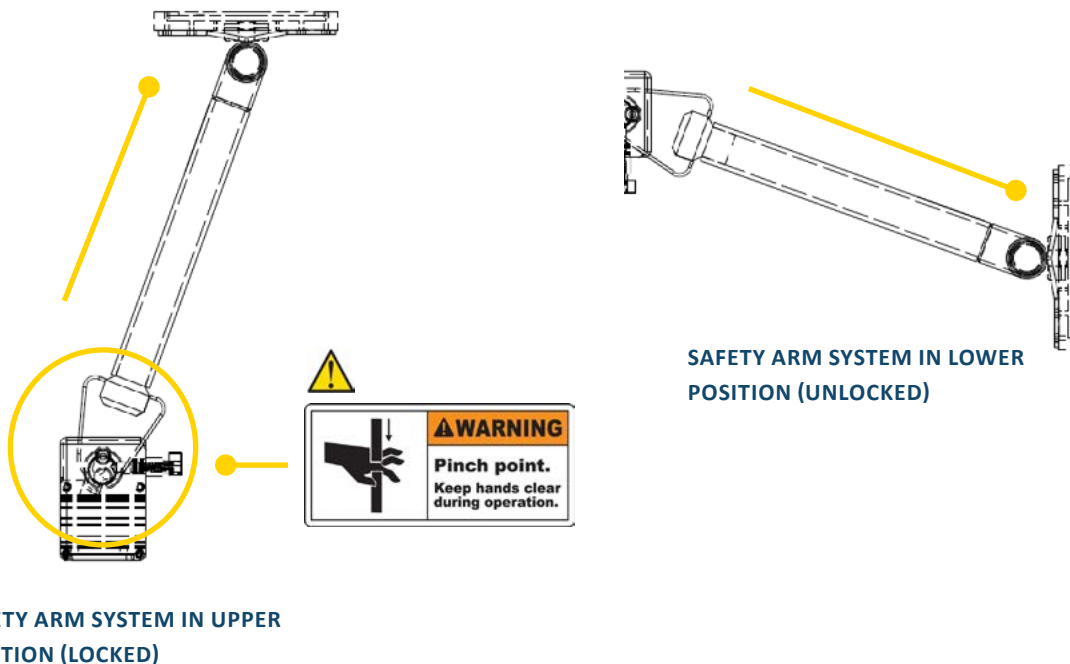

WARNING

- ✓ It is extremely important to raise the safety arm up along the same axis, to its maximum position, even with the weight of the medical device, not to damage the tip of the triangle head. Improper positioning of the arm can cause premature damage or cause improper functioning of the Safety Arm System.

[Return To Table of Contents](#)

OPERATION GUIDE

RECOMMENDED HANDLING POSITIONS (CONTINUED)

NOTE

- ✓ The tip of the triangle head is used to stop the arm from movement (i.e. in case of a rear-end collision) and to secure the arm at a fixed point and engage the fixed locking mechanism.



MAXIMUM UPPER POSITION

OPERATING THE SAFETY ARM SYSTEM

WARNING

- ✓ Two (2) trained operators should be present when repositioning the arm while the cot/stretchers is occupied.
- ✓ Operators must be able to safely lift the total weight of the system including the arm, the medical device and any other item related to the system.
- ✓ Ensure proper hand placement on the tubular pole or surface plate. Hands should be clear of the black clamp block and arm pivot points while loading and unloading the medical equipment or whenever changing height of the arm with two or more operators.

[Return To Table of Contents](#)

OPERATING THE SAFETY ARM SYSTEM (CONTINUED)

LOWERING THE SAFETY ARM

1. Pull and hold the fixed safety pin (red round handle) in order to disengage the triangle head from the clamp block base.

WARNING

Do not put hands near the surface of the triangle head or near the pin inside the opening, during manipulation. Potential pinch point.



2. While keeping the safety pin extended to its fullest extent, lift the arm upwards in the same axis as the arm to reduce friction or resistance when lifting.

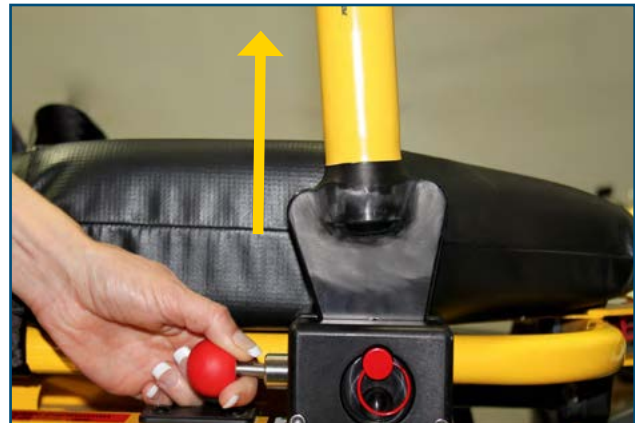

3. Lower the arm until it is in the horizontal position, parallel with the cot/stretchers frame.
4. Release the fixed safety pin.



WARNING

- ✓ Always remove or check if the device is correctly secured into the Standard Surface Base, if lowering the unit.
- ✓ Always hold the arm securely when you manipulate it.
- ✓ Always pull and hold the safety pin (red handle) until it reaches the final upper position (locked) or down (unlocked). Failure to pull the fixed safety pin (red handle) when repositioning the arm may cause damage to the Arm or locking mechanism.

[Return To Table of Contents](#)

OPERATING THE SAFETY ARM SYSTEM (CONTINUED)

RAISING THE SAFETY ARM

1. Pull and hold the fixed safety pin (red round handle) until it reaches the final position.



2. While holding the safety pin, pull the safety arm up.



3. Bring the safety arm all the way up into vertical position and make sure the triangle head is correctly seated into the clamp block.
4. Release the safety pin to lock the Safety Arm in its vertical position for transport.



WARNING

- ✓ Always use the system with the lock pin (pin with finger ring) in the system.
- ✓ Always hold the arm securely when you manipulate it.
- ✓ Always pull and hold the safety pin (red handle) until it reaches the final upper position (locked) or down (unlocked). Failure to pull the safety pin (red handle) when repositioning the arm may cause damage to the Arm or locking mechanism.

[Return To Table of Contents](#)

OPERATING THE SAFETY ARM SYSTEM (CONTINUED)

REMOVING THE SAFETY ARM

1. Put the Safety Arm in vertical position.
2. Remove the medical device from the Standard Surface Base on the Safety Arm System.

WARNING

Ensure that the medical device has been removed from the Standard Surface Base prior to removing the Safety Arm from the clamp block. Failure to do so, can cause injury to the patient or operator and damage to the equipment and medical device.



3. Remove the fixed lock pin by pulling outwards.



4. Pull and hold the Safety Pin (red round handle).



OPERATING THE SAFETY ARM SYSTEM (CONTINUED)

REMOVING THE SAFETY ARM (CONTINUED)

5. While Securely holding the arm, pull upward in order to disengage the triangle head from the clamp block.



6. Once the Safety Arm is removed, put the lock pin back into the clamp block.



SAFETY ARM SYSTEM OPTIONS

STRYKER POWER-PRO OPTIONS

Some exceptions may apply for the Power-PRO stretcher. Please confirm with Customer Service at customerservice@technimount.com prior to placing your order.

DESCRIPTION	OPTION PART NUMBER
Tubular Arm with Triangular Base – Patient Right Installation Yellow-Powder-Coated Finish	400-20-UN
Tubular Arm with Triangular Base – Patient Left Installation Yellow-Powder-Coated Finish	400-20-UN-LFS
Angled Arm with Triangular Base – Patient Right Installation Yellow-Powder-Coated Finish	400-20-UN-ANG
Angled Arm with Triangular Base – Patient Left Installation Yellow-Powder-Coated Finish	400-20-UN-LFS-ANG
Clamp Block – Stryker Cot/Stretcher - Patient Left Installation	500-10-PFXT-LFS
IV Pro Adapter – IV Pole Support – Patient Left Installation - Without Knee Gatch	511-00-UN-LFS - WHKG
IV Pro Adapter – IV Pole Support – Patient Left Installation - With Knee Gatch	511-00-UN-LFS - KG
IV Pro Adapter – IV Pole Support – Patient Right Installation - Without Knee Gatch	511-00-UN-RHS - WHKG
IV Pro Adapter – IV Pole Support – Patient Right Installation –With Knee Gatch	511-00-UN-RHS - KG

STRYKER MX-PRO OPTIONS

DESCRIPTION	OPTION PART NUMBER
Clamp block for the Stryker MX-PRO Cot/Stretcher – Patient Right Installation	530-10-MXPR
Clamp block for the Stryker MX-PRO Cot/Stretcher – Patient Left Installation	530-10-MXPR-LFS
IV Pro Adapter for the Stryker MX-PRO Cot/Stretcher – Patient Right Installation	511-00-MXP-RHS
IV Pro Adapter for the Stryker/ MX-PRO Cot/Stretcher – Patient Left Installation	511-00-MXP-LFS



WARNING

Do not modify the arm or any components of the system. Modifying the product can cause unpredictable operation resulting in injury to the patient or operator.

[Return To Table of Contents](#)

CLEANING THE SAFETY ARM SYSTEM

CLEANING PROCESS

The Safety Arm System can be cleaned by using a pressure washer. The unit may show some signs of oxidation or discoloration from continuous washing, however, degradation of the cot/stretchers performance or functionality will not be affected due to power washing if cleaning instructions are properly followed.

The material used to manufacture the Safety Arm System is 6061-T6 Aluminum, it is very durable and resistant to corrosion, however high levels of sodium or a high concentration of sodium or acid may prematurely corrode the product. Always rinse with soft soap and water if exposed.

- ✓ Use of a power washer can accelerate removal of contaminants collected during the use of the product.
- ✓ Rinse with clean water.
- ✓ Towel dry all casters and interface points, inside the triangle head and clamp block.
- ✓ Allow all other components to air dry.
- ✓ Avoid over saturation and ensure that the product does not stay wet longer than the cleaner manufacturer's guidelines for proper disinfecting.



WARNING

- ✓ When cleaning, always use appropriate personal protection equipment (PPE) based on established protocols (e.g., gloves, eye wear, etc.).



CAUTION

- ✓ Do not steam clean or use ultrasonic cleaners on the system or any of its components.
- ✓ Do not immerse the metal parts/components in water.
- ✓ Maximum water temperature should not exceed 180°F/82°C
- ✓ Maximum water pressure should not exceed 1500 psi/103.5 BAR . If a pressure washer is being used to clean the unit, the pressure nozzle must be kept a minimum of 24 inches (61 cm) from the unit.

CLEANING SOLUTIONS

Phenolic type or quaternary type disinfectants can be used (excluding Virex® TB). Iodophor type disinfectants, Peracetic Acid, Chlorine, and especially Peroxide Oxygen are not recommended for use because staining and corrosion may result.

Suggested cleaners for the Safety Arm System surfaces and clamp box:

- ✓ Quaternary Cleaners (active ingredient - ammonium chloride)
- ✓ Phenolic Cleaners (active ingredient - o-phenyl phenol)
- ✓ Chlorinated Bleach Solution (3.25% - less than 1-part bleach to 100 parts water)

CLEANING THE SAFETY ARM SYSTEM (CONTINUED)

CLEANING SOLUTIONS CONTINUED

WARNING

- ✓ Some cleaning products are corrosive in nature and may cause damage to the product if used improperly.
- ✓ If the products described above are used to clean the equipment, the Safety Arm System must be rinsed with clean water and thoroughly dried following cleaning. Failure to properly rinse and dry the Safety Arm will leave a corrosive residue on the surface of the product, possibly causing premature corrosion of critical components.

REMOVAL OF IODINE COMPOUNDS

Use a solution of 1/4 Tablespoon of Sodium Thiosulfate in 1 pint / .5 litre of warm water to clean the stained area. Clean as soon as possible after staining occurs. If stains are not immediately removed, allow solution to soak or stand on the surface. Thoroughly rinse surfaces with clean water and allow to air dry before returning unit to service.

WARNING

- ✓ Failure to properly clean contaminated parts or components will increase the risk of exposure to blood borne pathogens and may cause injury to the patient or the operator.

PREVENTIVE MAINTENANCE

A preventive and regular maintenance program should be established for all Technimount equipment. Preventive maintenance may be required more frequently based on the usage level of the product. The Safety Arm System requires regular preventive maintenance. Establish and follow a preventive maintenance schedule and keep records of preventive maintenance activities (see maintenance form).

CAUTION

- ✓ Close attention should be given to safety features including, but not limited to the clamp block, tubular arm, surface plate, and standard surface base mount.
- ✓ Improper maintenance can cause injury or damage to the product. Maintain the product as described in this user guide.

LUBRICATION

The Safety Arm System has been designed to operate without the need for lubrication. Due to an anodization of the metallic parts, using a silicone-base lubricant can be used but it is not necessary. If you're not sure about the product to use, please contact technical support or customer service.

CAUTION

- ✓ Failure to use authorized parts, lubricants, etc. could cause damage to the cot/stretchers and will void the warranty of the product.

[Return To Table of Contents](#)

MAINTENANCE GUIDE

INSPECTION PROCESS AND SCHEDULE

PREVENTIVE MAINTENANCE PROGRAM

The following inspection routine and schedule is intended as a general guide for preventive maintenance of the Safety Arm System. Factors such as weather, environment, geographical location, and individual usage will necessitate different maintenance. If you are unsure as to how to perform these maintenance inspections or at what interval to perform these inspections, please contact your Technical Support Team at techsupport@technimount.com. Check each routine and replace damaged or worn out parts if necessary.

Follow timetable below for maintenance (either in months (M) or hours (H)), in accordance with your Services' current maintenance practices and protocols.

ITEM	ROUTINE	<u>1 M</u> <u>OR</u> <u>2 H</u>	<u>3 M</u> <u>OR</u> <u>6 H</u>	<u>6 M</u> <u>OR</u> <u>12 H</u>	<u>12 M</u> <u>OR</u> <u>24 H</u>
Clamp Block	<ul style="list-style-type: none"> ✓ Inspect the 4 hexagon screws of the clamp block <ul style="list-style-type: none"> ▪ If loose, or unscrewed, tighten screw ▪ If broken, the screw must be replaced ✓ Inspect and tighten the 2 bolts under the clamp block that hold the system on the cot/stretchers frame ✓ Check fixed safety lock <ul style="list-style-type: none"> ▪ Ensure it is working properly and there are no particles, obstacles, or debris ✓ Check side safety lock pin <ul style="list-style-type: none"> ▪ Must be locked properly ✓ Verify if the frame of the cot/stretchers is not cracked or broken around the area of the clamp block 	X			
Arm - Tubular Pole	<ul style="list-style-type: none"> ✓ Verify all welds are intact, not cracked or broken ✓ Verify not that the Arm is not bent, broken, or has damaged components ✓ Verify that the retaining post is secure ✓ Verify that there is no excessive damage to Arm ✓ Verify the Arm operates properly 		X		
Surface Plate	<ul style="list-style-type: none"> ✓ Inspect the 4 bolts and nuts to secure the surface base onto the surface plate 	X			

[Return To Table of Contents](#)

MAINTENANCE GUIDE

INSPECTION AND MAINTENANCE RECORD

<u>PREVENTIVE MAINTENANCE PERFORMED</u>	<u>BY</u>	<u>DATE</u>	<u>TIME</u>

[Return To Table of Contents](#)

MAINTENANCE GUIDE

TRAINING RECORD

<u>TRAINEE NAME</u>	<u>TRAINING DATE</u>		<u>TRAINING METHOD</u> <u>USER GUIDE,</u> <u>IN-SERVICE,</u> <u>IN-CLASS,</u> <u>ETC.</u>
	<u>BASIC</u> <u>TRAINING</u>	<u>TRAINING</u> <u>UPDATE</u>	

REPLACEMENT PARTS

The parts and accessories listed are all currently available for purchase. Some of the parts identified on the assembly drawing parts in this user guide may not be individually available for purchase. Please call Technimount Customer Service at +1.581-998-9820 or at customerservice@technimount.com for availability and pricing.

<u>DESCRIPTION</u>	<u>PART NUMBER</u>
Clamp Block – for the Stryker Cot/Stretcher - Patient Right Installation	500-10-PFXT
Tubular Arm with Triangular Base – Patient Right Installation with Yellow-Powder-Coated Finish	400-20-UN
Stainless Steel Lock Pin - Without Color	910-00-UN
Stainless Steel Lock Pin - Red-Anodized Finish	910-00-PTR
Fixed Safety Pin with Red Handle (Kit with 3 parts)	920-00-UN
Label – Brand Name	940-00-UN
Label – Instructions in English	930-00-EN
Label – Instructions in French	930-00-FR

WARRANTY POLICY

This statement constitutes TECHNIMOUNT's entire warranty policy with regards to the TECHNIMOUNT Products.

TECHNIMOUNT MAKES NO OTHER WARRANTY OR REPRESENTATION NEITHER EXPRESSED NOR IMPLIED, EXCEPT AS SET FORTH HEREIN. THERE IS NO WARRANTY OF MERCHANTABILITY AND THERE ARE NO WARRANTIES OF FITNESS FOR ANY PARTICULAR PURPOSE. IN NO EVENT SHALL TECHNIMOUNT BE LIABLE HEREUNDER FOR INCIDENTAL OR CONSEQUENTIAL DAMAGES ARISING FROM OR IN ANY MANNER RELATED TO SALES OR USE OF ANY SUCH EQUIPMENT.

TECHNIMOUNT E.M.S. Holding Inc. (TECHNIMOUNT) guarantees to the original "Purchaser" of the "Hardware" with which this "Limited Warranty" is included that the Hardware will be free from "Defects" in workmanship and materials under normal use for a "Warranty Period", one (1) year from the date that the Hardware was first purchased by the Purchaser. During the Warranty Period, the Hardware will be repaired or replaced according to the "Limited Warranty" without charge to the Purchaser for either parts or labor. The parts may be repaired or replaced with either new or refurbished parts. The product may be replaced for a new or refurbished product. For this Limited Warranty "refurbished" means parts and products, which have been returned to factory specifications. If the Hardware is repaired or replaced within the Warranty Period, the greater of the remaining warranty period will apply or three (3) months from the date of repair/replacement. If the Hardware is repaired or replaced after the Warranty Period has expired, the Warranty Period for the repair or replacement will expire three (3) months after the date of repair or replacement.

LIMITED RESPONSIBILITY AND WARRANTY

The Limited Warranty does not apply to normal wear that should result from normal use. It does not apply when the Hardware or any component is opened, disassembled, or repaired by someone not authorized by TECHNIMOUNT and does not cover repair or replacement of any Hardware or part thereof damaged by neglect, misuse, moisture, liquids, exposure to heat, accidents, abuse, and non-compliance with the instructions for installation and use provided with the Hardware. The Limited Warranty does not cover physical damage to the surface of the Hardware, and the decision to repair, replace or refuse the coverage is final and its sole discretion of TECHNIMOUNT, and is made without any compensation or obligation from TECHNIMOUNT.

The hardware, or product defined as a mounting or bracket system for clipping and attaching medical equipment is specifically designed to fill this requirement. Any other use will void the warranty and TECHNIMOUNT will not be held liable on any claim if the product is modified or adapted for use.

Technimount products are intended to retain a medical device in place in the case of a single crash impact. A Technimount product must NOT be used again if it was involved in a crash. The product MUST be replaced. If the Purchaser uses a Technimount product following a crash, it is at the Purchaser's own risk and Technimount will not be held liable.

INTERNATIONAL WARRANTY CLAUSE

This warranty reflects Canadian domestic policy. Warranty outside Canada may vary by country. Please contact TECHNIMOUNT Customer Service for more information.

RETURN POLICY

RETURN POLICY

Mounting systems and bracket systems for portable medical devices may be returned up to 60 days of receipt if:

- The product is not what was originally ordered
- The product does not meet specifications with TECHNIMOUNT's technical sheets according to the customer
- The product is not compatible with the equipment on which it was to be installed

For any manufacturing defect, refer to the conditions of the Warranty Policy.

PRIOR TO 30 DAYS

- Product must be undamaged and in its original packaging
- The product return request must be provided in writing and it must be approved by TECHNIMOUNT prior to returning the product
- Returns will not be approved on a modified or damaged item
- Charges may apply if damaged or missing item
- Customer is responsible for a 10% restocking fee

PRIOR TO 45 DAYS

- Product must be unused, undamaged and in its original packaging
- The product return request must be provided in writing and it must be approved by TECHNIMOUNT prior to returning the product
- Returns will not be approved on modified or damaged item
- Charges may apply if damaged or missing items
- Customer is responsible for a 25% restocking fee

PRIOR TO 60 DAYS

- Product must be unused, undamaged and in its original packaging
- The product return request must be provided in writing and it must be approved by TECHNIMOUNT prior to returning the product
- Returns will not be approved on a modified or damaged item
- Charges may apply if damaged or missing items
- Customer is responsible for a 30% restocking fee

RETURN AUTHORIZATION

TECHNIMOUNT's customer service department is responsible for approving any merchandise return and will provide a Return Merchandise Authorization (RMA) number to be printed on any returned merchandise. TECHNIMOUNT reserves the right to charge shipping and restocking fees on returned items. SPECIAL, MODIFIED, OR DISCONTINUED ITEMS NOT SUBJECT TO RETURN.

[Return To Table of Contents](#)

RETURN POLICY

DAMAGED MERCHANDISE

ICC Regulations require that claims for damaged merchandise must be made with the carrier within fifteen (15) days of receiving merchandise. DO NOT ACCEPT DAMAGED SHIPMENTS UNLESS SUCH DAMAGE IS NOTED ON THE DELIVERY RECEIPT AT THE TIME OF RECEIPT. Upon prompt notification, TECHNIMOUNT will file a freight claim with the appropriate carrier for damages incurred. Claim will be limited in amount to the actual replacement cost. In the event that this information is not received by TECHNIMOUNT within the fifteen (15) day period following the delivery of the merchandise, or the damage was not noted on the delivery receipt at the time of receipt, the customer will be responsible for payment of the original invoice in full.

Note: Claims for any short or broken shipment must be made within thirty (30) days of invoice.

CLAIM PROCESS

Please follow the claim procedure below to return a defective product:

Contact our Customer Service at + 1 581-700-6613 or at customerservice@technimount.com.

Fill in the RMA form online at <https://www.technimount.com/service-support/service-support-overview/>

REQUIRED INFORMATION

- Serial number
- Invoice number
- Identification of the issue
- Upload the pictures of the issue
- Submit the form

A confirmation of the receipt of the claim will be sent to you within 2 business days. If you have not received a confirmation Email by then, please contact techsupport@technimount.com.

TECHNIMOUNT's customer service department is responsible for approving any merchandise return and will provide a Return Merchandise Authorization (RMA) number to be printed on any returned merchandise. TECHNIMOUNT reserves the right to charge shipping and restocking fees on returned items. SPECIAL, MODIFIED, OR DISCONTINUED ITEMS NOT SUBJECT TO RETURN.

FINDINGS AND CONCLUSION

- If following an investigation, we find that our product is defective, TECHNIMOUNT will take corrective actions and close the claim
- If following an investigation, we find that our product is NOT defective (misuse or abuse of the product) the product will not be covered by the warranty. Details of our findings and conclusions will be provided to you.

QUESTIONS ABOUT OUR POLICY

If you have any questions regarding our return policy, please contact our Customer Service department at customerservice@technimount.com.

[Return To Table of Contents](#)



SAFETY AND FLEXIBILITY WHERE IT MATTERS MOST

TECHNIMOUNT E.M.S. HOLDING INC.
3770 Jean-Marchand Street, Suite 100-C
Quebec (QC) G2C 1Y6
Canada
T+ 1 581.700.6613
TF + 1 888.639.2758
technimount.com
info@technimount.com

© 2022 Technimount E.M.S. Holding Inc. - All Rights Reserved
Printed in Canada



SAS UG 202205-01



TECHNIMOUNT
EMS™

SAFETY ARM SYSTEM™

USER GUIDE

